MODULE 2: PUMPS AND ACTUATORS

Pumps: Classification of pumps, pumping theory of positive displacement pumps, construction and working of Gear pumps, Vane pumps, Piston pumps, fixed and variable displacement pumps, Pump performance characteristics, pump selection factors, problems on pumps.

Accumulators: Types, selection/ design procedure, applications of accumulators. Types of Intensifiers, Pressure switches /sensor, Temperature switches/sensor, Level sensor.

Actuators: Classification cylinder and hydraulic motors, Hydraulic cylinders, single and double acting cylinder, mounting arrangements, cushioning, special types of cylinders, problems on cylinders. Construction and working of rotary actuators such as gear, vane, piston motors, and Hydraulic Motor. Theoretical torque, power, flow rate, and hydraulic motor performance; numerical problems. Symbolic representation of hydraulic actuators (cylinders and motors).

PUMPS

A pump, which is the heart of hydraulic system, converts mechanical energy into hydraulic energy. The mechanical energy is delivered to the pump using a prime mover such as an electric motor. Due to the mechanical action, the pump creates a partial vacuum at its inlet. This permits atmospheric pressure to force the fluid through the inlet line and into the pump. The pump then pushes the fluid into the hydraulic system.

CLASSIFICATION OF PUMPS:

Pumps are broadly classified into two types

- 1) Dynamic (non-positive displacement) pumps
- 2) Positive displacement pumps

1) Dynamic (non-positive displacement) pumps: This type is generally used for low-pressure, high-volume flow applications. Because they are not capable of withstanding high pressures, they are of little use in the fluid power field. Normally their maximum pressure capacity is limited to 250-300psi. This type of pump is primarily used for transporting fluids from one location to another. The two most common types of dynamic pumps are the centrifugal and axial flow propeller pumps.

2) Positive displacement pumps: This type is universally used for fluid power systems. As the name implies, a positive displacement pump ejects a fixed amount of fluid into the hydraulic system per revolution of pump shaft rotation. Such a pump is capable of overcoming the pressure resulting from the mechanical loads on the system as well as the resistance to flow due to friction.

Positive displacement pumps are further classified into:

i) Fixed displacement pumps: It is the one in which the amount of fluid ejected per revolution (displacement) cannot be varied.

ii) Variable displacement pumps: In this type of pumps, the displacement can be varied by changing the physical relationships of various pump elements. This change in pump displacement produces a change in pump flow output even though pump speed remains constant.

The advantages of positive displacement pumps over non-positive displacement pumps are as follows:

1. They can operate at very high pressures of up to 800 bar (used for lifting oils from very deep oil wells).
2. They can achieve a high volumetric efficiency of up to 98%.
3. They are highly efficient and almost constant throughout the designed pressure range.
4. They are a compact unit, having a high power-to-weight ratio.
5. They can obtain a smooth and precisely controlled motion.
6. By proper application and control, they produce only the amount of flow required to move the load at the desired velocity.
7. They have a great flexibility of performance. They can be made to operate over a wide range of pressures and speeds.

PUMPING THEORY OF POSITIVE DISPLACEMENT PUMPS:

Pumps operate on the principle whereby a partial vacuum is created at the pump inlet due to the internal operation of the pump. This allows atmospheric pressure to push the fluid out of oil tank (reservoir) and into the pump intake. The pump then mechanically pushes the fluid out the discharge line. This action can be best described by reference to a simple piston pump shown in Fig.

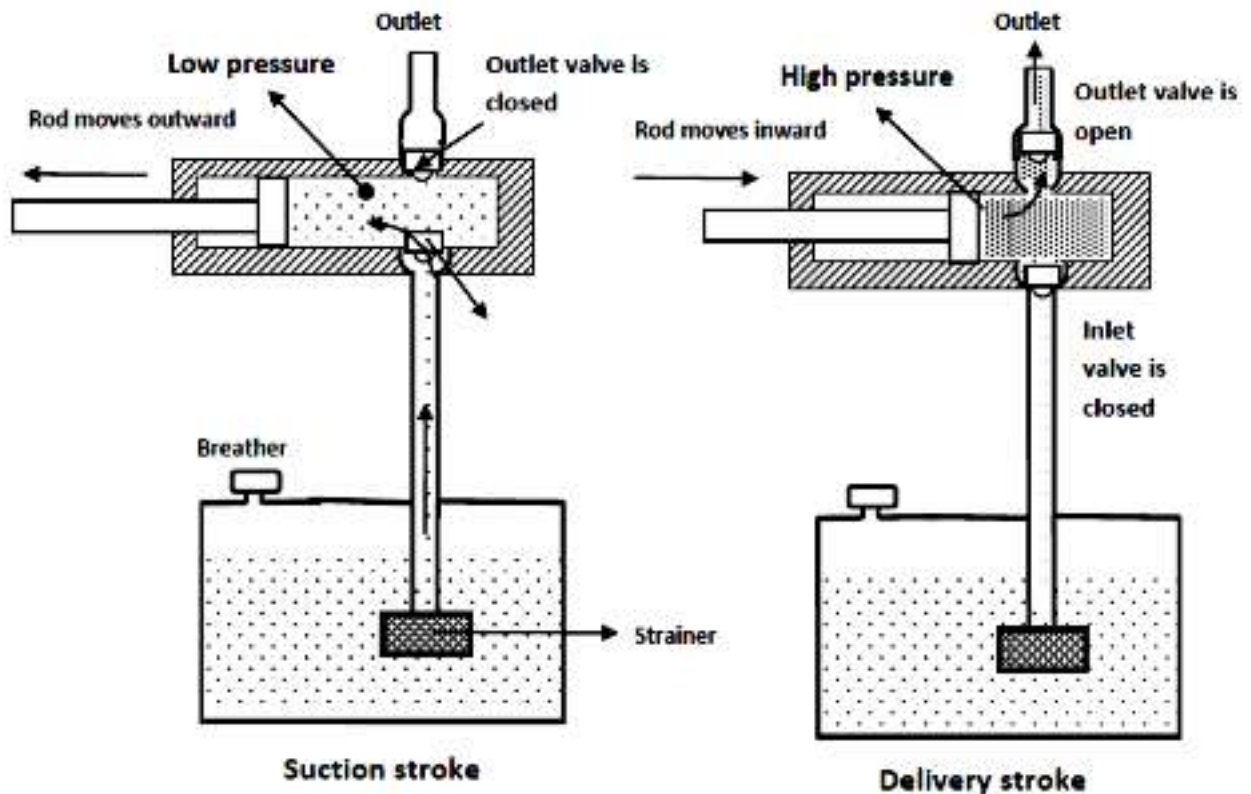

1. As the piston moves to the left, a partial vacuum is created in the pump chamber that holds the outlet valve in place against its seat and induces flow from the reservoir that is at a higher (atmospheric) pressure. As this flow is produced, the inlet valve is temporarily displaced by the force of fluid, permitting the flow into the pump chamber (suction stroke).

2. When the piston moves to the right, the resistance at the valves causes an immediate increase in the pressure that forces the inlet valve against its seat and opens the outlet valve thereby permitting the fluid to flow into the system. If the outlet port opens directly to the atmosphere, the only pressure developed is the one required to open the outlet valve (delivery stroke).

CLASSIFICATION OF POSITIVE DISPLACEMENT PUMPS:**1. Gear Pumps**

- External Gear pump
- Internal Gear pump

2. Vane Pumps

- Balanced vane pump
- Unbalanced vane pump

3. Piston Pumps

- Axial type
- Radial type

GEAR PUMPS:

Gear pumps are less expensive but limited to low pressures. It is noisy in operation than either vane or piston pumps. Gear pumps are invariably of fixed displacement type, which means that the amount of fluid displaced for each revolution of the drive shaft is theoretically constant.

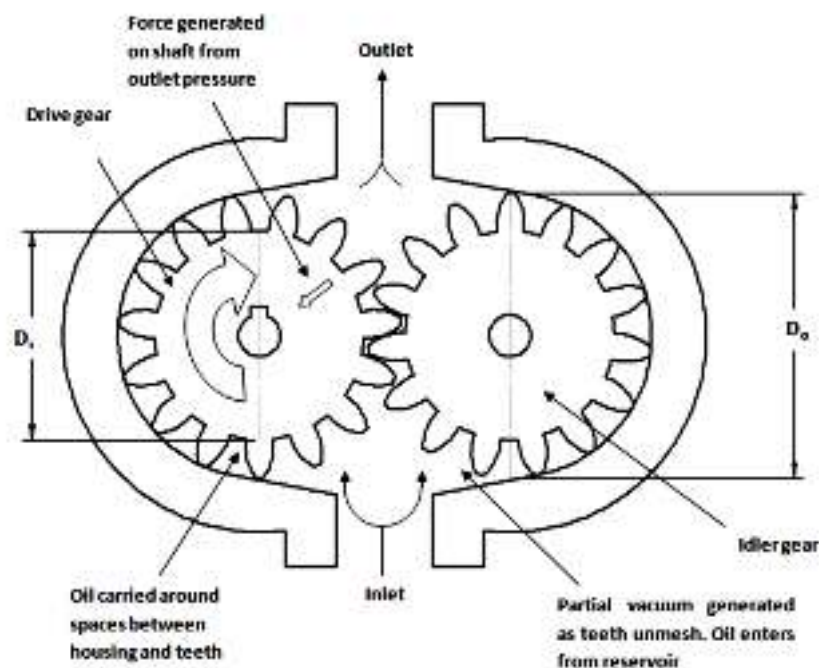
EXTERNAL GEAR PUMPS:

External gear pumps are the most popular hydraulic pumps in low-pressure ranges due to their long operating life, high efficiency and low cost. They are generally used in a simple machine. The external gear pump consists of a pump housing in which a pair of precisely machined meshing gears runs with minimal radial and axial clearance. One of the gears, called a driver, is driven by a prime mover. The driver drives another gear called a follower. As the teeth of the two gears separate, the fluid from the pump inlet gets trapped between the rotating gear cavities and pump housing. The trapped fluid is then carried around the periphery of the pump casing and delivered to outlet port. The teeth of precisely meshed gears provide almost a perfect seal between the pump inlet and the pump outlet.

INTERNAL GEAR PUMPS:

Internal Gear Pumps consist of two gears: An external gear and an internal gear. The crescent placed in between these acts as a seal between the suction and discharge. When a pump operates, the internal gear drives the external gear and both gears rotate in the same direction. The fluid fills the cavities formed by the rotating teeth and the stationary crescent. Both the gears transport the fluid through the pump. The crescent seals the low-pressure pump inlet from the high-pressure pump outlet. These pumps have a higher pressure capability than external gear pumps.

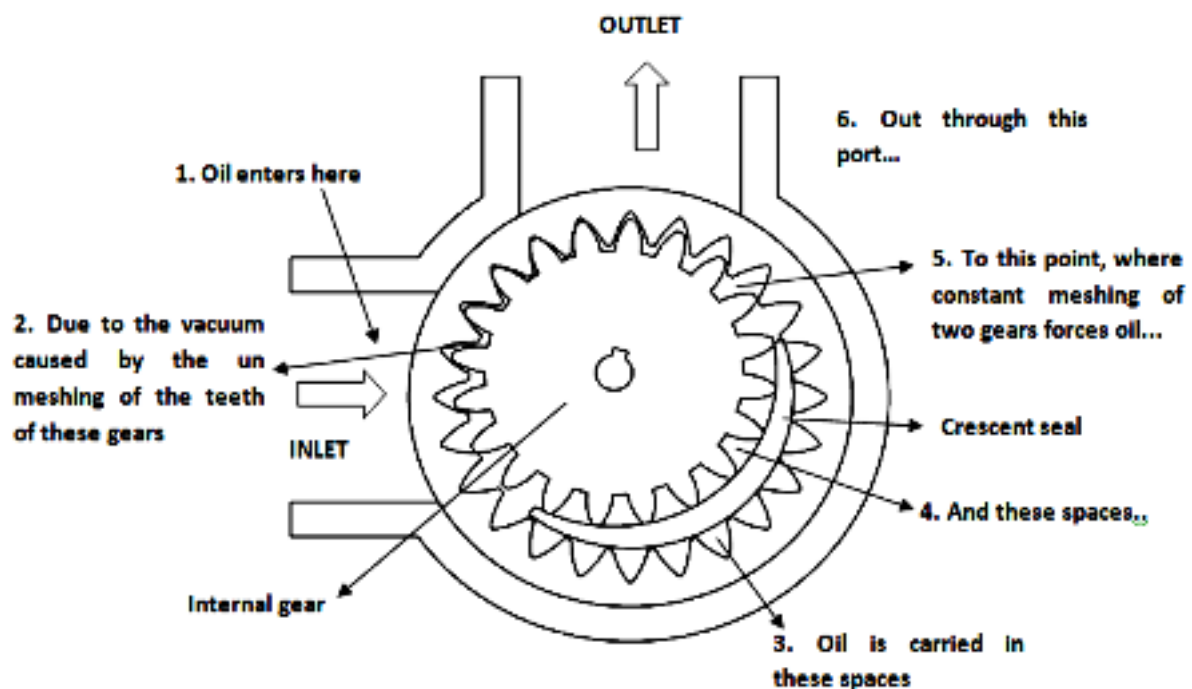

ADVANTAGES OF GEAR PUMPS:

- 1.They are self-priming.
- 2.They give constant delivery for a given speed.
3. They are compact and light in weight.

DISADVANTAGES OF GEAR PUMPS:

1. The liquid to be pumped must be clean, otherwise it will damage pump.
2. Variable speed drives are required to change the delivery.
3. If they run dry, parts can be damaged because the fluid to be pumped is used as lubricant.

VANE PUMPS:

Vane Pumps are classified into

1. Unbalanced vane pump

- Fixed displacement type
- Pressure compensated variable displacement type

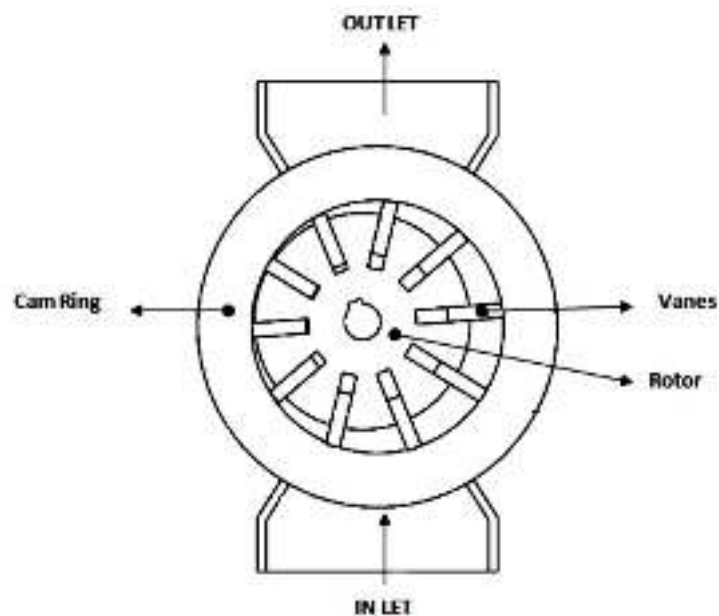
2. Balanced vane pump**UNBALANCED FIXED DISPLACEMENT VANE PUMP:**

The main components of the pump are the cam surface and the rotor. The rotor contains radial slots splined to drive shaft. The rotor rotates inside the cam ring. Each radial slot contains a vane, which is free to slide in or out of the slots due to centrifugal force. The cam ring axis is offset to the drive shaft axis. When the rotor rotates, the centrifugal force pushes the vanes out against the surface of the cam ring. The vanes divide the space between the rotor and the cam ring into a series of small chambers. During the first half of the rotor rotation, the volume of these chambers increases, thereby causing a reduction of pressure. This is the suction process, which causes the fluid to flow through the inlet port. During the second half of rotor rotation, the cam ring pushes the vanes back into the slots and the trapped volume is reduced. This positively ejects the trapped fluid through the outlet port. The delivery rate of the pump depends on the eccentricity of the rotor with respect to the cam ring.

UNBALANCED PRESSURE COMPENSATED VARIABLE DISPLACEMENT VANE PUMP:

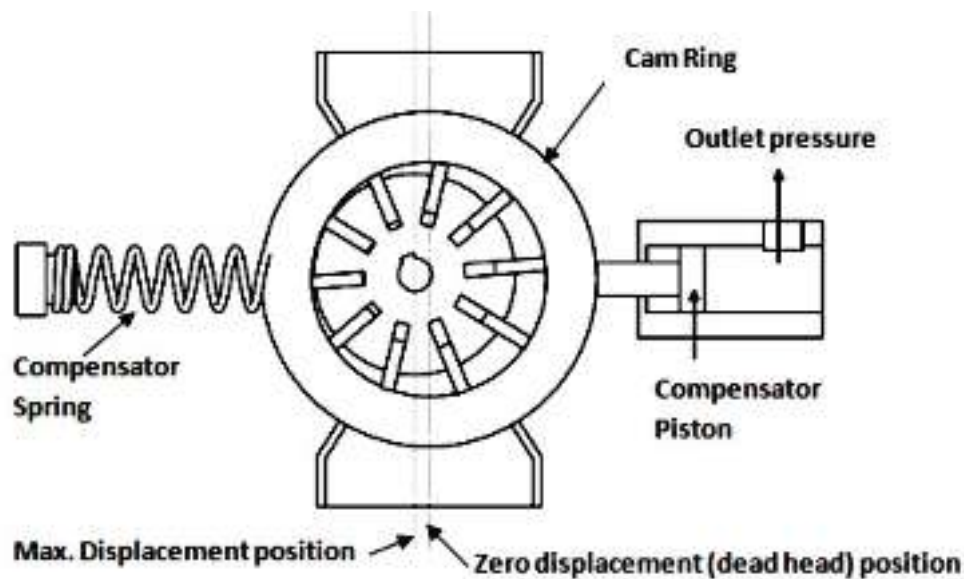

Variable displacement feature can be brought into vane pumps by varying eccentricity between the rotor and the cam ring. Here in this pump, the stator ring is held against a spring loaded piston. The system pressure acts directly through a hydraulic piston on the right side. This forces the cam ring against a spring-loaded piston on the left side. If the discharge pressure is large enough, it overcomes the compensated spring force and shifts the cam ring to the left. This reduces the eccentricity and decreases the flow. If the pressure continues to increase, there is no eccentricity and pump flow becomes zero.

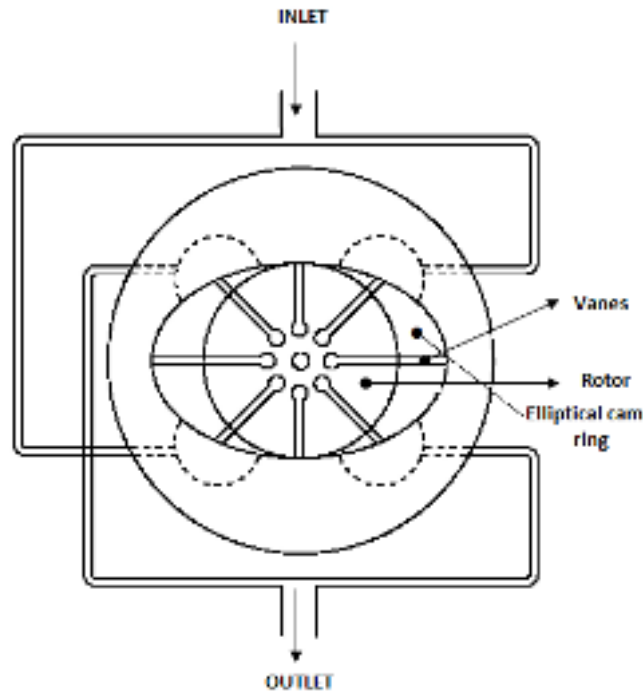
BALANCED VANE PUMP:

The constructional features of a balanced vane pump is as shown in the fig. The rotor and the casing are on the same centre line. Vanes are provided in the slots of the rotor. There are two inlet and outlet chambers around the elliptical cam ring surface. The inlet and outlet chambers are positioned diagonally opposite to each other. The cam ring is elliptical in shape, so that the vanes stroke twice per revolution of the pump shaft. Thus the volume increase and decrease at the inlet and outlet chambers also occur twice per revolution. In fact, the inlet and outlet ports are connected to a common inlet and outlet within the pump housing. In operation, due to the elliptical shape of the cam ring, the oil suction at the inlets and the pumping at the outlets occurs simultaneously. This situation results in equal pressure on the opposite sides of the pump shaft, and the net force acting on bearing will be zero. Thus, it is termed the balanced vane pump.

PISTON PUMPS:

Piston pumps are of following types

1. Axial Piston Pump

- Swash plate type piston pump
- Bent axis type piston pump

2. Radial Piston Pump

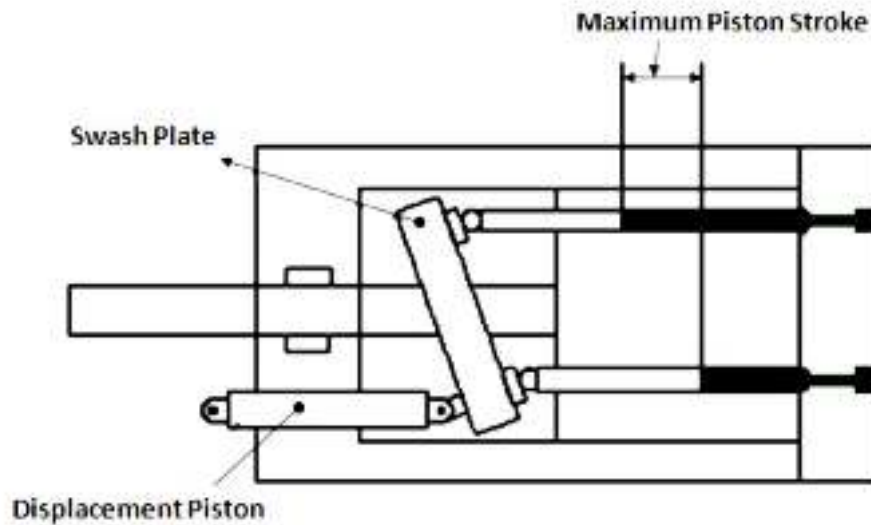
SWASH PLATE TYPE PISTON PUMP:

In this type, the cylinder block and drive shaft are located on the same center line. The pistons are connected to a shoe plate that bears against an angled swash plate. As the cylinder rotates, the pistons reciprocate because the piston shoes follow the angled surface of the swash plate. The outlet and inlet ports are located in the valve plate so that the pistons pass the inlet as they are being pulled out and pass the outlet as they are being forced back in. This type of pump can also be designed to have a variable displacement capability.

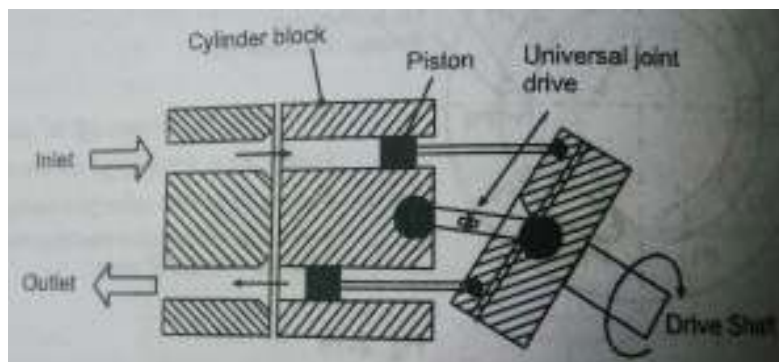
BENT AXIS TYPE PISTON PUMP:

In construction it consists of a cylinder block with arrayed cylindrical openings, housing, pistons and drive shaft. The housing design is such that it creates an offset angle between the centreline of the drive shaft and the centre line of the cylinder block. The pistons are connected to the drive plate with ball and socket joints. The drive plate and the cylinder block

are connected with an universal joint, so that the motion is transmitted through the bent axis. The bent axis of the drive shaft leads to the reciprocatory motion of the pistons in the cylinder block. The housing end at the cylinder block is sealed with an end cap, having inlet and outlet ports with feed grooves.

PUMP PERFORMANCE:

The performance of a pump is a function of the precision of its manufacture. An ideal pump is one having zero clearance between all mating parts. Since this is not possible, working clearances should be as small as possible while maintaining proper oil films for lubrication between rubbing parts. The performance of a pump is determined by the following efficiencies:

- 1) **Volumetric efficiency (η_v):** It is the ratio of actual flow rate of the pump to the theoretical flow rate of the pump.

$$\begin{aligned}\eta_v &= \frac{\text{Actual flow rate}}{\text{Theoretical flow rate}} \times 100 \\ &= \frac{Q_A}{Q_T} \times 100\end{aligned}$$

- 2) **Mechanical Efficiency (η_m):** It refers to the efficiency of the pump due to energy losses other than due to leakages.

$$\begin{aligned}\eta_m &= \frac{\text{Pump output power (no leakage condition)}}{\text{Actual power input to pump}} \times 100 \\ &= \frac{P \times Q_T}{2\pi NT} \times 100\end{aligned}$$

Where, P = Pump discharge pressure, Pa

QT = Theoretical flow rate, m³/s

T = Torque input to pump, N.m

N = Pump speed, rps

- 3) **Overall Efficiency (η_o):** Overall efficiency refers to the overall performance of the pump considering possible losses including the leakage loss, friction loss, etc. it is given by the relation:

$$\eta_o = \frac{\text{Actual power output by pump}}{\text{Actual power input to pump}} \times 100$$

It can also be given by,

$$\eta_o = \frac{\eta_v \times \eta_m}{100}$$
$$\eta_o = \frac{P \times Q_A}{2\pi NT} \times 100$$

PUMP SELECTION FACTORS:

The main parameters affecting the selection of a particular type of pump are as follows:

- 1) Maximum operating pressure.
- 2) Maximum delivery.
- 3) Type of control.
- 4) Pump drive speed.
- 5) Type of fluid.
- 6) Pump contamination tolerance.
- 7) Pump noise.
- 8) Size and weight of a pump.
- 9) Pump efficiency.
- 10) Cost.
- 11) Availability and interchangeability.
- 12) Maintenance and Spares.

ACCUMULATORS:

A hydraulic accumulator is a device that stores the potential energy of an incompressible fluid held under pressure by an external source. The stored potential energy in the accumulator is a quick secondary source of fluid power capable of doing useful work.

CLASSIFICATION OF HYDRAULIC ACCUMULATORS:

- 1) Weight loaded or gravity accumulator
- 2) Spring-loaded accumulator
- 3) Gas-loaded accumulator
 - a) Non-seperator type

- b) Separator type
 - i) Piston type
 - ii) Diaphragm type
 - iii) Bladder type

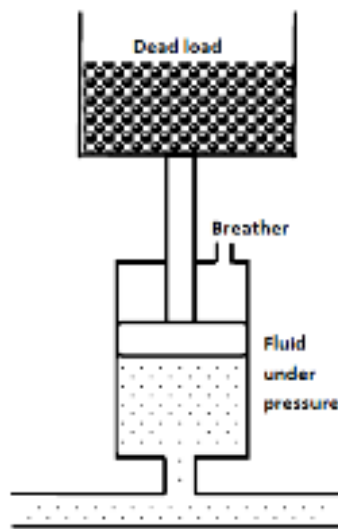
WEIGHT LOADED OR GRAVITY ACCUMULATOR:

It is a vertically mounted cylinder with a large weight. When the hydraulic fluid is pumped into it, the weight is raised. The weight applies a force on the piston that generates a pressure on the fluid side of piston. The advantage of this type of accumulator over other types is that it applies a constant pressure on the fluid throughout its range of motion. The main disadvantage is its extremely large size and heavy weight. This makes it unsuitable for mobile application.

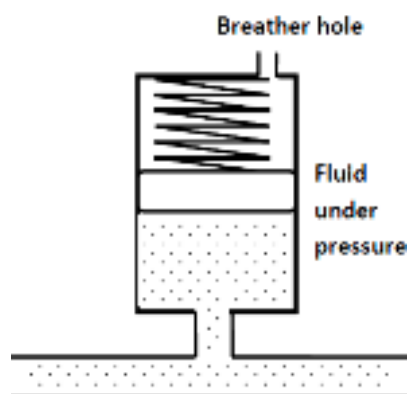
SPRING LOADED ACCUMULATOR:

A spring-loaded accumulator stores energy in the form of a compressed spring. A hydraulic fluid is pumped into the accumulator, causing the piston to move up and compress the spring. The compressed spring then applies a force on the piston that exerts a pressure on the hydraulic fluid. This type of accumulator delivers only a small volume of oil at relatively low pressure.

GAS LOADED ACCUMULATOR:

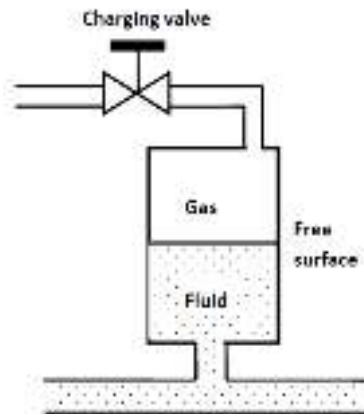

A gas-loaded accumulator is popularly used in industries. Here the force is applied to the oil using compressed air. A gas accumulator can be very large and is often used with water or high water-based fluids using air as a gas charge.

There are two types of gas-loaded accumulators:

- **Non-separator-type accumulator:** Here the oil and gas are not separated. Hence, they are always placed vertically.
- **Separator-type accumulator:** Here the oil and gas are separated by an element. Based on the type of element used to separate the oil and gas, they are classified as follows:
 - a) **Piston type accumulator:** It consists of a cylinder with a freely floating piston with proper seals. Its operation begins by charging the gas chamber with a gas (nitrogen) under a pre-determined pressure. This causes the free sliding piston to move down. Once the accumulator is pre-charged, a hydraulic fluid can be pumped into the hydraulic fluid port. As the fluid enters the accumulator, it causes the piston to slide up, thereby compressing the gas that increases its pressure and this pressure is then applied to the hydraulic fluid through the piston.



- b) **Diaphragm type accumulator:** In this type, the hydraulic fluid and nitrogen gas are separated by a synthetic rubber diaphragm. The advantage of a diaphragm accumulator over a piston accumulator is that it has no sliding surface that requires lubrication and can therefore be used with fluids having poor lubricating qualities. It is less sensitive to contamination due to lack of any close-fitting components.

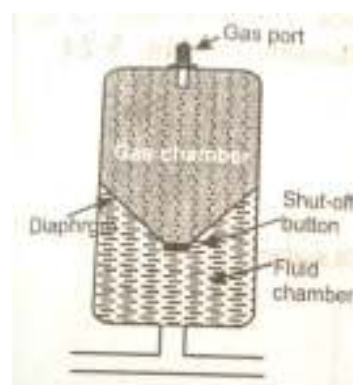

- c) **Bladder type accumulator:** Here the gas and the hydraulic fluid are separated by a synthetic rubber bladder. The bladder is filled with nitrogen until the designed pre-charge pressure is achieved. The hydraulic fluid is then pumped into the accumulator, thereby compressing the gas and increasing the pressure in the accumulator.

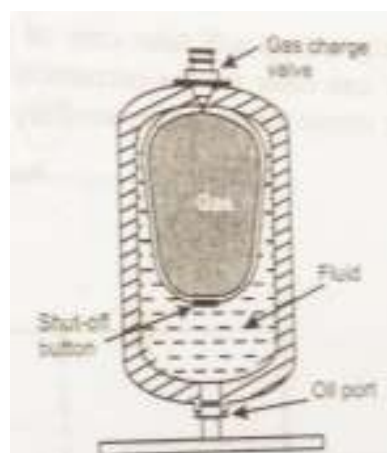

ACTUATORS:

An actuator is used to convert the energy of fluid back into the mechanical power. The amount of output power developed depends upon the flow rate, the pressure drop across the actuator and its overall efficiency. Thus, hydraulic actuators are devices used to convert pressure energy of the fluid into mechanical energy.

Depending on the type of actuation, hydraulic actuators are classified as follows:

- 1) **Linear actuator:** For linear actuation (hydraulic cylinders)
- 2) **Rotary actuator:** For rotary actuation (hydraulic motor)

Hydraulic linear actuators, as their name implies, provide motion in a straight line. They are usually referred to as cylinders, rams and jacks. The function of hydraulic cylinder is to convert hydraulic power into linear mechanical force or motion. Hydraulic cylinders extend and retract a piston rod to provide a push or pull force to drive the external load along a straight-line path.

Hydraulic cylinders are of the following types:

- Single-acting cylinders
- Double-acting cylinders
- Double rod cylinders
- Tandem cylinders
- Telescopic cylinders
- Cushioned cylinders

SINGLE-ACTING CYLINDERS:

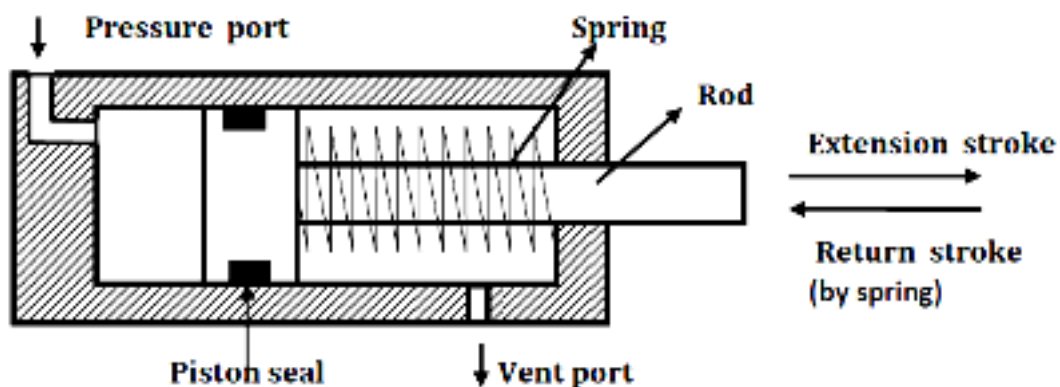

A single-acting cylinder is simplest in design and consists of a piston inside a cylindrical housing called barrel. On one end of the piston there is a rod, which can reciprocate. At the opposite end, there is a port for the entrance and exit of oil. Single-acting cylinders produce

force in one direction by hydraulic pressure acting on the piston during extension stroke. The retraction is done either by gravity or by a spring.

DOUBLE ACTING CYLINDERS:

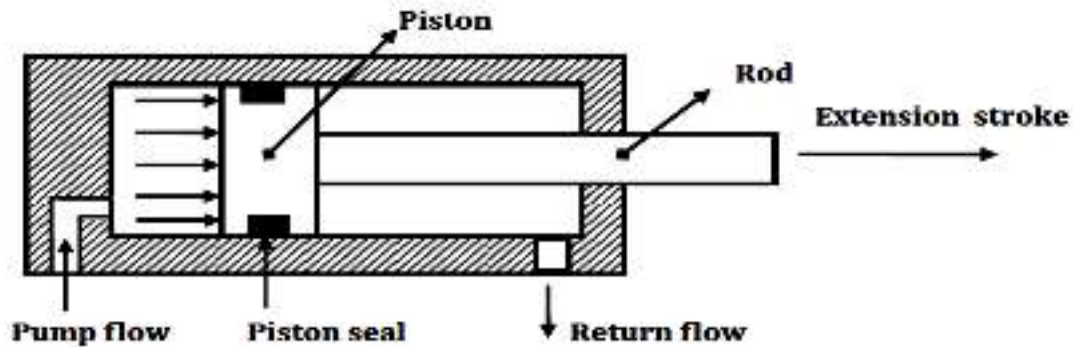

(a)

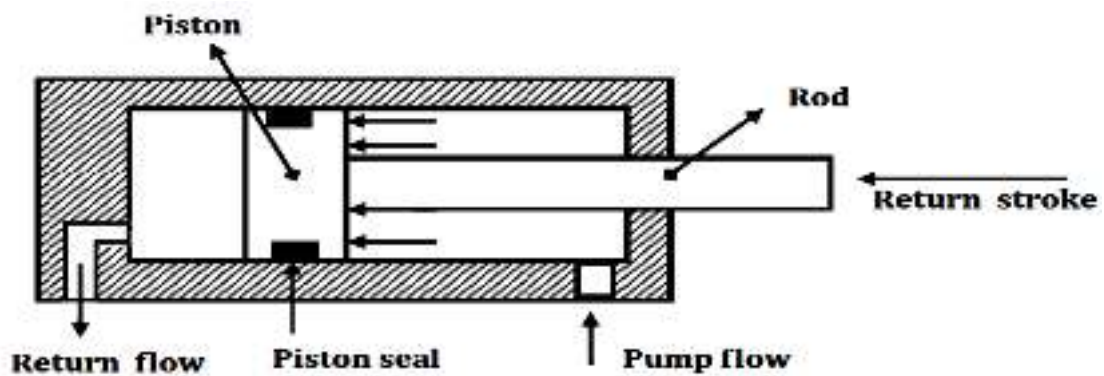

(b)

Figure shows the operation of a double-acting cylinder with a piston rod on one side. To extend the cylinder, the pump flow is sent to the blank-end port as in Fig.(a). The fluid from the rod-end port returns to the reservoir. To retract the cylinder, the pump flow is sent to the rod-end port and the fluid from the blank-end port returns to the tank as in Fig.(b).

DOUBLE ROD CYLINDERS:

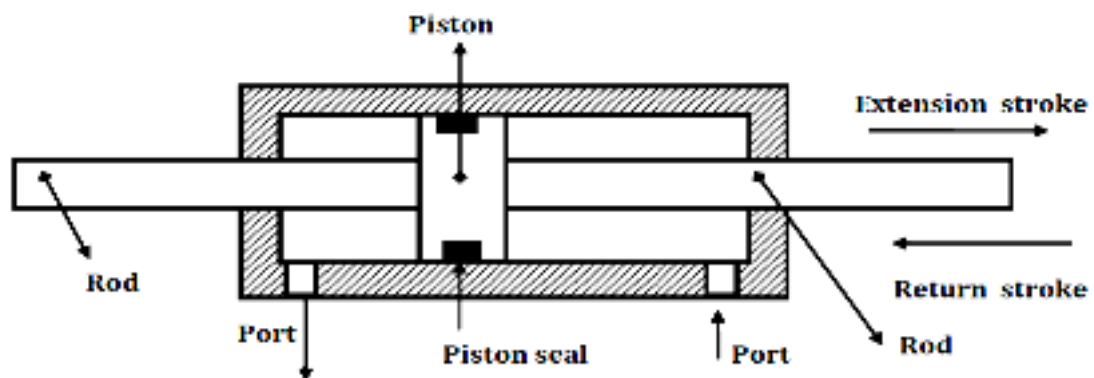

A double-acting cylinder with a piston rod on both sides is a cylinder with a rod extending from both ends. This cylinder can be used in an application where work can be done by both ends of the cylinder, thereby making the cylinder more productive. Double-rod cylinders can withstand higher side loads because they have an extra bearing, one on each rod, to withstand the loading.

TANDEM CYLINDERS:

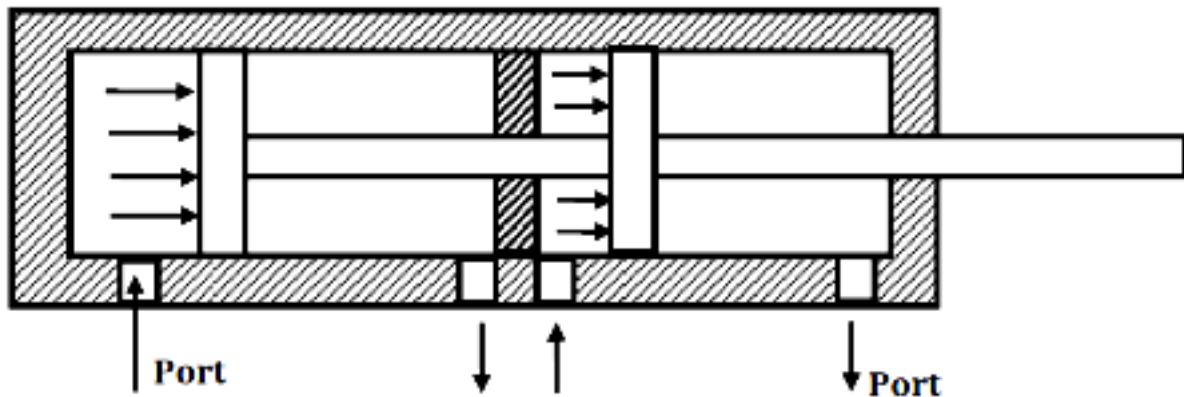

A tandem cylinder is used in applications where a large amount of force is required from a small-diameter cylinder. Pressure is applied to both pistons, resulting in increased force because of the larger area. The drawback is that these cylinders must be longer than a standard cylinder to achieve an equal speed because flow must go to both pistons.

CUSHIONED CYLINDERS:

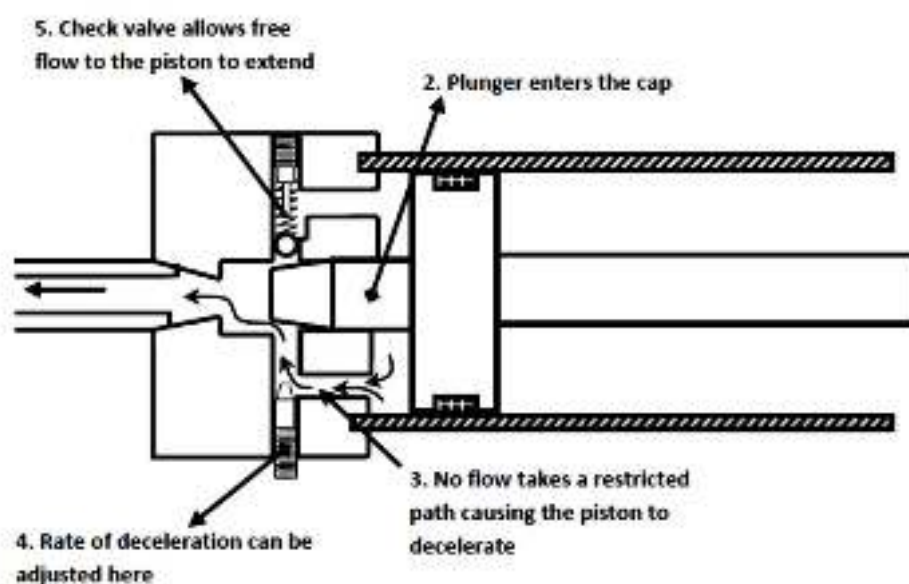

When the cylinder piston is actuated, the fluid enters the cylinder port and flows through the little check valve so that the entire piston area can be utilized to produce force and motion. For the prevention of shock due to stopping loads at the end of the piston stroke, cushion devices are used. Cushions may be applied at either end or both ends. They operate on the principle that as the cylinder piston approaches the end of stroke, an exhaust fluid is forced to go through an adjustable needle valve that is set to control the escaping fluid at a given rate. This allows the deceleration characteristics to be adjusted for different loads.

TELESCOPIC CYLINDERS:

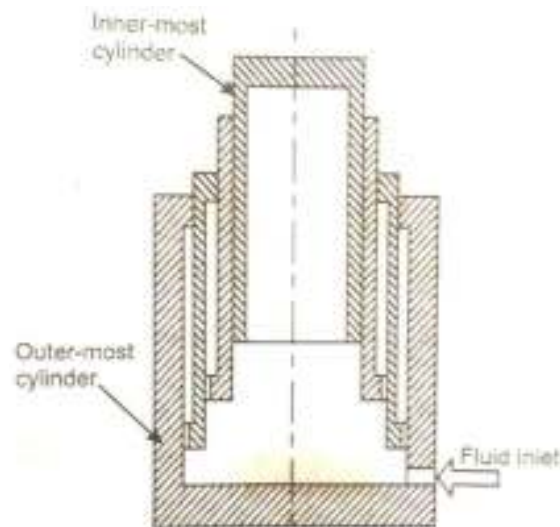

It has multiple cylinders that are mounted concentrically one within the other. The design is such that the inner most cylinder extends first, while the next cylinder extends after completion of the full stroke of the cylinder. Thus, each cylinder extends in stage, one after the other. Each stage of the cylinder has a sleeve that fits into the previous stage of the cylinder. The total stroke length achieved will be sum of the strokes of all the stages.

QUESTIONS FROM PREVIOUS YEAR QUESTION PAPERS:**DEC 2015/JAN 2016**

- 1) Explain the working and design of a vane pump.
- 2) A pump has a displacement volume of 120cm^3 . It delivers $1.5 \times 10^{-3} \text{ m}^3/\text{s}$ at 1440RPM and 60bar. If the prime mover input torque is 130 N-m and overall efficiency 88%, find theoretical discharge of the pump, volumetric efficiency of the pump, mechanical efficiency of the pump, overall efficiency.
- 3) A pump supplies oil at $0.0016 \text{ m}^3/\text{s}$ at a 40mm diameter double acting hydraulic cylinder. If the load is 500N and the rod dia is 20mm, find i) cylinder power during extension stroke ii) cylinder power during retraction stroke iii) pressure during extension and retraction stroke iv) piston velocity during extension and retraction stroke.

JUNE/JULY 2016

- 1) Explain the construction and working of an external gear pump.
- 2) Determine the volumetric efficiency of a gear pump of external diameter and internal diameter of gears 75mm and 50mm respectively and width of gear teeth 50mm, if the actual discharge is 30LPM at 1800rpm. [LPM = Litres per minute]
- 3) Sketch and explain double acting cylinder.

DEC 2016/JAN 2017

- 1) Explain the working of unbalanced vane pump. Also obtain an expression for its theoretical discharge.
- 2) A pump having a displacement of 25cm^3 , operates with a pressure of 250bar and speed of 1390rpm. Volumetric efficiency of 0.85 and mechanical efficiency of 0.80. calculate i) pump delivery in LPM ii) input power at pump shaft in KW iii) Drive Torque at pump shaft
- 3) An 8cm diameter hydraulic cylinder has 4cm diameter rod. If the cylinder receives the flow at 100LPM and 12Mpa. Find i) extension and retraction speeds ii) extension and retraction load carrying capacities.

JUNE/JULY 2017

- 1) With neat sketch explain the construction and working of a gear pump.
- 2) Determine the volumetric efficiency of a gear pump of external and internal diameters 75mm and 50mm respectively. Width of the gear teeth is 50mm. if the actual discharge is $30 \times 10^{-3} \text{ m}^3/\text{min}$ at 1800rpm.
- 3) With a neat sketch explain the working of linear actuator for single acting cylinder.

DEC 2017/JAN 2018

- 1) A gear pump has a 75mm outside diameter, a 50mm inside diameter and a 25mm width. If the volumetric efficiency is 90% at rated pressure, what is the corresponding actual flow rate? The pump speed is 1000rpm.
- 2) A pump has a displacement volume of 100 cm^3 . It delivers $0.0015 \text{ m}^3/\text{s}$ at 1000rpm and 70bars. If the prime mover input torque is 120N-m. Determine
 - i) What is the overall efficiency of the pump?
 - ii) What is the theoretical torque required to operate the pump?
- 3) A pump supplies oil at 75.8 litres/min to a 50.8mm diameter double-acting hydraulic cylinder. If the load is 4448 N (extending and retracting) and the rod diameter is 25.4mm, find
 - i) The hydraulic pressure during the extension and retraction stroke
 - ii) The piston velocity during the extension and retraction stroke
 - iii) The cylinder power during extension and retraction stroke
- 4) Explain with a neat sketch a Gear Pump.

JUNE/JULY 2018

- 1) With a neat diagram, explain the working principle of a typical hydraulic gear pump.
- 2) What is actuator? State its broad classification.
- 3) Explain the following single acting cylinders with neat sketches.
 - i) Gravity Type
 - ii) Spring Type
 - iii) Telescopic
 - iv) Tandem

CRASH COURSE – MAY 2017

- 1) What is the pressure compensated vane pump? How does it work? Explain with neat sketch.

- 2) A pump supplies oil at $0.0016\text{m}^3/\text{s}$ to a 40mm double acting hydraulic cylinder. If the load is 5000N (extending and retracted) and the rod diameter is 20mm, find the hydraulic pressure during extension and retraction stroke, piston velocity during extension and retraction stroke, cylinder power during the extension and retraction stroke.

ONE TIME EXIT SCHEME – APRIL 2018

- 1) Give the classification of pumps. With a neat sketch explain swash plate type piston pump.
- 2) A pump has a displacement of 98.4cm^3 . It delivers $0.00152\text{ m}^3/\text{s}$ of oil at 1000rpm and 70bar. If the prime mover input torque is 124.3N-m. Find i) Overall efficiency of pump; ii) theoretical torque required to operate the pump.
- 3) With a neat sketch, explain external gear pump.