

MODULE 2: DIGITAL TRANSMISSION (CONT.)

2.1 ANALOG TO DIGITAL CONVERSION

- An analog-signal may created by a microphone or camera.
- To change an analog-signal to digital-data, we use PCM (pulse code modulation).
- After the digital-data are created (digitization), then we convert the digital-data to a digital-signal.

2.1.1 PCM

- PCM is a technique used to change an analog signal to digital data (digitization).
- PCM has encoder at the sender and decoder at the receiver.
- The encoder has 3 processes (Figure 4.21):
 - 1) Sampling
 - 2) Quantization &
 - 3) Encoding.

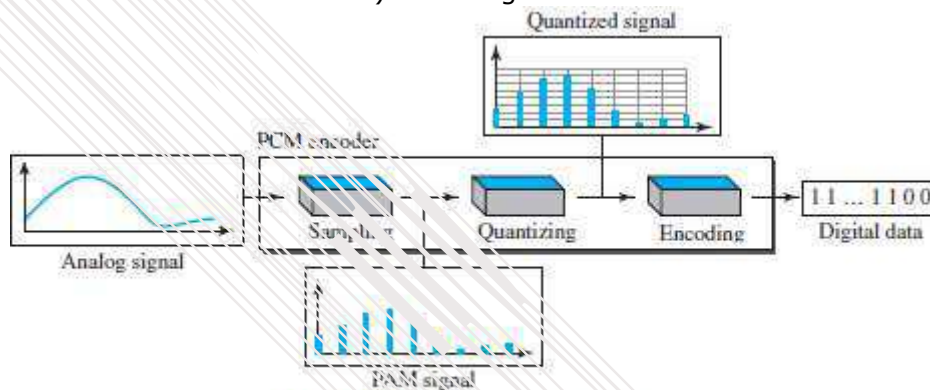

Figure 4.21 Components of PCM encoder

2.1.1.1 Sampling

- We convert the continuous time signal (analog) into the discrete time signal (digital).
- Pulses from the analog-signal are sampled every T_s sec where T_s is the sample-interval or period.
- The inverse of the sampling-interval is called the sampling-frequency (or sampling-rate).
- Sampling-frequency is given by

$$f_s = 1/T_s$$

- Three sampling methods (Figure 4.22):

1) Ideal Sampling

- This method is difficult to implement.

2) Natural Sampling

- A high-speed switch is turned ON for only the small period of time when the sampling occurs. The result is a sequence of samples that retains the shape of the analog-signal.

3) Flat Top Sampling

- The most common sampling method is sample and hold.

Sample and hold method creates flat-top samples.

- This method is sometimes referred to as *PAM* (pulse amplitude modulation).

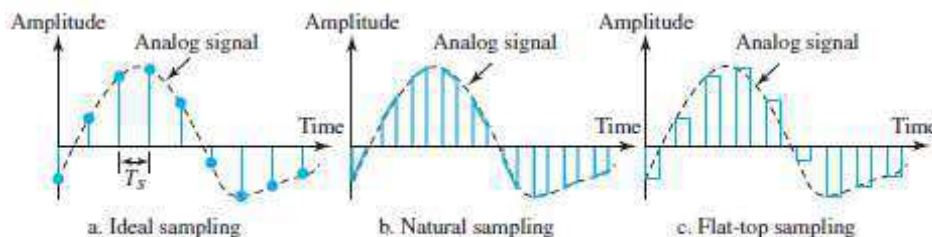

Figure 4.22 Three different sampling methods for PCM

DATA COMMUNICATION

2.1.1.1.1 Sampling Rate

- According to Nyquist theorem,
 - "The sampling-rate must be at least 2 times the highest frequency, not the bandwidth".
 - i) If the analog-signal is **low-pass**, the bandwidth and the highest frequency are the same value (Figure 4.23a).
 - ii) If the analog-signal is **bandpass**, the bandwidth value is lower than the value of the maximum frequency (Figure 4.23b).

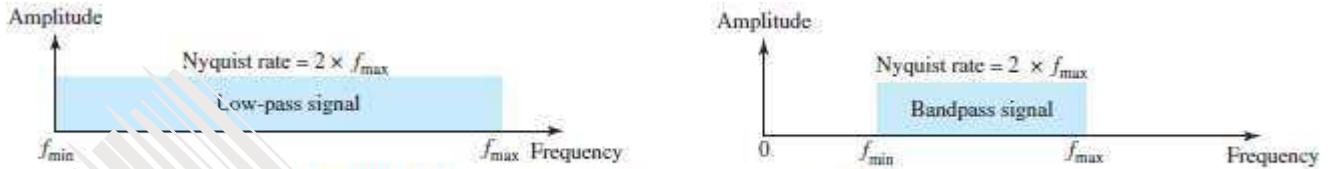

Figure 4.23 Nyquist sampling rate for low-pass and bandpass signals

2.1.2 Quantization

- The sampled-signal is quantized.
- Result of sampling is a set of pulses with amplitude-values b/w max & min amplitudes of the signal.
- Four steps in quantization:
 - We assume that the original analog-signal has amplitudes between V_{min} & V_{max} .
 - We divide the range into L zones, each of height Δ (delta).

$$\Delta = \frac{V_{max} - V_{min}}{L}$$

where L = number of levels.

- We assign quantized values of 0 to (L-1) to the midpoint of each zone.
- We approximate the value of the sample amplitude to the quantized values.

For example: Let $V_{min} = -20$ $V_{max} = +20$ V L = 8 Therefore, $\Delta = [+20 - (-20)]/8 = 5$ V

- In the chart (Figure 4.26),
 - First row is normalized-PAM-value for each sample.
 - Second row is normalized-quantized-value for each sample.
 - Third row is normalized error (which is diff. b/w normalized PAM value & quantized values).
 - Fourth row is quantization code for each sample.
 - Fifth row is the encoded words (which are the final products of the conversion).

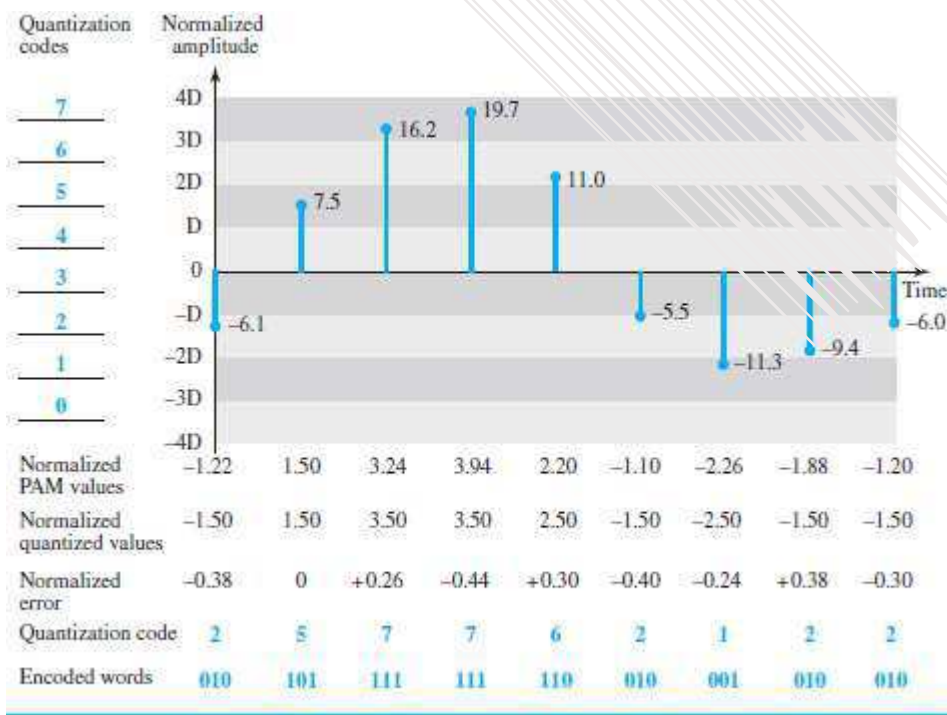

Figure 4.26 Quantization and encoding of a sampled signal

DATA COMMUNICATION

2.1.2.1 Quantization Level

- Let L = number of levels.
- The choice of L depends on
 - range of the amplitudes of the analog-signal and
 - how accurately we need to recover the signal.
- If the signal has only 2 amplitude values, we need only 2 quantization-levels.
If the signal (like voice) has many amplitude values, we need more quantization-levels.
- In audio digitizing, L is normally chosen to be 256.
In video digitizing, L is normally thousands.
- Choosing lower values of L increases the quantization-error.

2.1.2.2 Quantization Error

- Quantization-error is the difference b/w normalized PAM value & quantized values
- Quantization is an approximation process.
- The input values to the quantizer are the real values.
The output values from the quantizer are the approximated values.
- The output values are chosen to be the middle value in the zone.
- If the input value is also at the middle of the zone,
Then, there is no error.
Otherwise, there is an error.
- In the previous example,
The normalized amplitude of the third sample is 3.24, but the normalized quantized value is 3.50. This means that there is an error of +0.26.

2.1.2.3 Uniform vs. Non Uniform Quantization

- Non-uniform quantization can be done by using a process called companding and expanding.
 - 1) The signal is companded at the sender before conversion.
 - 2) The signal is expanded at the receiver after conversion.
- Companding means reducing the instantaneous voltage amplitude for large values.
Expanding means increasing the instantaneous voltage amplitude for small values.
- It has been proved that non-uniform quantization effectively reduces the SNR_{dB} of quantization.

2.1.3 Encoding

- The quantized values are encoded as n -bit code word.
- In the previous example,
A quantized value 2 is encoded as 010.
A quantized value 5 is encoded as 101.
- Relationship between number of quantization-levels (L) & number of bits (n) is given by
 $n = \log_2 L$ or $2^n = L$
- The bit-rate is given by:

$$\text{Bit rate} = \text{sampling rate} \times \text{number of bits per sample} = f_s \times n$$

Example 2.1

A complex low-pass signal has a bandwidth of 200 kHz. What is the minimum sampling rate for this signal?

Solution

The bandwidth of a low-pass signal is between 0 and f , where f is the maximum frequency in the signal. Therefore, we can sample this signal at 2 times the highest frequency (200 kHz). The sampling rate is therefore 400,000 samples per second.

Example 2.2

What is the SNR_{dB} in the example of Figure 4.26?

Solution

We can use the formula to find the quantization. We have eight levels and 3 bits per sample, so $SNR_{dB} = 6.02(3) + 1.76 = 19.82$ dB. Increasing the number of levels increases the SNR.

Example 2.3

A telephone subscriber line must have an SNR_{dB} above 40. What is the minimum number of bits per sample?

Solution

We can calculate the number of bits as

$$\text{SNR}_{\text{dB}} = 6.02n_b + 1.76 = 40 \rightarrow n = 6.35$$

Telephone companies usually assign 7 or 8 bits per sample.

Example 2.4

We want to digitize the human voice. What is the bit rate, assuming 8 bits per sample?

Solution

The human voice normally contains frequencies from 0 to 4000 Hz. So the sampling rate and bit rate are calculated as follows:

$$\begin{aligned} \text{Sampling rate} &= 4000 \times 2 = 8000 \text{ samples/s} \\ \text{Bit rate} &= 8000 \times 8 = 64,000 \text{ bps} = 64 \text{ kbps} \end{aligned}$$

2.1.3.1 Original Signal Recovery

- PCM decoder is used for recovery of the original signal.
- Here is how it works (Figure 4.27):
 - 1) The decoder first uses circuitry to convert the code words into a pulse that holds the amplitude until the next pulse.
 - 2) Next, the staircase-signal is passed through a low-pass filter to smooth the staircase signal into an analog-signal.
- The filter has the same cut-off frequency as the original signal at the sender.
- If the signal is sampled at the Nyquist sampling-rate, then the original signal will be re-created.
- The maximum and minimum values of the original signal can be achieved by using amplification.

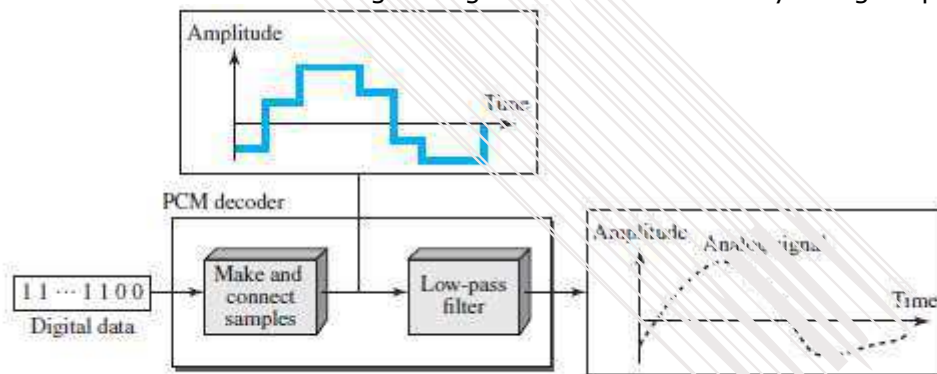

Figure 4.27 Components of a PCM decoder

2.1.3.2 PCM Bandwidth

- The minimum bandwidth of a line-encoded signal is

$$B_{\text{min}} = c \times N \times \frac{1}{r}$$

- We substitute the value of N in above formula:

$$B_{\text{min}} = c \times N \times \frac{1}{r} = c \times n_b \times f_s \times \frac{1}{r} = c \times n_b \times 2 \times B_{\text{analog}} \times \frac{1}{r}$$

- When $1/r = 1$ (for a NRZ or bipolar signal) and $c = (1/2)$ (the average situation), the minimum bandwidth is

$$B_{\text{min}} = n_b \times B_{\text{analog}}$$

- This means the minimum bandwidth of the digital-signal is n_b times greater than the bandwidth of the analog-signal.

DATA COMMUNICATION

2.1.3.3 Maximum Data Rate of a Channel

- The Nyquist theorem gives the data-rate of a channel as

$$N_{\max} = 2 \times B \times \log_2 L$$

- We can deduce above data-rate from the Nyquist sampling theorem by using the following arguments.

- 1) We assume that the available channel is low-pass with bandwidth B.
- 2) We assume that the digital-signal we want to send has L levels, where each level is a signalelement. This means $r = 1/\log_2 L$.
- 3) We first pass digital-signal through a low-pass filter to cut off the frequencies above B Hz.
- 4) We treat the resulting signal as an analog-signal and sample it at $2 \times B$ samples per second and quantize it using L levels.
- 5) The resulting bit-rate is

$$N = f_s \times n_b = 2 \times B \times \log_2 L$$

This is the maximum bandwidth; if the case factor c increases, the data-rate is reduced.

$$N = 2 \times B \times \log_2 L \text{ bps}$$

2.1.3.4 Minimum Required Bandwidth

- The previous argument can give us the minimum bandwidth if the data-rate and the number of signal-levels are fixed. We can say

$$B_{\min} = \frac{N}{(2 \times \log_2 L)} \text{ Hz}$$

DATA COMMUNICATION

2.2 TRANSMISSION MODES

- Two ways of transmitting data over a link (Figure 4.31): 1) Parallel mode & 2) Serial mode.

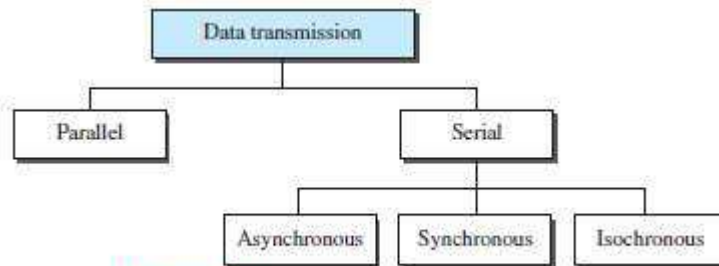

Figure 4.31 Data transmission and modes

2.1.1 PARALLEL TRANSMISSION

- Multiple bits are sent with each clock-tick (Figure 4.32).
- „n“ bits in a group are sent simultaneously.
- „n“ wires are used to send „n“ bits at one time.
- Each bit has its own wire.
- Typically, the 8 wires are bundled in a cable with a connector at each end.

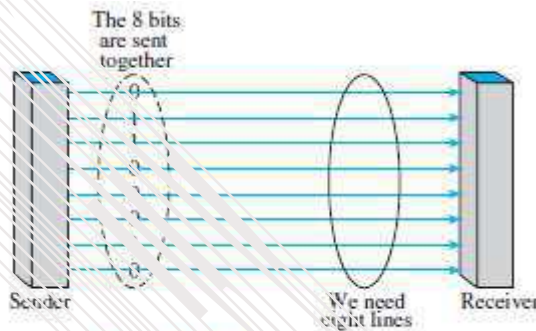

Figure 4.32 Parallel transmission

- Advantage:
 - 1) Speed: Parallel transmission can increase the transfer speed by a factor of n over serial transmission.
- Disadvantage:
 - 1) Cost: Parallel transmission requires n communication lines just to transmit the data-stream. Because this is expensive, parallel transmission is usually limited to short distances.

2.2.2 SERIAL TRANSMISSION

- One bit is sent with each clock-tick using only a single link (Figure 4.33).

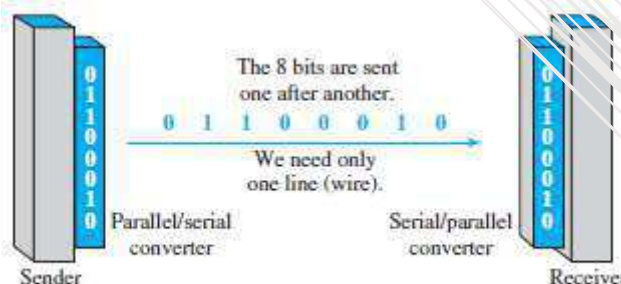

Figure 4.33 Serial transmission

- Advantage:
 - 1) Cost: Serial transmission reduces cost of transmission over parallel by a factor of n.
- Disadvantage:
 - 1) Since communication within devices is parallel, following 2 converters are required at interface:
 - i) Parallel-to-serial converter
 - ii) Serial-to-parallel converter
- Three types of serial transmission: asynchronous, synchronous, and isochronous.

DATA COMMUNICATION

2.2.2.1 Asynchronous Transmission

- Asynchronous transmission is so named because the timing of a signal is not important (Figure 4.34).
- Prior to data transfer, both sender & receiver agree on pattern of information to be exchanged.
- Normally, patterns are based on grouping the bit-stream into bytes.
- The sender transmits each group to the link without regard to a timer.
- As long as those patterns are followed, the receiver can retrieve the info. without regard to a timer.
- There may be a gap between bytes.
- We send
 - 1 start bit (0) at the beginning of each byte →
 - 1 stop bit (1) at the end of each byte.
- Start bit alerts the receiver to the arrival of a new group.
- Stop bit lets the receiver know that the byte is finished.
- Here, the term asynchronous means "asynchronous at the byte level".
- However, the bits are still synchronized & bit-durations are the same.

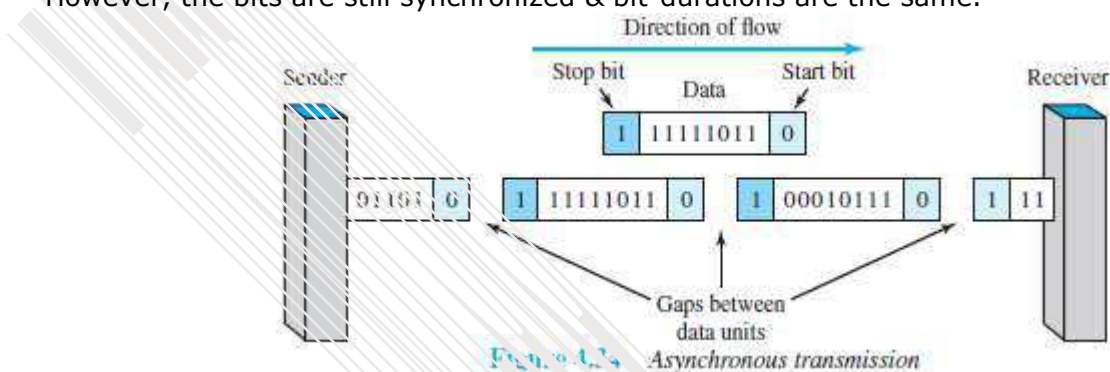

- Disadvantage:
 - 1) Slower than synchronous transmission. (Because of stop bit, start bit and gaps)
- Advantages:
 - 1) Cheap & effective.
 - 2) Useful for low-speed communication.

2.2.2.2 Synchronous Transmission

- We send bits one after another without start or stop bits or gaps (Figure 4.35).
- The receiver is responsible for grouping the bits.
- The bit-stream is combined into longer "frames," which may contain multiple bytes.
- If the sender wants to send data in separate bursts, the gaps b/w bursts must be filled with a special sequence of 0s & 1s (that means idle).

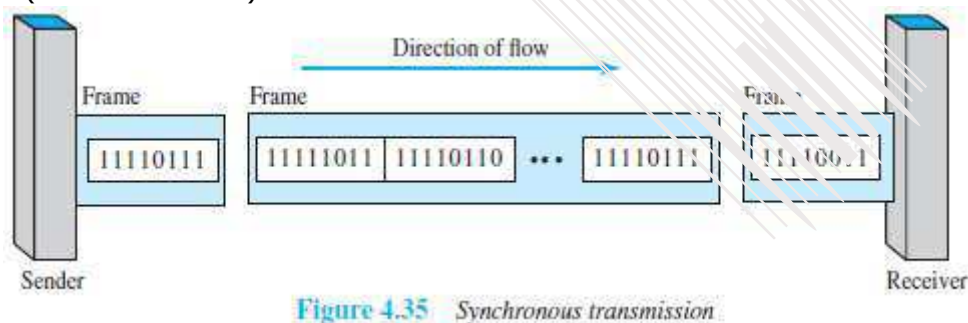

- Advantages:
 - 1) Speed: Faster than asynchronous transmission. („“ of no stop bit, start bit and gaps).
 - 2) Useful for high-speed applications such as transmission of data from one computer to another.

2.2.2.3 Isochronous

- Synchronization between characters is not enough; the entire stream of bits must be synchronized.
- The isochronous transmission guarantees that the data arrive at a fixed rate.
- In real-time audio/video, jitter is not acceptable. Therefore, synchronous transmission fails.
- For example: TV images are broadcast at the rate of 30 images per second. The images must be viewed at the same rate.

MODULE 2(CONT.): ANALOG TRANSMISSION

2.3 DIGITAL TO ANALOG CONVERSION

- Digital-to-analog conversion is the process of changing one of the characteristics of an analog-signal based on the information in digital-data (Figure 5.1).

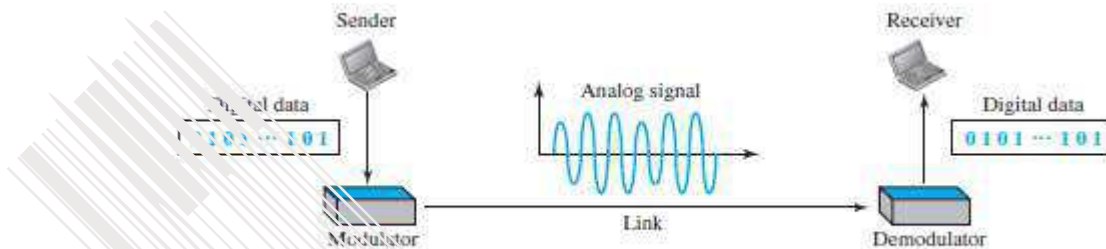

Figure 5.1 Digital-to-analog conversion

- A sine wave can be defined by 3 attributes:
 - 1) Amplitude
 - 2) Frequency &
 - 3) Phase.
- When anyone of the 3 attributes of a wave is varied, a different version of the wave will be created.
- So, by changing one attribute of an analog signal, we can use it to represent digital-data.
- Four methods of digital to analog conversion (Figure 5.2):
 - 1) Amplitude shift keying (ASK)
 - 2) Frequency shift keying (FSK)
 - 3) Phase shift keying (PSK)
 - 4) Quadrature amplitude modulation (QAM).
- QAM is a combination of ASK and PSK i.e. QAM combines changing both the amplitude and phase. QAM is the most efficient of these 4 methods. QAM is the method commonly used today.

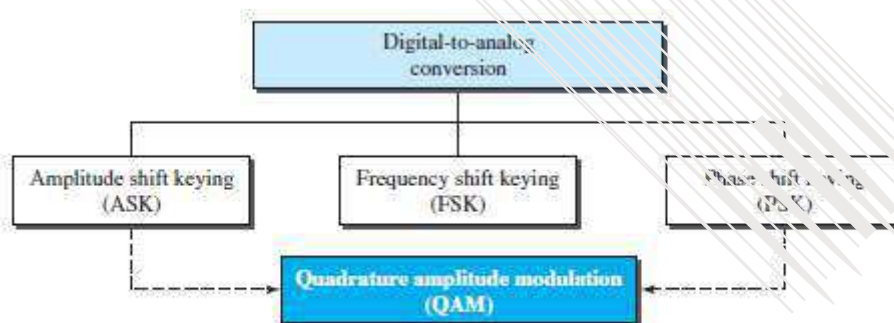

Figure 5.2 Types of digital-to-analog conversion

DATA COMMUNICATION

2.3.1 Aspects of Digital-to-Analog Conversion

1) Data Element vs. Signal Element

- A data-element is the smallest piece of information to be exchanged i.e. the bit.
- A signal-element is the smallest unit of a signal that is transmitted.

2) Data Rate vs. Signal Rate

- Data rate (Bit rate) is the number of bits per second.
 - Signal-rate (Baud rate) is the number of signal elements per second.
- The relationship between data-rate(N) and the signal-rate(S) is

$$S = N \times \frac{1}{r} \text{ baud}$$

where r = number of data-elements carried in one signal-element.

- The value of r is given by

$$r = \log_2 L \text{ or } 2^r = L$$

where L = type of signal-element (not the level)

(In transportation,

→ a baud is analogous to a vehicle, and

→ a bit is analogous to a passenger.

We need to maximize the number of people per car to reduce the traffic).

3) Carrier Signal

- The sender produces a high-frequency signal that acts as a base for the information-signal.
- This base-signal is called the carrier-signal (or carrier-frequency).
- The receiver is tuned to the frequency of the carrier-signal that it expects from the sender.
- Then, digital-information changes the carrier-signal by modifying its attributes (amplitude, frequency, or phase). This kind of modification is called modulation (shift keying).

4) Bandwidth

- In both ASK & PSK, the bandwidth required for data transmission is proportional to the signal-rate.
- In FSK, the bandwidth required is the difference between the two carrier-frequencies.

Example 2.5

An analog signal carries 4 bits per signal element. If 1000 signal elements are sent per second, find the bit rate.

Solution

In this case, $r = 4$, $S = 1000$, and N is unknown. We can find the value of N from

$$S = N \times (1/r) \quad \text{or} \quad N = S \times r = 1000 \times 4 = 4000 \text{ bps}$$

Example 2.6

An analog signal has a bit rate of 8000 bps and a baud rate of 1000 baud. How many signal elements are carried by each signal element? How many signal elements do we need?

Solution

In this example, $S = 1000$, $N = 8000$, and r and L are unknown. We first find the value of r and then the value of L .

$$S = N \times 1/r \quad \longrightarrow \quad r = N/S = 8000/10,000 = 8 \text{ bits/baud}$$

$$r = \log_2 L \quad \longrightarrow \quad L = 2^r = 2^8 = 256$$

DATA COMMUNICATION

2.3.2 Amplitude Shift Keying (ASK)

- The amplitude of the carrier-signal is varied to represent different signal-elements.
- Both frequency and phase remain constant for all signal-elements.

2.3.2.1 Binary ASK (BASK)

- BASK is implemented using only 2 levels. (Figure 5.3)
- This is also referred to as OOK (On-Off Keying).

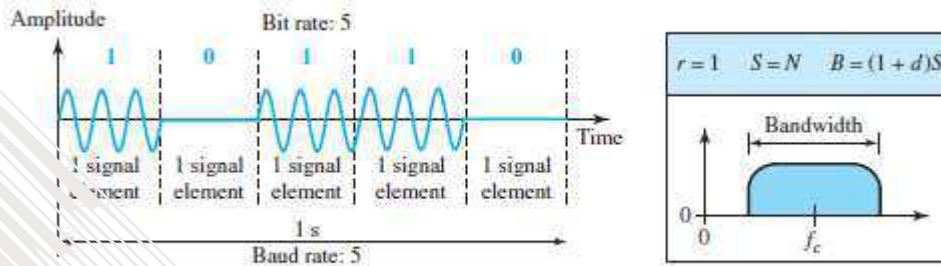

Figure 5.3 Binary amplitude shift keying

2.3.2.1.1 Implementation of BASK

- Here, line coding method used = unipolar NRZ (Figure 5.4).
- The unipolar NRZ signal is multiplied by the carrier-frequency coming from an oscillator.
 - 1) When amplitude of the NRZ signal = 0, amplitude of the carrier-signal = 0.
 - 2) When amplitude of the NRZ signal = 1, the amplitude of the carrier-signal is held.

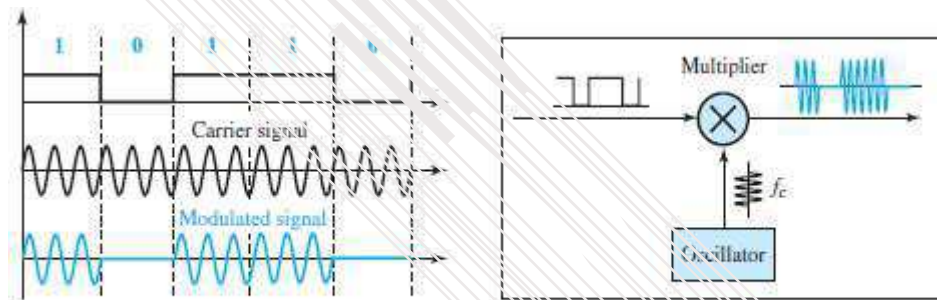

Figure 5.4 Implementation of binary ASK

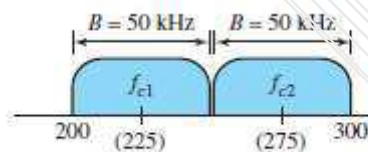

Figure 5.5 Bandwidth of full-duplex ASK

2.3.2.1.2 Bandwidth for ASK

- Here, the bandwidth (B) is proportional to the signal-rate (S) (Figure 5.5)
- The bandwidth is given by

$$B = (1 + d) \times S$$

where $d(0 < d < 1)$ = this factor depends on modulation and filtering-process.

Example 2.7

We have an available bandwidth of 100 kHz which spans from 200 to 300 kHz. What are the carrier frequency and the bit rate if we modulated our data by using ASK with $d = 1$?

Solution

The middle of the bandwidth is located at 250 kHz. This means that our carrier frequency can be at $f_c = 250$ kHz. We can use the formula for bandwidth to find the bit rate (with $d = 1$ and $r = 1$).

$$B = (1 + d) \times S = 2 \times N \times (1/r) = 2 \times N = 100 \text{ kHz} \rightarrow N = 50 \text{ kbps}$$

DATA COMMUNICATION

2.3.3 Frequency Shift Keying (FSK)

- The frequency of the carrier-signal is varied to represent different signal-elements.
- The frequency of the modulated-signal is constant for the duration of one signal-element, but changes for the next signal-element if the data-element changes.
- Both amplitude and phase remain constant for all signal-elements.

2.3.3.1 Binary FSK (BFSK)

- This uses 2 carrier-frequencies: f1 and f2. (Figure 5.6)
 - 1) When data-element = 1, first carrier frequency(f1) is used.
 - 2) When data-element = 0, second carrier frequency(f2) is used.

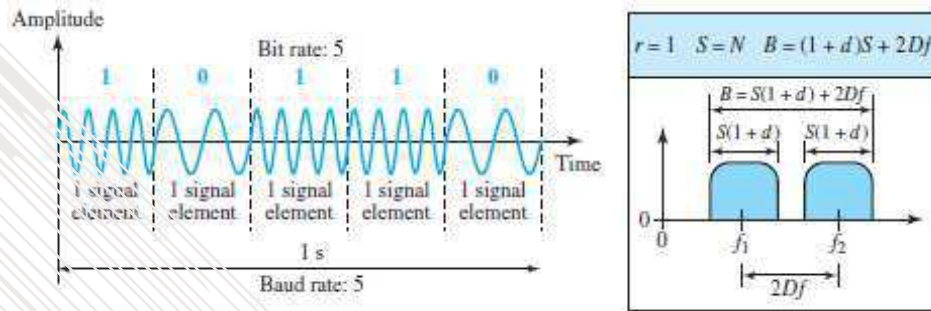

Figure 5.6 Binary frequency shift keying

2.3.3.1.1 Implementation

- Here, line coding method used = unipolar NRZ.
- Two implementations of BFSK: i) Coherent and ii) Non-Coherent.

Coherent BFSK	Non Coherent BFSK
The phase continues through the boundary of two signal-elements (Figure 5.7).	There may be discontinuity in the phase when one signal-element ends and the next begins.
This is implemented by using one voltage-controlled oscillator (VCO). VCO changes frequency according to the input voltage.	This is implemented by <ul style="list-style-type: none"> → treating BFSK as 2 ASK modulations and → using 2 carrier-frequencies
When the amplitude of NRZ signal = 0, the VCO keeps its regular frequency. When the amplitude of NRZ signal = 1, the VCO increases its frequency.	

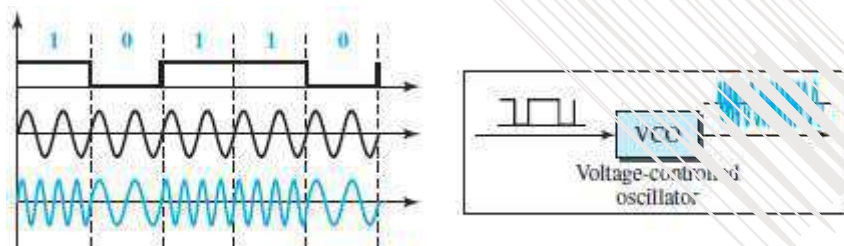

Figure 5.7 Implementation of BFSK

2.3.3.1.2 Bandwidth for BFSK

- FSK has two ASK signals, each with its own carrier-frequency f1 or f2. (Figure 5.6)
- The bandwidth is given by

$$B = (1 + d) \times S + 2\Delta f$$

where $2\Delta f$ is the difference between f_1 and f_2 ,

Example 2.8

We have an available bandwidth of 100 kHz which spans from 200 to 300 kHz. What should be the carrier frequency and the bit rate if we modulated our data by using FSK with $d = 1$?

Solution

This problem is similar to Example 5.3, but we are modulating by using FSK. The midpoint of the band is at 250 kHz. We choose $2\Delta f$ to be 50 kHz; this means

$$B = (1 + d) \times S + 2\Delta f = 100 \rightarrow 2S = 50 \text{ kHz} \rightarrow S = 25 \text{ kbaud} \rightarrow N = 25 \text{ kbps}$$

DATA COMMUNICATION

Example 2.9

We need to send data 3 bits at a time at a bit rate of 3 Mbps. The carrier frequency is 10 MHz. Calculate the number of levels (different frequencies), the baud rate, and the bandwidth.

Solution

We can have $L = 2^3 = 8$. The baud rate is $S = 3 \text{ MHz}/3 = 1 \text{ Mbaud}$. This means that the carrier frequencies must be 1 MHz apart ($2\Delta_f = 1 \text{ MHz}$). The bandwidth is $B = 8 \times 1 = 8 \text{ MHz}$. Figure 5.8 shows the allocation of frequencies and bandwidth.

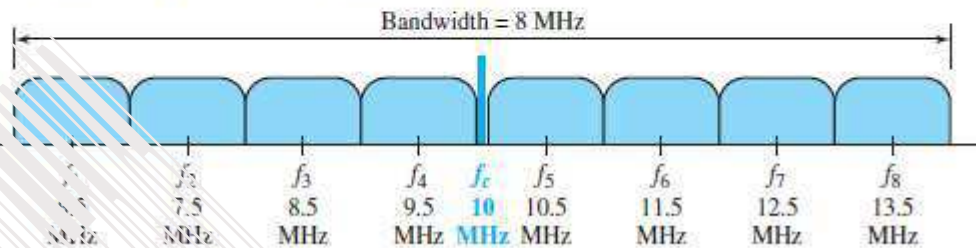

Figure 5.8 Bandwidth of MFSK used

DATA COMMUNICATION

2.3.4 Phase Shift Keying (PSK)

- The phase of the carrier-signal is varied to represent different signal-elements.
- Both amplitude and frequency remain constant for all signal-elements.

2.3.4.1 Binary PSK (BPSK)

- We have only two signal-elements:
 - 1) First signal-element with a phase of 0° .
 - 2) Second signal-element with a phase of 180° (Figure 5.9).
- ASK vs. PSK
 - In ASK, the criterion for bit detection is the amplitude of the signal.
 - In PSK, the criterion for bit detection is the phase.
- Advantages:
 - 1) PSK is less susceptible to noise than ASK.
 - 2) PSK is superior to FSK because we do not need 2 carrier-frequencies.
- Disadvantage:
 - 1) PSK is limited by the ability of the equipment to distinguish small differences in phase.

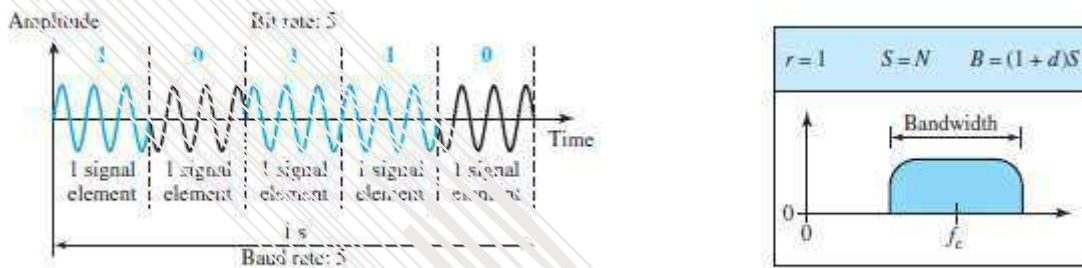

Figure 5.9 Binary phase shift keying

2.3.4.1.1 Implementation

- The implementation of BPSK is as simple as that for ASK. (Figure 5.10).
- The signal-element with phase 180° can be seen as the complement of the signal-element with phase 0° .
- Here, line coding method used: polar NRZ.
- The polar NRZ signal is multiplied by the carrier-frequency coming from an oscillator.
 - 1) When data-element = 1, the phase starts at 0° .
 - 2) When data-element = 0, the phase starts at 180° .

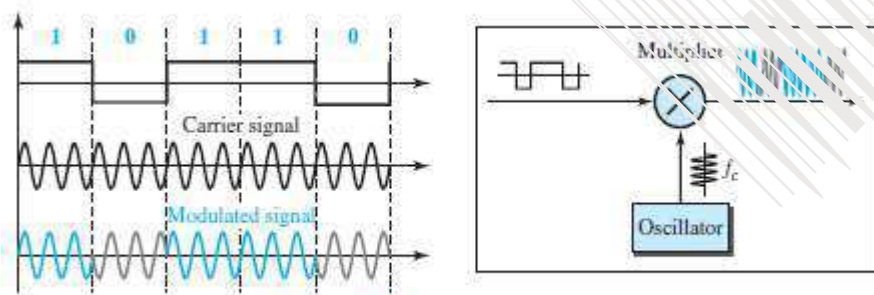

Figure 5.10 Implementation of BASK

2.3.4.1.2 Bandwidth for BPSK

- The bandwidth is the same as that for BASK, but less than that for BFSK. (Figure 5.9b)
- No bandwidth is wasted for separating 2 carrier-signals.

DATA COMMUNICATION

2.3.4.2 Quadrature PSK (QPSK)

- The scheme is called QPSK because it uses 2 separate BPSK modulations (Figure 5.11):
 - 1) First modulation is in-phase,
 - 2) Second modulation is quadrature (out-of-phase).
- A serial-to-parallel converter
 - accepts the incoming bits
 - sends first bit to first modulator and
 - sends second bit to second modulator.
- The bit to each BPSK signal has one-half the frequency of the original signal.
- Advantages:
 - 1) Decreases the baud rate.
 - 2) Decreases the required bandwidth.

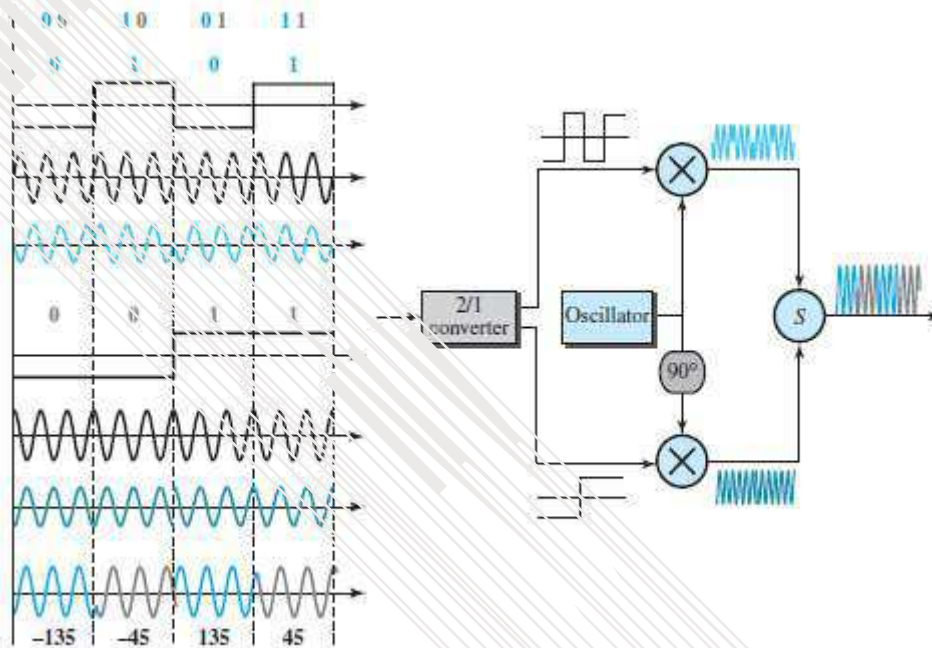

Figure 5.11 QPSK and its implementation

- As shown in Figure 5.11, the 2 composite-signals created by each multiplier are 2 sine waves with the same frequency, but different phases.
- When the 2 sine waves are added, the result is another sine wave, with 4 possible phases: 45°, -45°, 135°, and -135°.
- There are 4 kinds of signal-elements in the output signal ($L=4$), so we can send 2 bits per signalelement ($r=2$).

Example 2.10

Find the bandwidth for a signal transmitting at 12 Mbps for QPSK. The value of $d = 0$.

Solution

For QPSK, 2 bits are carried by one signal element. This means that $r = 2$. So the signal rate (baud rate) is $S = N \times (1/r) = 6$ Mbaud. With a value of $d = 0$, we have $B = S = 6$ MHz.

DATA COMMUNICATION

2.3.4.3 Constellation Diagram

- A constellation diagram can be used to define the amplitude and phase of a signal-element.
- This diagram is particularly useful
 - when 2 carriers (one in-phase and one quadrature) are used. → when dealing with multilevel ASK, PSK, or QAM.
- In a constellation diagram, a signal-element type is represented as a dot.
- The diagram has 2 axes (Figure 5.12):
 - 1) The horizontal X axis is related to the in-phase carrier.
 - 2) The vertical Y axis is related to the quadrature carrier.
- For each point on the diagram, 4 pieces of information can be deduced.
 - 1) The projection of point on the X axis defines the peak amplitude of the in-phase component.
 - 2) The projection of point on Y axis defines peak amplitude of the quadrature component.
 - 3) The length of the line that connects the point to the origin is the peak amplitude of the signal-element (combination of the X and Y components);
 - 4) The angle the line makes with the X axis is the phase of the signal-element.

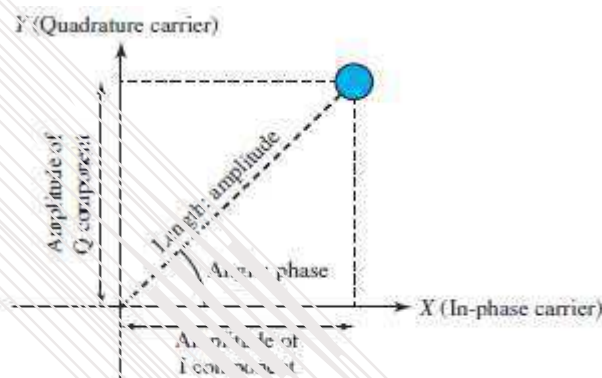

Figure 5.12 Concept of a constellation diagram

Example 2.11

Show the constellation diagrams for ASK (OOK), BPSK, and QPSK signals.

Solution

Figure 5.13 shows the three constellation diagrams. Let us analyze each case separately:

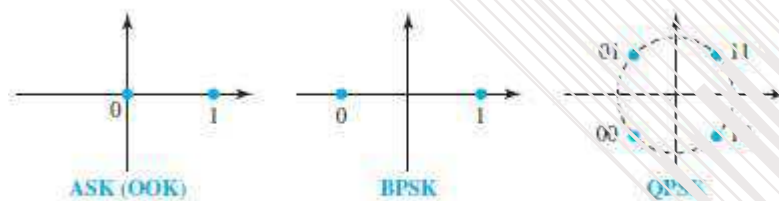

Figure 5.13 Three constellation diagrams

DATA COMMUNICATION

2.3.5 Quadrature Amplitude Modulation (QAM)

- This is a combination of ASK and PSK.
- Main idea: Using 2 carriers, one in-phase and the other quadrature, with different amplitude levels for each carrier.
- There are many variations of QAM (Figure 5.14).
 - A) Figure 5.14a shows the 4-QAM scheme using a unipolar NRZ signal. This is same as BASK.
 - B) Figure 5.14b shows another QAM using polar NRZ. This is the same as QPSK.
 - C) Figure 5.14c shows another 4-QAM in which we used a signal with 2 positive levels to modulate each of the 2 carriers.
 - D) Figure 5.14d shows a 16-QAM constellation of a signal with 8 levels, 4 positive & 4 negative.

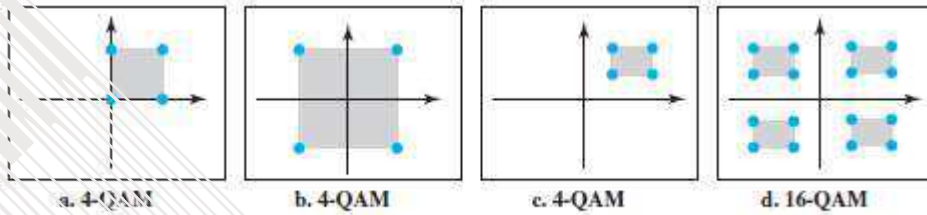

Figure 5.14 Constellation diagrams for some QAMs

2.3.5.1 Bandwidth for QAM

- The bandwidth is same as in ASK and PSK transmission.
- QAM has the same advantages as PSK over ASK.

MODULE 2(CONT.): BANDWIDTH UTILIZATION -- MULTIPLEXING AND SPREADING

2.4 MULTIPLEXING

- When bandwidth of a medium is greater than bandwidth needs of the devices, the link can be shared.
- *Multiplexing* allows simultaneous transmission of multiple signals across a single data-link (Fig 4.21).
- The traffic increases, as data/telecommunications use increases.
- We can accommodate this increase by
 - adding individual links, each time a new channel is needed or
 - installing higher-bandwidth links to carry multiple signals.
- Today's technology includes high-bandwidth media such as optical-fiber and satellite microwaves.
- Each has a bandwidth far in excess of that needed for the average transmission-signal.
- If the bandwidth of a link is greater than the bandwidth needs of the devices connected to it, the bandwidth is wasted.
- An efficient system maximizes the utilization of all resources; bandwidth is one of the most precious resources we have in data communications.

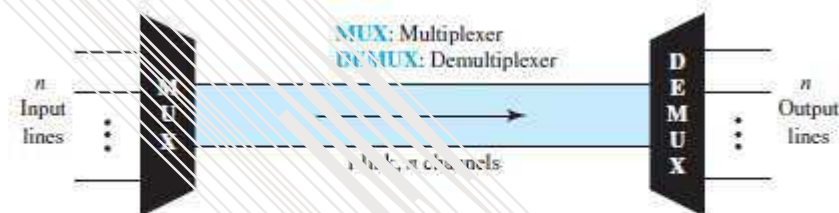

Figure 6.1 *Dividing a link into channels*

- In a multiplexed-system, „n“ lines share the bandwidth of one link.
- MUX combines transmission-streams from different input-lines into a single stream (many-to-one).
- At the receiving-end, that stream is fed into a demultiplexer (DEMUX).
- DEMUX
 - separates the stream back into its component-transmissions (one-to-many) and → directs the transmission-streams to different output-lines.
- Link vs. Channel:
 - 1) The link refers to the physical path.
 - 2) The channel refers to the portion of a link that carries a transmission between a given pair of lines. One link can have many channels.
- Three multiplexing techniques (Figure 6.2):
 - 1) Frequency-division multiplexing (FDM)
 - 2) Wavelength-division multiplexing (WDM) and
 - 3) Time-division multiplexing (TDM).
- The first two techniques are used for analog-signals.
The third one technique is used for digital-signals.

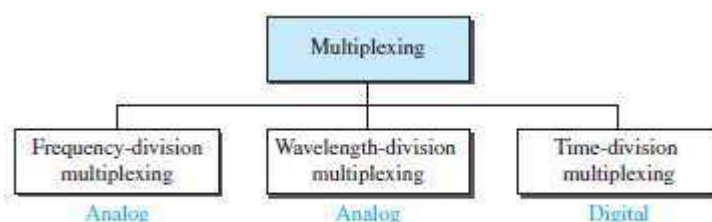

Figure 6.2 *Categories of multiplexing*

DATA COMMUNICATION

2.4.1 Frequency Division Multiplexing (FDM)

- FDM is an analog multiplexing technique that combines analog signals (Figure 6.3).
- FDM can be used when the bandwidth of a link is greater than the combined bandwidths of the signals to be transmitted. (Bandwidth measured in hertz).

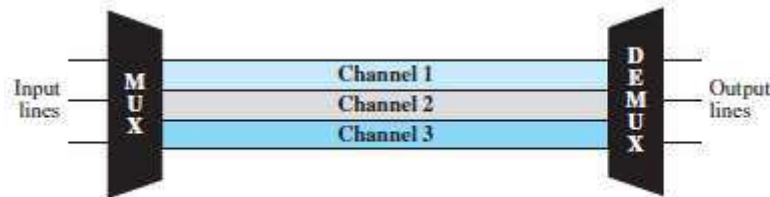

Figure 6.3 Frequency-division multiplexing

2.4.1.1 Multiplexing Process

- Here is how it works (Figure 6.4):
 - 1) Each sending-device generates modulated-signals with different carrier-frequencies (f_1 , f_2 , & f_3).
 - 2) Then, these modulated-signals are combined into a single multiplexed-signal.
 - 3) Finally, the multiplexed-signal is transported by the link.

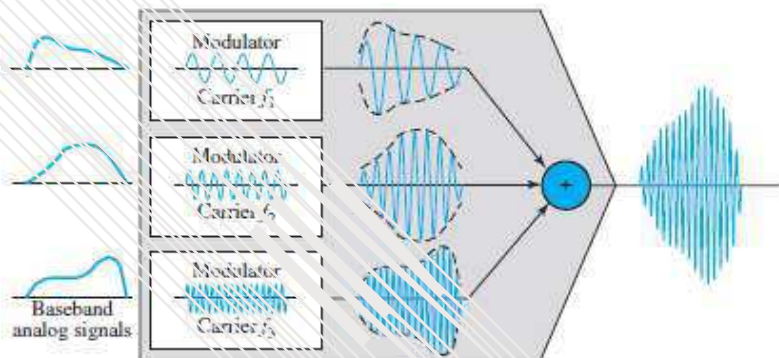

Figure 6.4 FDM process

- Carrier-frequencies are separated by sufficient bandwidth to accommodate the modulated-signal.
- Channels can be separated by strips of unused bandwidth called guard bands.
- Guard bands prevent signals from overlapping.
- In addition, carrier-frequencies must not interfere with the original data frequencies.
- Although FDM is considered as analog multiplexing technique, the sources can produce digital-signal.
- The digital-signal can be sampled, changed to analog-signal, and then multiplexed by using FDM.

2.4.1.2 Demultiplexing Process

- Here is how it works (Figure 6.5):
 - 1) The demultiplexer uses filters to divide the multiplexed-signal into individual-signals.
 - 2) Then, the individual signals are passed to a demodulator.
 - 3) Finally, the demodulator
 - separates the individual signals from the carrier signals and →
 - passes the individual signals to the output-lines.

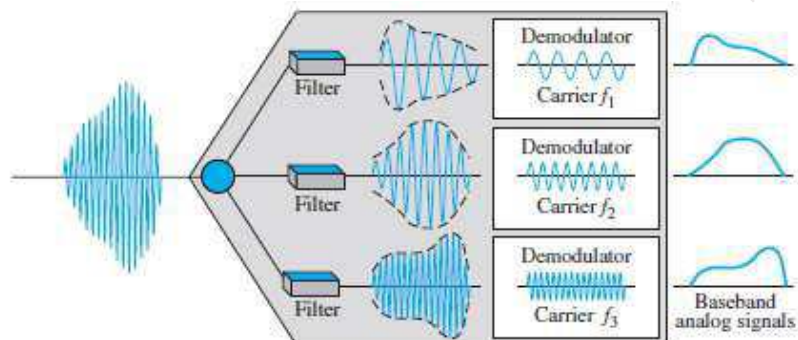

Figure 6.5 FDM demultiplexing example

Example 2.12

Assume that a voice channel occupies a bandwidth of 4 kHz. We need to combine three voice channels into a link with a bandwidth of 12 kHz, from 20 to 32 kHz. Show the configuration, using the frequency domain. Assume there are no guard bands.

Solution

We shift (modulate) each of the three voice channels to a different bandwidth, as shown in Figure 6.6. We use the 20- to 24-kHz bandwidth for the first channel, the 24- to 28-kHz bandwidth for the second channel, and the 28- to 32-kHz bandwidth for the third one. Then we combine them as shown in Figure 6.6.

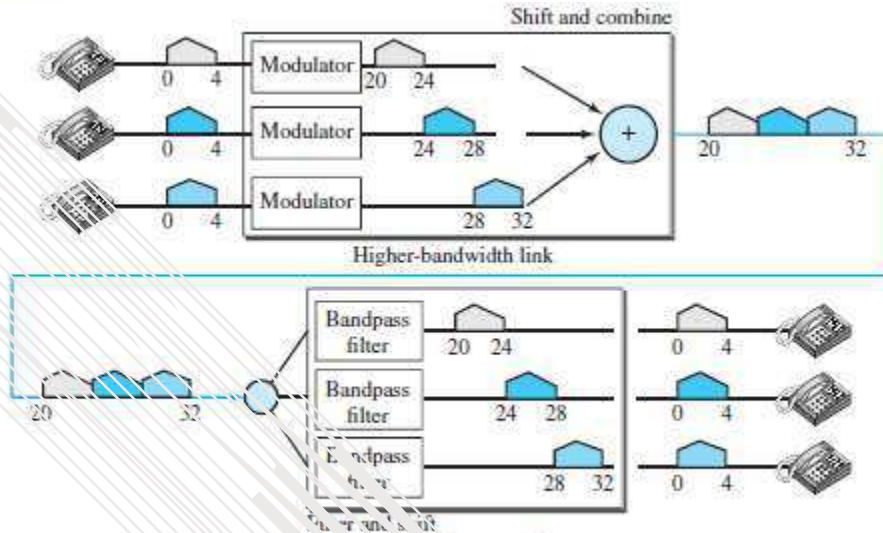

Figure 6.6

Example 2.13

Five channels, each with a 100-kHz bandwidth, are to be multiplexed together. What is the minimum bandwidth of the link if there is a need for a guard band of 10 kHz between the channels to prevent interference?

Solution

For five channels, we need at least four guard bands. This means that the required bandwidth is at least $5 \times 100 + 4 \times 10 = 540$ kHz, as shown in Figure 6.7.

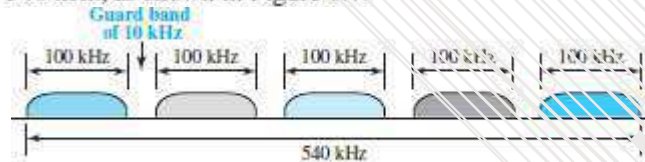

Figure 6.7

Example 2.14

Four data channels (digital), each transmitting at 1 Mbps, use a satellite channel of 1 MHz. Design an appropriate configuration, using FDM.

Solution

The satellite channel is analog. We divide it into four channels, each channel having a 250-kHz bandwidth. Each digital channel of 1 Mbps is modulated so that each 4 bits is modulated to 1 Hz. One solution is 16-QAM modulation. Figure 6.8 shows one possible configuration.

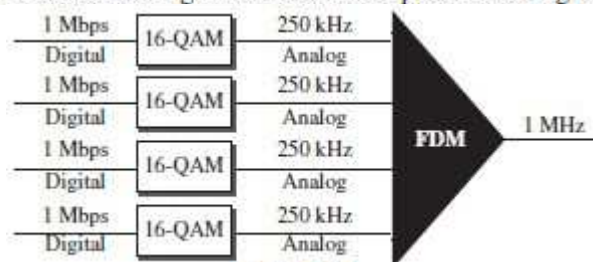

Figure 6.8

DATA COMMUNICATION

2.4.1.3 Applications of FDM

- 1) To maximize the efficiency of their infrastructure, Telephone-companies have traditionally multiplexed signals from lower-bandwidth lines onto higher-bandwidth lines.
- 2) A very common application of FDM is AM and FM radio broadcasting.
- 3) The first generation of cellular telephones (still in operation) also uses FDM.

2.4.1.4 Analog Carrier System

- To maximize the efficiency, telephone-companies have multiplexed-signals from lower-bandwidth lines onto higher-bandwidth lines.
- Many switched or leased lines are combined into bigger channels.
- For analog lines, FDM is used.
- One of these hierarchical systems used by AT&T is made up of (Figure 6.9):

- 1) Groups
- 2) Super groups
- 3) Master groups, and
- 4) Jumbo groups

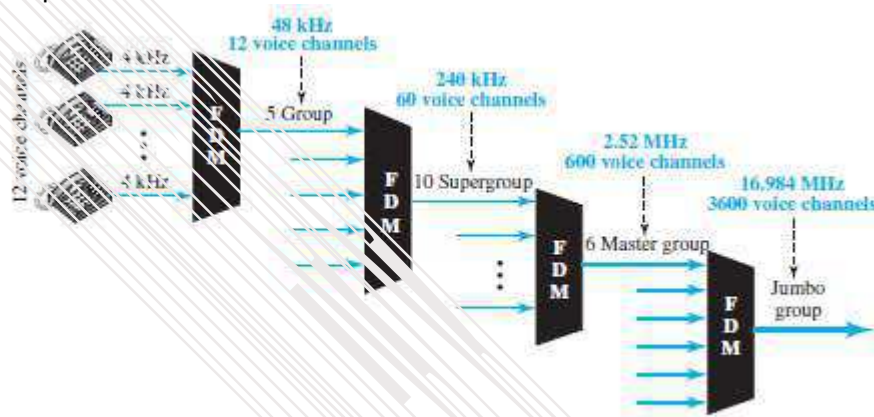

Figure 6.9 Analog hierarchy

- 1) Group:** In the analog hierarchy, 12 voice channels are multiplexed onto a higher-bandwidth line to create a group.
 - A group has 48 kHz of bandwidth and supports 12 voice channels.
- 2) Super Group:** At the next level, up to five groups can be multiplexed to create a composite signal called a supergroup.
 - A supergroup has a bandwidth of 240 kHz and supports up to 60 voice channels.
 - Supergroups can be made up of either five groups or 60 independent voice channels.
- 3) Master Groups:** At the next level, 10 supergroups are multiplexed to create a master group.
 - A master group must have 2.40 MHz of bandwidth, but the need for guard bands between the supergroups increases the necessary bandwidth to 2.52 MHz.
 - Master groups support up to 600 voice channels.
- 4) Jumbo Group:** Finally, six master groups can be combined into a jumbo group.
 - A jumbo group must have 15.12 MHz (6 x 2.52 MHz) of bandwidth, but the need for guard bands b/w the master groups increases the necessary bandwidth to 16.984 MHz

Example 2.15

The Advanced Mobile Phone System (AMPS) uses two bands. The first band of 824 to 849 MHz is used for sending, and 869 to 894 MHz is used for receiving. Each user has a bandwidth of 30 kHz in each direction. The 3-kHz voice is modulated using FM, creating 30 kHz of modulated signal. How many people can use their cellular phones simultaneously?

Solution

Each band is 25 MHz. If we divide 25 MHz by 30 kHz, we get 833.33. In reality, the band is divided into 832 channels. Of these, 42 channels are used for control, which means only 790 channels are available for cellular phone users.

2.4.2 Wavelength Division Multiplexing (WDM)

- WDM is an analog multiplexing technique that combines analog signals (Figure 6.10).
- WDM is designed to use the high-data-rate capability of fiber optical-cable.
- The data-rate of optical-cable is higher than the data-rate of metallic-cable.
- Using an optical-cable for one single line wastes the available bandwidth.
- Multiplexing allows combining several lines into one line.
- WDM is same as FDM with 2 exceptions:
 - 1) Multiplexing & demultiplexing involve optical-signals transmitted through optical-cable.
 - 2) The frequencies are very high.

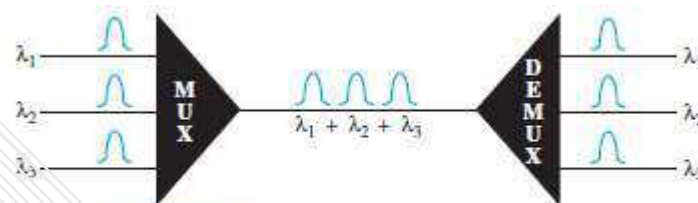

Figure 6.10 Wavelength-division multiplexing

- Here is how it works (Figure 6.11):
 - A multiplexer combines several narrow-bands of light into a wider-band of light.
 - A demultiplexer divides a wider-band of light into several narrow-bands of light.
 - A prism is used for combining and splitting of light sources
 - A prism bends a beam of light based on
 - angle of incidence and
 - frequency.

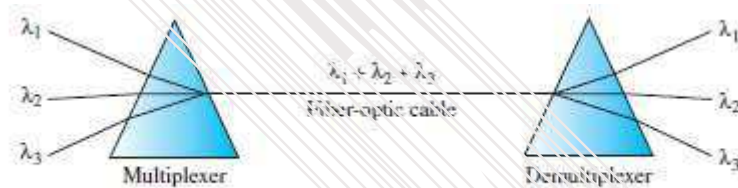

Figure 6.11 Prisms in wavelength-division multiplexing and demultiplexing

- Applications of WDM:
 - 1) SONET network: Multiple optical-fiber lines can be multiplexed and demultiplexed.
 - 2) Dense WDM (DWDM) can multiplex a very large number of channels by spacing channels very close to one another. DWDM achieves even greater efficiency

DATA COMMUNICATION

2.4.3 Time Division Multiplexing (TDM)

- TDM is a digital multiplexing technique that combines digital signals (Figure 6.12).
- TDM combines several low-rate channels into one high-rate one.
- FDM vs. TDM
 - 1) In FDM, a portion of the bandwidth is shared.
 - 2) In TDM, a portion of the time is shared.
- Each connection occupies a portion of time in the link.
- Several connections share the high bandwidth of a line.

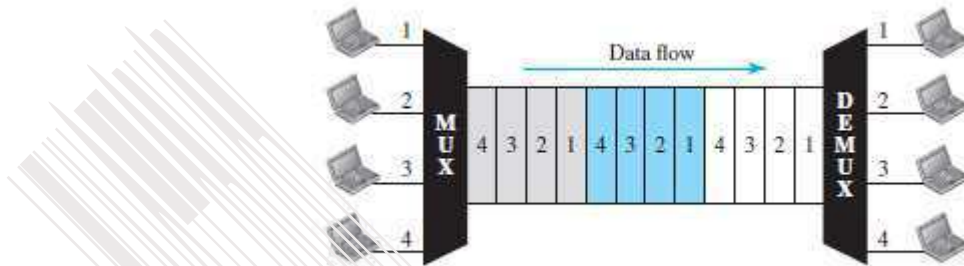

Figure 6.12 TDM

- As shown in Figure 6.12, the link is divided by time.
- Portions of signals 1, 2, 3, and 4 occupy the link sequentially.
- Digital-data from different sources are combined into one timeshared link.
- Although TDM is considered as digital multiplexing technique, the sources can produce analog-signal.
- The analog data can be sampled, changed to digital-data, and then multiplexed by using TDM.
- Two types of TDM:
 - 1) Synchronous and
 - 2) Statistical.

DATA COMMUNICATION

2.4.3.1 Synchronous TDM

2.4.3.1.1 Time Slots & Frames

- Each input-connection has an allotment in the output-connection even if it is not sending data.
- The data-flow of input-connection is divided into units (Figure 6.13).
- A unit can be 1 bit, 1 character, or 1 block of data.
- Each input-unit occupies one input-time-slot.
- Each input-unit
 - becomes one output-unit and
 - occupies one output-time-slot.
- However, duration of output-time-slot is „n“ times shorter than duration of input-time-slot.
- If an input-time-slot is T s, the output-time-slot is T/n s

where n = No. of connections.
- In the output-connection, a unit has a shorter duration & therefore travels faster.

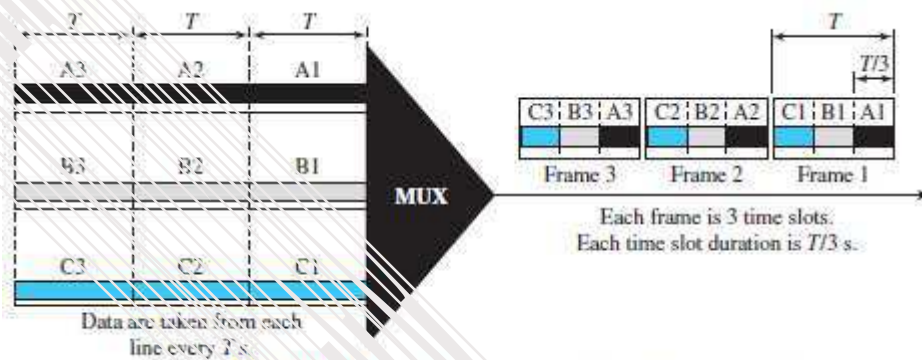

Figure 6.13 Synchronous time-division multiplexing

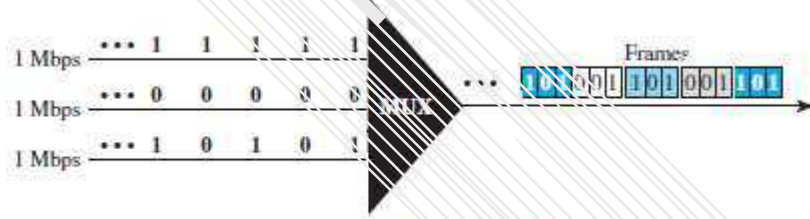

Figure 6.14

- In Figure 6.14, n = 3.
- A set of data-units from each input-connection is grouped into a frame.
- For example:
 - If there are 3 connections, a frame is divided into 3 time-slots.
 - One slot is allocated for each data-unit.
 - One data-unit is used for each input-line.

Example 2.16

In Figure 6.13, the data rate for each input connection is 1 kbps. If 1 bit at a time is multiplexed (a unit is 1 bit), what is the duration of

1. each input slot,
2. each output slot, and
3. each frame?

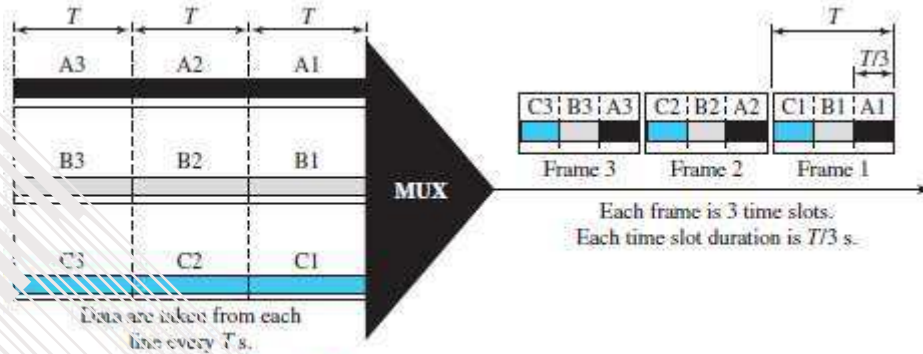

Figure 6.13 Synchronous time-division multiplexing

Solution

We can answer the questions as follows:

1. The data rate of each input connection is 1 kbps. This means that the bit duration is $1/1000$ s or 1 ms. The duration of the input time slot is 1 ms (same as bit duration).
2. The duration of each output time slot is one-third of the input time slot. This means that the duration of the output time slot is $1/3$ ms.
3. Each frame carries three output time slots. So the duration of a frame is $3 \times 1/3$ ms, or 1 ms. The duration of a frame is the same as the duration of an input unit.

Example 2.17

Figure 6.14 shows synchronous TDM with a data stream for each input and one data stream for the output. The unit of data is 1 bit. Find (1) the input bit duration, (2) the output bit duration, (3) the output bit rate, and (4) the output frame rate.

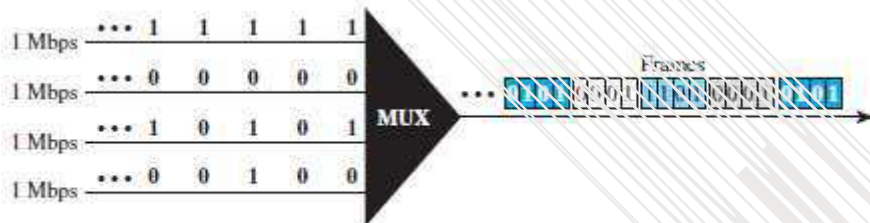

Figure 6.14

Solution

We can answer the questions as follows:

1. The input bit duration is the inverse of the bit rate: $1/1 \text{ Mbps} = 1 \mu\text{s}$.
2. The output bit duration is one-fourth of the input bit duration, or $1/4 \mu\text{s}$.
3. The output bit rate is the inverse of the output bit duration, or $1/4 \mu\text{s}$, or 4 Mbps. This can also be deduced from the fact that the output rate is 4 times as fast as any input rate; so the output rate = $4 \times 1 \text{ Mbps} = 4 \text{ Mbps}$.
4. The frame rate is always the same as any input rate. So the frame rate is 1,000,000 frames per second. Because we are sending 4 bits in each frame, we can verify the result of the previous question by multiplying the frame rate by the number of bits per frame.

DATA COMMUNICATION

Example 2.18

Four 1-kbps connections are multiplexed together. A unit is 1 bit. Find (1) the duration of 1 bit before multiplexing, (2) the transmission rate of the link, (3) the duration of a time slot, and (4) the duration of a frame.

Solution

We can answer the questions as follows:

1. The duration of 1 bit before multiplexing is $1/1$ kbps, or 0.001 s (1 ms).
2. The rate of the link is 4 times the rate of a connection, or 4 kbps.
3. The duration of each time slot is one-fourth of the duration of each bit before multiplexing, or $1/4$ ms or 250 μ s. Note that we can also calculate this from the data rate of the link, 4 kbps. The bit duration is the inverse of the data rate, or $1/4$ kbps or 250 μ s.
4. The duration of a frame is always the same as the duration of a unit before multiplexing, or 1 ms. We can also calculate this in another way. Each frame in this case has four time slots. So the duration of a frame is 4 times 250 μ s, or 1 ms.

DATA COMMUNICATION

2.4.3.1.2 Interleaving

- TDM can be seen as 2 fast-rotating switches (Figure 6.15):
 - 1) First switch on the multiplexing-side and
 - 2) Second switch on the demultiplexing-side.
- The switches are synchronized and rotate at the same speed, but in opposite directions.
 - 1) On the multiplexing-side (Figure 6.16)
 - As the switch opens in front of a connection, that connection has the opportunity to send a unit onto the path. This process is called *interleaving*.
 - 2) On the demultiplexing-side
 - As the switch opens in front of a connection, that connection has the opportunity to receive a unit from the path.

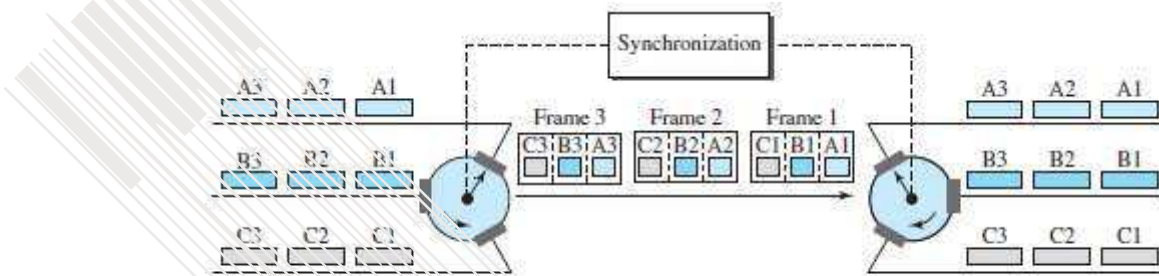

Figure 6.15 Interleaving

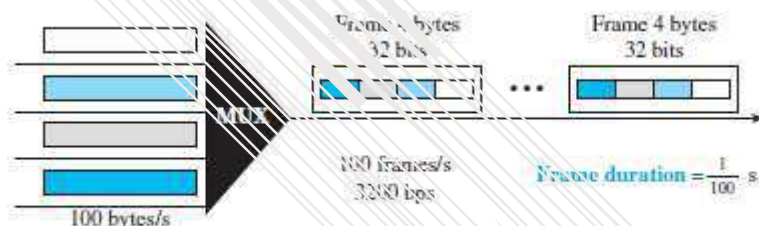

Figure 6.16

Example 2.19

Four channels are multiplexed using TDM. If each channel sends 100 bytes/s and we multiplex 1 byte per channel, show the frame traveling on the link, the size of the frame, the duration of a frame, the frame rate, and the bit rate for the link.

Solution

The multiplexer is shown in Figure 6.16. Each frame carries 1 byte from each channel; the size of each frame, therefore, is 4 bytes, or 32 bits. Because each channel is sending 100 bytes/s and a frame carries 1 byte from each channel, the frame rate must be 100 frames per second. The duration of a frame is therefore $\frac{1}{100} \text{ s}$. The link is carrying 100 frames per second, and since each frame contains 32 bits, the bit rate is 100×32 , or 3200 bps. This is actually 4 times the bit rate of each channel, which is $100 \times 8 = 800 \text{ bps}$.

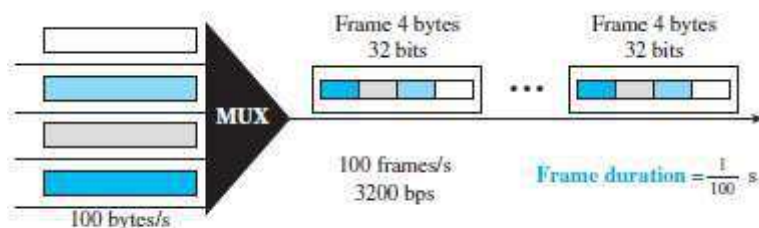

Figure 6.16

Example 2.20

A multiplexer combines four 100-kbps channels using a time slot of 2 bits. Show the output with four arbitrary inputs. What is the frame rate? What is the frame duration? What is the bit rate? What is the bit duration?

Solution

Figure 6.17 shows the output for four arbitrary inputs. The link carries 50,000 frames per second since each frame contains 2 bits per channel. The frame duration is therefore $1/50,000$ s or $20 \mu\text{s}$. The frame rate is 50,000 frames per second, and each frame carries 8 bits; the bit rate is $50,000 \times 8 = 400,000$ bits or 400 kbps. The bit duration is $1/400,000$ s, or $2.5 \mu\text{s}$. Note that the frame duration is 8 times the bit duration because each frame is carrying 8 bits.

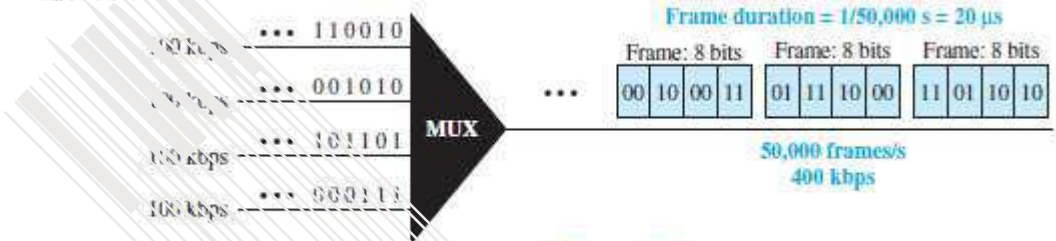

Figure 6.17

2.4.3.1.3 Empty Slots

- Problem: Synchronous TDM is not efficient.

For example: If a source does not have data to send, the corresponding slot in the output-frame is empty.

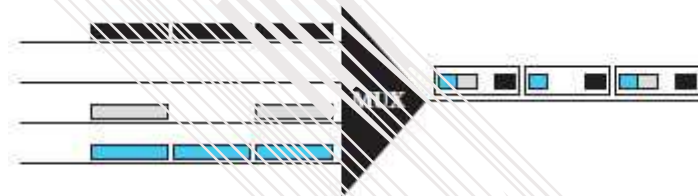

Figure 6.18 Empty slots

- As shown in Figure 6.18,
 - Second input-line has no data to send
 - Third input-line has discontinuous data.
- The first output-frame has 3 slots filled.
 - The second frame has 2 slots filled.
 - The third frame has 3 slots filled.
 - No frame is full.
- Solution: Statistical TDM can improve the efficiency by removing the empty slots from the frame.

DATA COMMUNICATION

2.4.3.1.4 Data Rate Management

- Problem in TDM: How to handle differences in the input data-rates?
- If data-rates are not the same, three strategies can be used.
- Three different strategies: 1) Multilevel multiplexing 2) Multiple-slot allocation and 3) Pulse stuffing

1) Multilevel Multiplexing

- This technique is used when the data-rate of an input-line is a multiple of others.

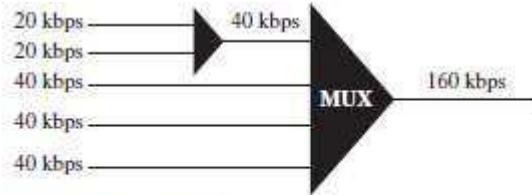

Figure 6.19 Multilevel multiplexing

- For example:
 - As shown in Figure 6.19, we have 2 inputs of 20 kbps and 3 inputs of 40 kbps.
 - The first 2 input-lines can be multiplexed to provide a data-rate of 40 kbps.

2) Multiple Slot Allocation

- Sometimes it is more efficient to allot more than 1 slot in a frame to a single input-line.

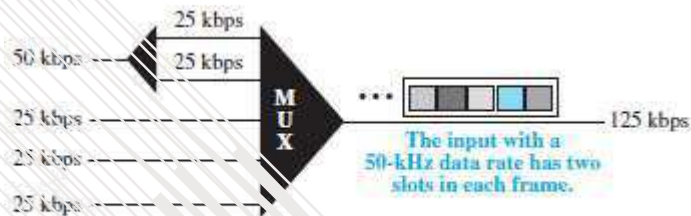

Figure 6.20 Multiple-slot multiplexing

- For example:
 - Data-rate of multiple input-lines can be data-rate of one input-line.
 - As shown in Figure 6.20, the input-line with a 50-kbps data-rate can be given 2 slots in the output-line.
 - In first input line, serial-to-parallel converter is used. The converter creates two 25 kbps input lines out of one 50 kbps input line.

3) Pulse Stuffing

- Sometimes the bit-rates of sources are not multiple integers of each other. ". above 2 techniques cannot be used.
- Solution:
 - Make the highest input data-rate the dominant data-rate. →
 - Then, add dummy bits to the input-lines with lower rates. →
 - This will increase data rates of input-line.
 - This technique is called pulse stuffing, bit padding, or bit stuffing.

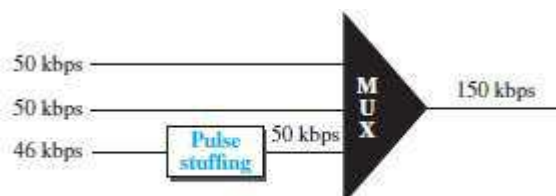

Figure 6.21 Pulse stuffing

- As shown in Figure 6.21, the input-line with a lower data-rate = 46kbps is pulse-stuffed to increase the data-rate to 50 kbps.
- Now, multiplexing can take place.

DATA COMMUNICATION

2.4.3.1.5 Frame Synchronizing

- Problem: Synchronization between the multiplexer and demultiplexer is a major issue.

If the multiplexer and the demultiplexer are not synchronized, a bit belonging to one channel may be received by the wrong channel.

Solution: Usually, one or more synchronization-bits are added to the beginning of each frame. These bits are called *framing-bits*.

The framing-bits follow a pattern (frame-to-frame) that allows multiplexer and demultiplexer to synchronize.

As shown in Figure 6.22, the synchronization-information

- consists of 1 bit per frame and
- alternates between 0 & 1.

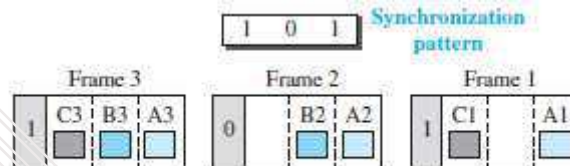

Figure 6.22 Framing bits

Example 2.21

We have four sources, each creating 250 characters per second. If the interleaved unit is a character and 1 synchronizing bit is added to each frame, find (1) the data rate of each source, (2) the duration of each character in each source, (3) the frame rate, (4) the duration of each frame, (5) the number of bits in each frame, and (6) the data rate of the link.

Solution

We can answer the questions as follows:

1. The data rate of each source is $250 \times 8 = 2000 \text{ bps} = 2 \text{ kbps}$.
2. Each source sends 250 characters per second; therefore, the duration of a character is $1/250 \text{ s}$, or 4 ms.
3. Each frame has one character from each source, which means the link needs to send 250 frames per second to keep the transmission rate of each source.
4. The duration of each frame is $1/250 \text{ s}$, or 4 ms. Note that the duration of each frame is the same as the duration of each character coming from each source.
5. Each frame carries 4 characters and 1 extra synchronizing bit. This means that each frame is $4 \times 8 + 1 = 33 \text{ bits}$.
6. The link sends 250 frames per second, and each frame contains 33 bits. This means that the data rate of the link is 250×33 , or 8250 bps. Note that the bit rate of the link is greater than the combined bit rates of the four channels. If we add the bit rates of four channels, we get 8000 bps. Because 250 frames are traveling per second and each contains 1 extra bit for synchronizing, we need to add 250 to the sum to get 8250 bps.

Example 2.22

Two channels, one with a bit rate of 100 kbps and another with a bit rate of 200 kbps, are to be multiplexed. How this can be achieved? What is the frame rate? What is the frame duration? What is the bit rate of the link?

Solution

We can allocate one slot to the first channel and two slots to the second channel. Each frame carries 3 bits. The frame rate is 100,000 frames per second because it carries 1 bit from the first channel. The frame duration is $1/100,000 \text{ s}$, or 10 ms. The bit rate is $100,000 \text{ frames/s} \times 3 \text{ bits per frame}$, or 300 kbps. Note that because each frame carries 1 bit from the first channel, the bit rate for the first channel is preserved. The bit rate for the second channel is also preserved because each frame carries 2 bits from the second channel.

DATA COMMUNICATION

2.4.3.2 Statistical TDM

- Problem: Synchronous TDM is not efficient.
For ex: If a source does not have data to send, the corresponding slot in the output-frame is empty.
Solution: Use statistical TDM.
Slots are dynamically allocated to improve bandwidth-efficiency.
Only when an input-line has data to send, the input-line is given a slot in the output-frame.
- The number of slots in each frame is less than the number of input-lines.
- The multiplexer checks each input-line in round robin fashion.
If the line has data to send;
Then, multiplexer allocates a slot for an input-line;
Otherwise, multiplexer skips the line and checks the next line.

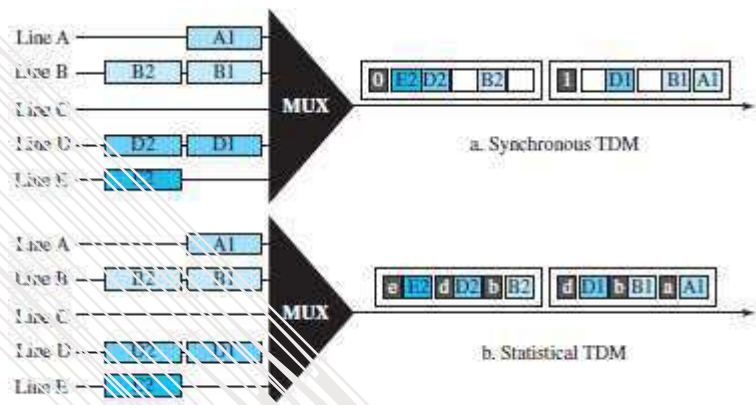

Figure 6.26 TDM slot comparison

- In synchronous TDM (Figure 6.26a), some slots are empty because the corresponding line does not have data to send.
- In statistical TDM (Figure 6.26b), no slot is left empty.

1) Addressing

Synchronous TDM	Statistical TDM
An output-slot needs to carry only data of the destination (Figure 6.26a).	An output-slot needs to carry both data & address of the destination (Figure 6.26b).
There is no need for addressing. Synchronization and pre-assigned relationships between the inputs and outputs serve as an address.	There is no fixed relationship between the inputs and outputs because there are no pre-assigned or reserved slots. We need to include the address of the receiver inside each slot to show where it is to be delivered.

2) Slot Size

- Usually, a block of data is many bytes while the address is just a few bytes. A slot carries both data and address.
- Therefore, address-size must be very small when compared to data-size.
This results in efficient transmission.
- For example:
It will be inefficient to send 1 bit per slot as data, when the address is 3 bits.
This means an overhead of 300%.

3) No Synchronization Bit

- In statistical TDM, the frames need not be synchronized, so synchronization-bits are not needed.

4) Bandwidth

- Normally, the capacity of the link is less than the sum of the capacities of each channel.
- The designers define the capacity of the link based on the statistics of the load for each channel.

DATA COMMUNICATION

2.5 SPREAD SPECTRUM

- Spread-spectrum is used in wireless applications (Figure 6.27).
 - In wireless applications, all stations use air (or a vacuum) as the medium for communication.
 - Goal: Stations must be able to share the air medium without interception by an attacker.
- Solution: Spread-spectrum techniques add redundancy i.e. they spread the original spectrum needed for each station.
- If the required bandwidth for each station is B , spread-spectrum expands it to B_{ss} such that $B_{ss} \gg B$.
 - The expanded-bandwidth allows the source to place its message in a protective envelope for a more secure transmission.

(An analogy is the sending of a delicate, expensive gift. We can insert the gift in a special box to prevent it from being damaged during transportation).

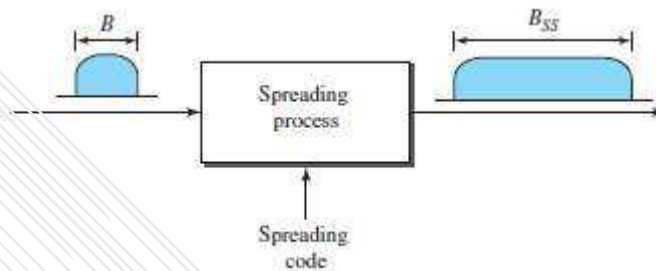

Figure 6.27 Spread spectrum

- Spread-spectrum achieves its goal through 2 principles:
 - 1) The bandwidth allocated to each station needs to be, by far, larger than what is needed. This allows redundancy.
 - 2) The spreading process must occur after the signal is created by the source.
- After the signal is created by the source, the spreading process
 - uses a spreading-code and
 - spreads the bandwidth.
- The spreading-code is a series of numbers that look random, but are actually a pattern.
- Two types of spread-spectrum:
 - 1) Frequency hopping spread-spectrum (FHSS) and
 - 2) Direct sequence spread-spectrum (DSSS).

DATA COMMUNICATION

2.5.1 Frequency Hopping Spread Spectrum (FHSS)

- This technique uses „M“ different carrier-frequencies that are modulated by the source-signal.
- At one moment, the signal modulates one carrier-frequency.
- At the next moment, the signal modulates another carrier-frequency.
- Although the modulation is done using one carrier-frequency at a time, 'M' frequencies are used in the long run.
- The bandwidth occupied by a source is given by

$$B_{FHSS} \gg B$$

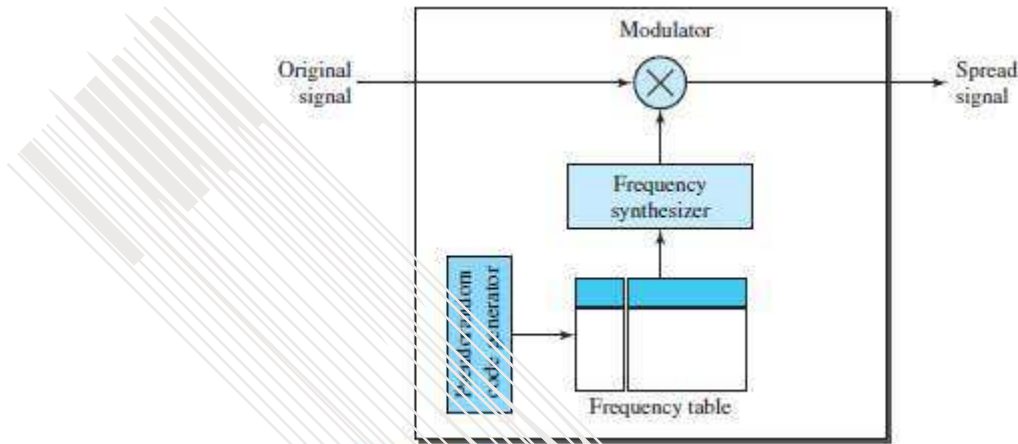

Figure 6.28 Frequency hopping spread spectrum (FHSS)

- As shown in Figure 6.28.
 - A pseudorandom code generator (PN) creates a k-bit pattern for every hopping period T_h .
 - The frequency-table → uses the pattern to find the frequency to be used for this hopping period and → passes the frequency to the frequency-synthesizer.
 - The frequency-synthesizer creates a carrier-signal of that frequency.
 - The source-signal modulates the carrier-signal.

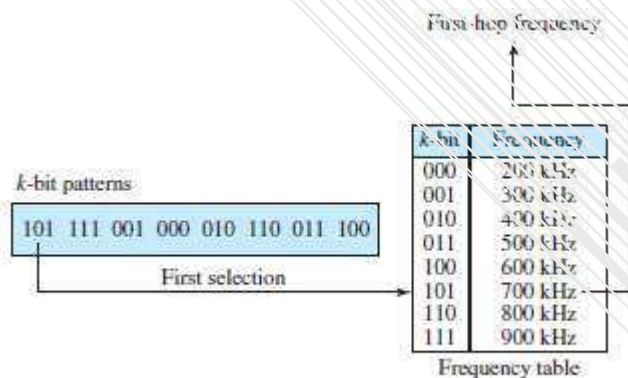

Figure 6.29 Frequency selection in FHSS

- As shown in Figure 6.29, assume we have 8 hopping frequencies.
 - Here, $M = 8$ and $k = 3$.
 - The pseudorandom code generator will create 8 different 3-bit patterns.
 - These are mapped to 8 different frequencies in the frequency table (see Figure 6.29).
- The pattern for this station is 101, 111, 001, 000, 010, 111 & 100.
 - 1) At hopping-period 1, the pattern is 101. The frequency selected is 700 kHz; the source-signal modulates this carrier-frequency.
 - 2) At hopping-period 2, the pattern is 111. The frequency selected is 900 kHz; the source-signal modulates this carrier-frequency.

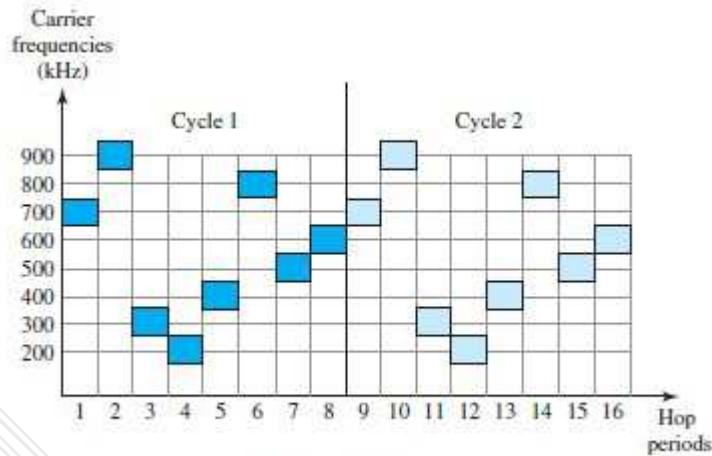

Figure 6.30 FHSS cycles

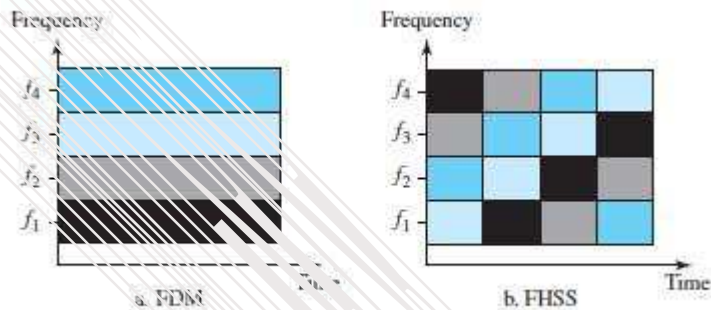

Figure 6.1 Bandwidth sharing

- If there are many k -bit patterns & the hopping period is short, a sender & receiver can have privacy. If an attacker tries to intercept the transmitted signal, he can only access a small piece of data because he does not know the spreading sequence to quickly adapt himself to the next hop.
- The scheme has also an anti-jamming effect. A malicious sender may be able to send noise to jam the signal for one hopping period (randomly), but not for the whole period.

2.5.1.1 Bandwidth Sharing

- If the number of hopping frequencies is M , we can multiplex M channels into one by using the same B_{ss} bandwidth.
- This is possible because
 - 1) A station uses just one frequency in each hopping period.
 - 2) Other $M-1$ stations uses other $M-1$ frequencies.
- In other words, M different stations can use the same B_{ss} if a multiple FSK (MFSK) is used.

DATA COMMUNICATION

2.5.2 Direct Sequence Spread Spectrum (DSSS)

- This technique expands the bandwidth of the original signal.
- Each data-bit is replaced with „n“ bits using a spreading-code.
- Each bit is assigned a code of „n“ bits called chips.
- The chip-rate is „n“ times that of the data-bit (Figure 6.32).

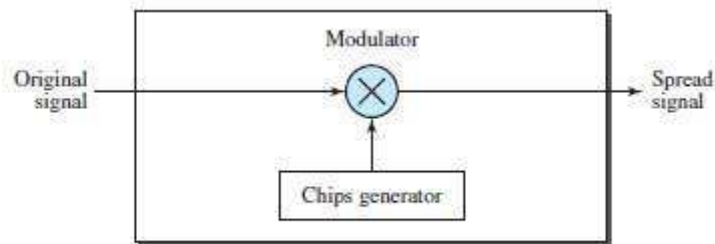

Figure 6.32 DSSS

- For example (Figure 6.33):
 - Consider the Barker sequence used in a wireless LAN. Here $n = 11$.
 - Assume that the original signal and the chips in the chip-generator use polar NRZ encoding. The spreading-code is 11 chips having the pattern 10110111000.
 - If the original signal-rate is N , the rate of the spread signal is $1/N$.
 - This means that the required bandwidth for the spread signal is 11 times larger than the bandwidth of the original signal.

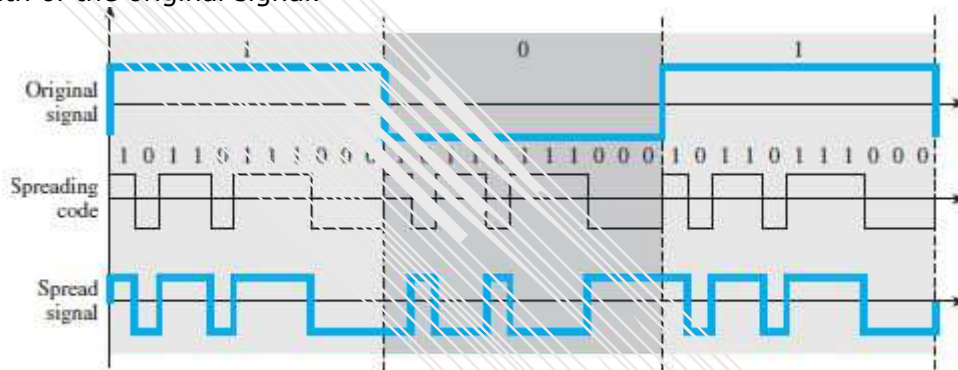

Figure 6.33 DSSS example

- The spread signal can provide privacy if the attacker does not know the code.
- It can also provide immunity against interference if each station uses a different code.

2.5.2.1 Bandwidth Sharing

- Can we share a bandwidth in DSSS?
- The answer is no and yes.
 - 1) If we use a spreading-code that spreads signals that cannot be combined and separated, we cannot share a bandwidth.
 - For example:

Some wireless LANs use DSSS and the spread bandwidth cannot be shared.
 - 2) If we use a special spreading-code that spreads signals that can be combined and separated, we can share a bandwidth.
 - For example:

Cellular telephony uses DSSS and the spread bandwidth is shared b/w several users.

MODULE 2(CONT.): SWITCHING

2.6 SWITCHING

- A network is a set of connected-devices.
- Problem: Whenever we have multiple-devices, we have the problem of how to connect them to make one-to-one communication possible.
- Solution: Use Switching.
- A switched-network consists of a series of interlinked-nodes, called switches.
- Switches are devices capable of creating temporary connections between two or more devices.
- In a switched-network,
 - 1) Some nodes are connected to the end-systems (For example: PC or TP).
 - 2) Some nodes are used only for routing.

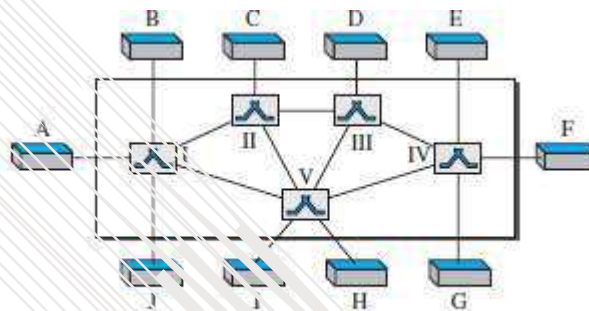

Figure 8.1 Switched network

- As shown in Figure 8.1,
 - 1) The end-systems are labeled A, B, C, D, and so on.
 - 2) The switches are labeled I, II, III, IV, and V. Each switch is connected to multiple links.

2.6.1 Three Methods of Switching

- Three methods of Switching are (Figure 8.2):
 - 1) Circuit Switching
 - 2) Packet Switching and
 - 3) Message Switching.
- The first two are commonly used today.
- The third has been phased out in general communications but still has networking applications.
- Packet switching can further be divided into two subcategories—virtual circuit approach and datagram approach

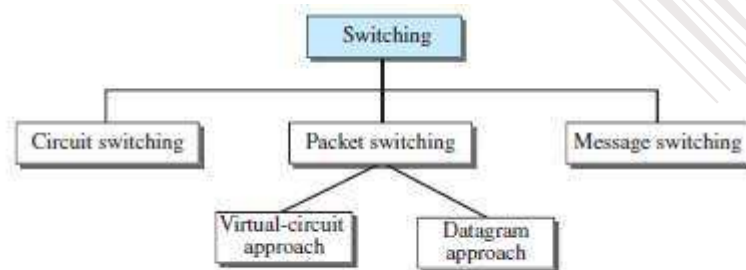

Figure 8.2 Taxonomy of switched networks

DATA COMMUNICATION

2.6.2 Switching and TCP/IP Layers

- Switching can happen at several layers of the TCP/IP protocol suite.
 - 1) Switching at Physical Layer**
 - At the physical layer, we can have only circuit switching.
 - There are no packets exchanged at the physical layer.
 - The switches at the physical layer allow signals to travel in one path or another.
 - 2) Switching at Data-Link Layer**
 - At the data-link layer, we can have packet switching.
 - However, the term packet in this case means frames or cells.
 - Packet switching at the data-link layer is normally done using a virtual-circuit approach.
 - 3) Switching at Network Layer**
 - At the network layer, we can have packet switching.
 - In this case, either a virtual-circuit approach or a datagram approach can be used.
 - Currently the Internet uses a datagram approach, but the tendency is to move to a virtualcircuit approach.
 - 4) Switching at Application Layer**
 - At the application layer, we can have only message switching.
 - The communication at the application layer occurs by exchanging messages.
 - Conceptually, we can say that communication using e-mail is a kind of message-switched communication, but we do not see any network that actually can be called a message-switched network.

DATA COMMUNICATION

2.7 CIRCUIT SWITCHED NETWORK

- This is similar to telephone system.
- Fixed path (connection) is established between a source and a destination prior to the transfer of packets.
- A circuit-switched-network consists of a set of switches connected by physical-links (Figure 8.3).
- A connection between 2 stations is a dedicated-path made of one or more links.
- However, each connection uses only one dedicated-channel on each link.
- Normally, each link is divided into „n“ channels by using FDM or TDM.
- The resources need to be reserved during the setup phase.

The resources remain dedicated for the entire duration of data transfer until the teardown phase.

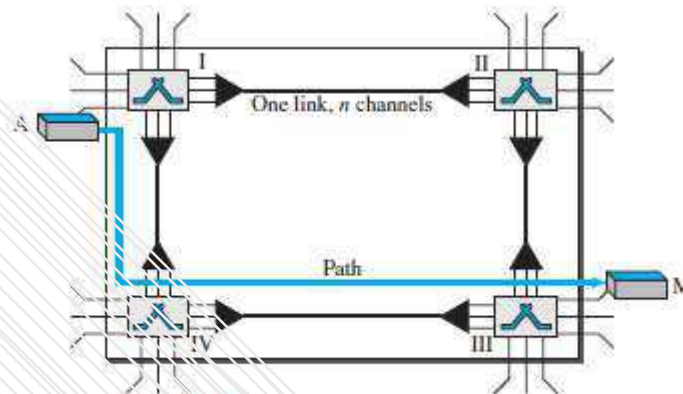

Figure 8.3 A virtual circuit-switched network

- The virtual-circuit setup procedure
 - first determines a path through the network &
 - sets parameters in the switches by exchanging connect-request & connect-confirm messages
- If a switch does not have enough resources to set up a virtual circuit, the switch responds with a connect-reject message and the setup procedure fails (Figure 7.15).
- A connection-release procedure may also be required to terminate the connection.

2.7.1 Three Phases

- The communication requires 3 phases:
 - 1) Connection-setup
 - 2) Data-transfer
 - 3) Connection teardown.

1) Setup Phase

- Before the 2 parties can communicate, a dedicated-circuit needs to be established.
- Normally, the end-systems are connected through dedicated-lines to the switches.
 - So, connection-setup means creating dedicated-channels between the switches.
- For ex: Assume system-A needs to connect to system-M. For this, following events occur:
 - i) System-A sends a setup-request to switch-I.
 - ii) Switch-I finds a channel between itself and switch-IV that can be dedicated for this purpose.
 - iii) Switch-I then sends the request to switch-IV, which finds a dedicated-channel between itself and switch-III.
 - iv) Switch-III informs system-M of system-A's intention at this time.
 - v) Finally, an acknowledgment from system-M needs to be sent in the opposite direction to system-A.
- Only after system A receives this acknowledgment is the connection established.

2) Data Transfer Phase

- After the establishment of the dedicated-circuit (channels), the two parties can transfer data.

3) Teardown Phase

- When one of the parties needs to disconnect, a signal is sent to each switch to release the resources.

DATA COMMUNICATION

2.7.2 Efficiency

- Circuit-switched-networks are inefficient when compared to other two types of networks because
 - 1) Resources are allocated during the entire duration of the connection.
 - 2) These resources are unavailable to other connections.

2.7.3 Delay

- Circuit-switched-networks have minimum delay when compared to other two types of networks
- During data-transfer,
 - 1) The data are not delayed at each switch.
 - 2) The resources are allocated for the duration of the connection.

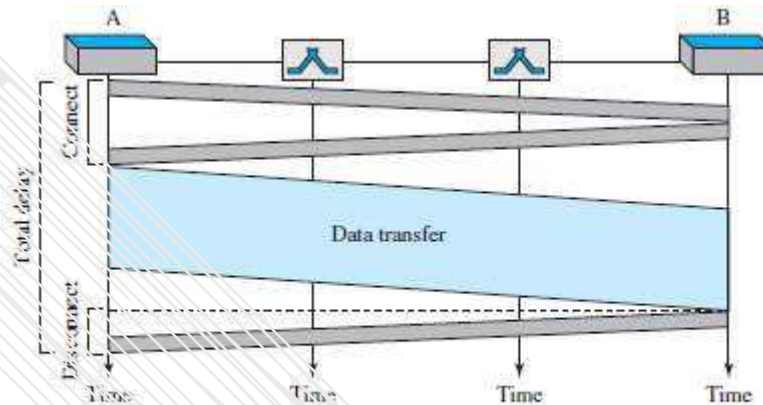

Figure 2.6 Delay in a circuit-switched network

- As in the above figure, there is no waiting time at each switch. • The total delay is the time needed to
 - 1) Create the connection
 - 2) Transfer-data and
 - 3) Disconnect the circuit.
- The delay caused by the setup is the sum of 4 parts:
 - 1) The propagation time of the source-computer request.
 - 2) The request signal transfer time.
 - 3) The propagation time of the acknowledgment from the destination computer.
 - 4) The signal transfer time of the acknowledgment.
- The delay due to data-transfer is the sum of 2 parts:
 - 1) The propagation time.
 - 2) Data-transfer time which can be very long.

DATA COMMUNICATION

2.8 PACKET SWITCHED NETWORK

- The message is divided into packets of fixed or variable size.
- The packet-size is determined by
 - network and
 - governing protocol.
- There is no resource reservation; resources are allocated on-demand.

2.8.1 Datagram Networks

- This is analogous to postal system.
- Each packet is routed independently through the network.
- Each packet has a header that contains source and destination addresses.
- Each switch examines the header to determine the next hop in the path to the destination.
- If the transmission line is busy then the packet is placed in the queue until the line becomes free.
- Packets are referred to as datagrams.
- Datagram switching is normally done at the network layer.
- In Internet, switching is done by using the datagram switching.
- Advantage:
 - 1) High utilization of transmission-line can be achieved by sharing among multiple packets.
- Disadvantages:
 - 1) Packets may arrive out-of-order, and re-sequencing may be required at the destination
 - 2) Loss of packets may occur when a switch has insufficient buffer

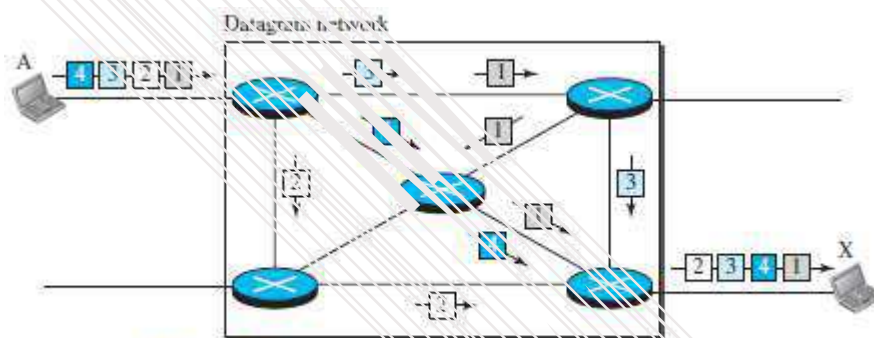

Figure 8.7 A datagram network with four switches (routers)

- The Figure 8.7 shows how the 4 packets are transferred from station-A to station-X. •
- The switches are referred to as routers.
- All four packets (or datagrams) belong to the same message, but may travel different paths to reach their destination.
- This is so because the links may be involved in carrying packets from other sources and do not have the necessary bandwidth available to carry all the packets from A to X.
- This approach can cause the datagrams of a transmission to arrive at their destination out-of-order with different delays between the packets.
- Packets may also be lost or dropped because of a lack-of-resources. •
- It is the responsibility of an upper-layer protocol to
 - reorder the datagrams or
 - ask for lost datagrams.
- The datagram-networks are referred to as connectionless networks. This is because
 - 1) The switch does not keep information about the connection state.
 - 2) There are no setup or teardown phases.
 - 3) Each packet is treated the same by a switch regardless of its source or destination.

DATA COMMUNICATION

2.8.1.1 Routing Table

- Each switch has a routing-table which is based on the destination-address.
- The routing-tables are dynamic & updated periodically.
- The destination-addresses and the corresponding forwarding output-ports are recorded in the tables.

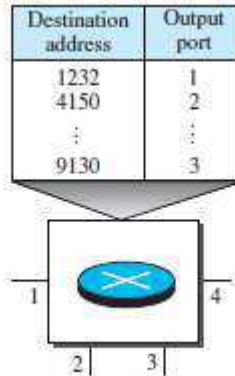

Figure 8.8 Routing table in a datagram network

2.8.1.1.1 Destination Address

- Every packet carries a header that contains the destination-address of the packet.
- When the switch receives the packet,
 - This destination-address is examined.
 - The routing-table is consulted to find the corresponding port through which the packet should be forwarded.
- The destination address in the header of a packet remains the same during the entire journey of the packet.

2.8.1.1.2 Efficiency

- Datagram-networks are more efficient when compared to circuit-switched-network. This is because
 - 1) Resources are allocated only when there are packets to be transferred.
 - 2) If a source sends a packet and there is a delay of a few minutes before another packet can be sent, the resources can be re-allocated during these minutes for other packets from other sources.

2.8.1.1.3 Delay

- Datagram-networks may have greater delay when compared to circuit-switched-network. This is because
 - 1) Each packet may experience a wait at a switch before it is forwarded.
 - 2) Since not all packets in a message necessarily travel through the same switches, the delay is not uniform for the packets of a message.

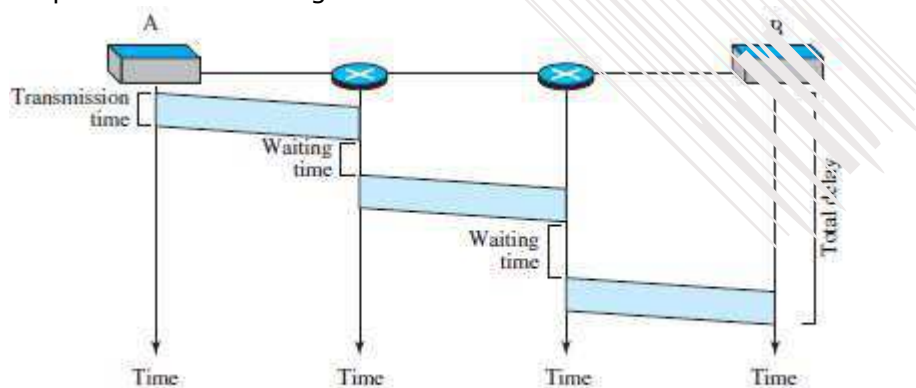

Figure 8.9 Delay in a datagram network

- The Figure 8.9 gives an example of delay for one single packet. The packet travels through two switches.
- There are three transmission times ($3T$), three propagation delays (slopes $3t$ of the lines), and two waiting times ($W_1 + W_2$).

$$\text{Total delay} = 3T + 3t + w_1 + w_2$$

DATA COMMUNICATION

2.8.2 Virtual Circuit Network (VCN)

- This is similar to telephone system.
- A virtual-circuit network is a combination of circuit-switched-network and datagram-network.
- Five characteristics of VCN:
 - 1) As in a circuit-switched-network, there are setup & teardown phases in addition to the data transfer phase.
 - 2) As in a circuit-switched-network, resources can be allocated during the setup phase.
As in a datagram-network, resources can also be allocated on-demand.
 - 3) As in a datagram-network, data is divided into packets.
Each packet carries an address in the header.
However, the address in the header has local jurisdiction, not end-to-end jurisdiction.
 - 4) As in a circuit-switched-network, all packets follow the same path established during the connection.
 - 5) A virtual-circuit network is implemented in the data link layer.
A circuit-switched-network is implemented in the physical layer.
A datagram-network is implemented in the network layer.

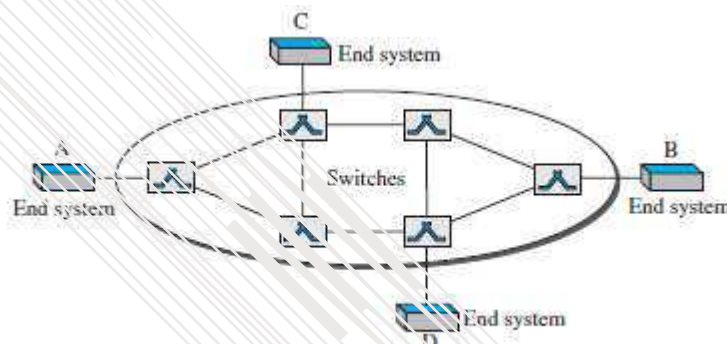

Figure 8.10 Virtual-circuit network

- The Figure 8.10 is an example of a virtual-circuit network.
- The network has switches that allow traffic from sources to destinations.
- A source or destination can be a computer, packet switch, bridge, or any other device that connects other networks.

2.8.2.1 Addressing

- Two types of addressing: 1) Global and 2) Local (virtual-circuit identifier).

1) Global Addressing

- A source or a destination needs to have a global address.
- Global address is an address that can be unique in the scope of the network or internationally if the network is part of an international network.

2) Virtual Circuit Identifier

- The identifier used for data-transfer is called the virtual-circuit identifier (VCI).
A VCI, unlike a global address, is a small number that has only switch scope.
- VCI is used by a frame between two switches.
- When a frame arrives at a switch, it has a VCI.
When the frame leaves, it has a different VCI.

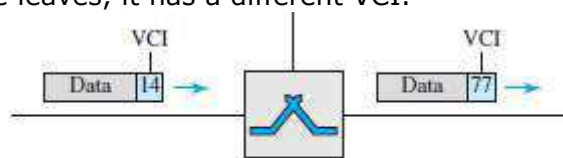

Figure 8.11 Virtual-circuit identifier

- Figure 8.11 show how the VCI in a data-frame changes from one switch to another.

DATA COMMUNICATION

2.8.2.2 Three Phases

- A source and destination need to go through 3 phases: setup, data-transfer, and teardown.
 - 1) In setup phase, the source and destination use their global addresses to help switches make table entries for the connection.
 - 2) In the teardown phase, the source and destination inform the switches to delete the corresponding entry.
 - 3) Data-transfer occurs between these 2 phases.

2.8.2.2.1 Data Transfer Phase

- To transfer a frame from a source to its destination, all switches need to have a table-entry for this virtual-circuit.
- The table has four columns.
- The switch holds 4 pieces of information for each virtual-circuit that is already set up.

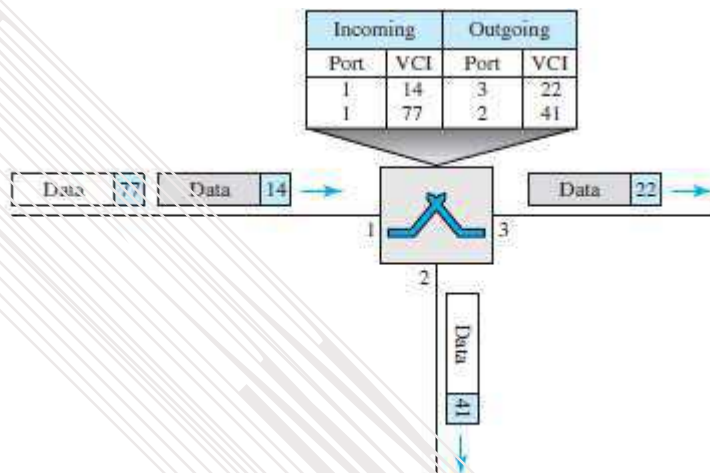

Figure 8.12 Switch and tables in a virtual-circuit network

- As shown in Figure 8.12, a frame arrives at port 1 with a VCI of 14.
- When the frame arrives, the switch looks in its table to find port 1 and a VCI of 14.
- When it is found, the switch knows to change the VCI to 22 & send out the frame from port 3.

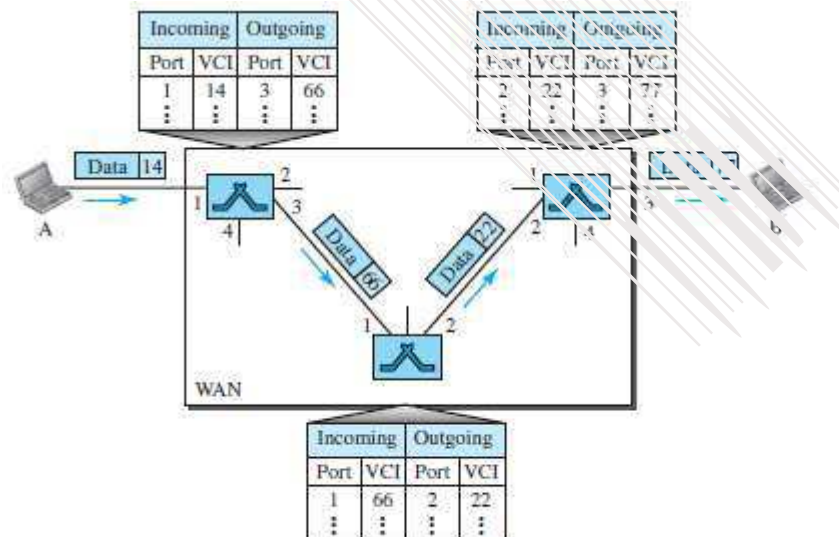

Figure 8.13 Source-to-destination data transfer in a virtual-circuit network

- As shown in Figure 8.13, each switch changes the VCI and routes the frame.
- The data-transfer phase is active until the source sends all its frames to the destination.
- The procedure at the switch is the same for each frame of a message.
- The process creates a virtual circuit, not a real circuit, between the source and destination.

DATA COMMUNICATION

2.8.2.2.2 Setup Phase

- A switch creates an entry for a virtual-circuit.
- For example, suppose source A needs to create a virtual-circuit to B.
- Two steps are required: 1) Setup-request and 2) Acknowledgment.

1) Setup Request

- A setup-request frame is sent from the source to the destination (Figure 8.14).

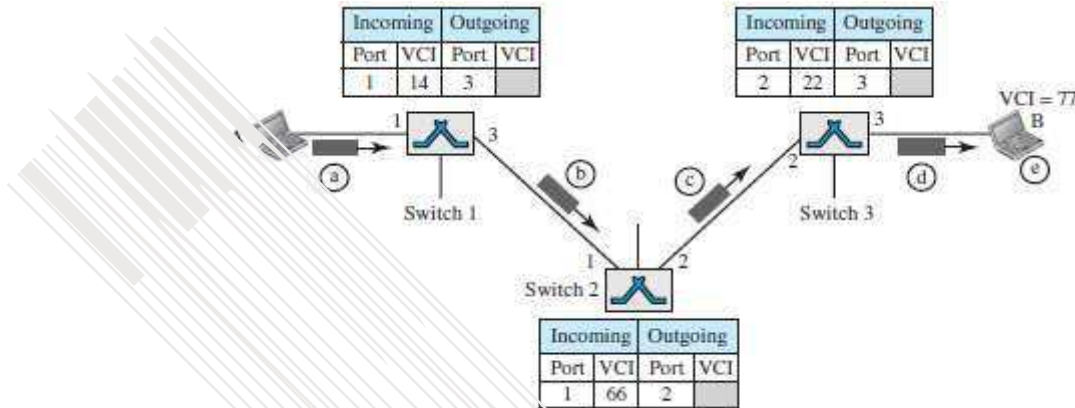

Figure 8.14 Setup request in a virtual-circuit network

- Following events occurs:

a) Source-A sends a setup-frame to switch-1.

b) Switch-1 receives the setup-frame.

- ✕ Switch-1 knows that a frame going from A to B goes out through port 3. ✕ The switch-1 has a routing table.
- ✕ The switch

- creates an entry in its table for this virtual-circuit
- is only able to fill 3 of the 4 columns.

✕ The switch

- assigns the incoming port (1) and
- chooses an available incoming-VCI (14) and the outgoing-port (3). → does not yet know the outgoing VCI, which will be found during the acknowledgment step.

✕ The switch then forwards the frame through port-3 to switch-2.

c) Switch-2 receives the setup-request frame.

✕ The same events happen here as at switch-1.

✕ Three columns of the table are completed: In this case, incoming port (1), incoming-VCI (66), and outgoing port (2).

d) Switch-3 receives the setup-request frame.

✕ Again, three columns are completed: incoming port (2), incoming-VCI (22), and outgoing-port (3).

e) Destination-B

→ receives the setup-frame

→ assigns a VCI to the incoming frames that come from A, in this case 77.

✕ This VCI lets the destination know that the frames come from A, and no other sources.

DATA COMMUNICATION

2) Acknowledgment

- A special frame, called the acknowledgment-frame, completes the entries in the switching tables (Figure 8.15).

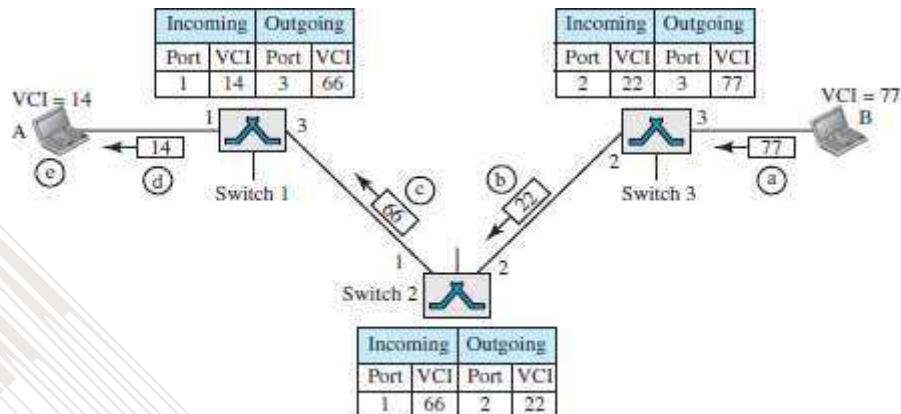

Figure 8.15 Setup acknowledgment in a virtual-circuit network

- The destination sends an acknowledgment to switch-3.
 - ✕ The acknowledgment carries the global source and destination-addresses so the switch knows which entry in the table is to be completed.
 - ✕ The frame also carries VCI 77, chosen by the destination as the incoming-VCI for frames from A.
 - ✕ Switch 3 uses this VCI to complete the outgoing VCI column for this entry.
- Switch 3 sends an acknowledgment to switch-2 that contains its incoming-VCI in the table, chosen in the previous step.
 - ✕ Switch-2 uses this as the outgoing VCI in the table.
- Switch-2 sends an acknowledgment to switch-1 that contains its incoming-VCI in the table, chosen in the previous step.
 - ✕ Switch-1 uses this as the outgoing VCI in the table.
- Finally switch-1 sends an acknowledgment to source-A that contains its incoming-VCI in the table, chosen in the previous step.
- The source uses this as the outgoing VCI for the data-frames to be sent to destination-B.

2.8.2.3 Teardown Phase

- Source-A, after sending all frames to B, sends a special frame called a teardown request.
- Destination-B responds with a teardown confirmation frame.
- All switches delete the corresponding entry from their tables.

2.8.2.4 Efficiency

- Resource reservation can be made in 2 cases:
 - 1) During the setup: Here, the delay for each packet is the same.
 - 2) On demand: Here, each packet may encounter different delays.
- Advantage of on demand resource allocation:

The source can check the availability of the resources, without actually reserving it.

2.8.2.5 Delay in Virtual Circuit Networks

- There is a one-time delay for setup and a one-time delay for teardown (Figure 8.16).
- If resources are allocated during the setup phase, there is no wait time for individual packets.
- The packet is traveling through two switches (routers).
- There are three transmission times ($3T$), three propagation times (3τ), data transfer delay, a setup delay and a teardown delay.
- The total delay time is

$$\text{Total delay} + 3T + 3\tau + \text{setup delay} + \text{teardown delay}$$

DATA COMMUNICATION

Circuit Switching	Datagram Packet Switching	Virtual circuit Packet switching
Dedicate transmission path	No dedicate path	No dedicate path
Continuous transmission of data	Transmission of packets	Transmission of packets
Fast enough for interactive	Fast enough for interactive	Fast enough for interactive
Message are not stored	Packets may be stored until delivered	Packets stored until delivered
The path is established for entire conversation	Route established for each packet	Route established for entire conversation
Call setup delay; negligible transmission delay	Packet transmission delay	Call setup delay; Packet transmission delay
Busy signal if called party busy	Sender may be notified if packet not delivered	Sender notified of connection denial
Overload may block call setup; no delay for established calls	Overload increases packet delay	Overload may block call setup; increases packet delay
Electromechanical or computerized switching nodes	Small switching nodes	Small switching nodes
User responsible for message loss protection	Network may be responsible for individual packets	Network may be responsible for packet sequences
Usually no speed or code conversion	Speed and code conversion	Speed and code conversion
Fixed bandwidth	Dynamic use of bandwidth	Dynamic use of bandwidth
No overhead bits after call setup	Overhead bits in each packet	Overhead bits in each packet

MODULE-WISE QUESTIONS

MODULE 2: DIGITAL TRANSMISSION (CONT.)

- 1) Explain the PCM encoder with neat diagram. (8*)
- 2) What do you mean by Sampling? Explain three sampling methods with a neat diagram. (4)
- 3) Explain non-uniform quantization and how to recover original signal using PCM decoder. (4)
- 4) Explain different types of transmission modes. (8*)
- 5) What is sampling and quantization? Explain briefly. (6)

MODULE 2(CONT.): ANALOG TRANSMISSION

- 1) Define digital to analog conversion? List different types of digital to analog conversion. (2)
- 2) Describe ASK, FSK and PSK mechanisms and apply them over the digital data 101101. (4)
- 3) Discuss the bandwidth requirement for ASK, FSK and PSK. (4*)
- 4) Explain different aspects of digital-to-analog conversion? (6*)
- 5) Define ASK. Explain BASK. (6*)
- 6) Define FSK. Explain BFSK. (6*)
- 7) Define PSK. Explain BPSK. (6*)
- 8) Explain QPSK. (6)
- 9) Explain the concept of constellation diagram. (6)
- 10) Explain QAM. (6)

MODULE 2(CONT.): BANDWIDTH UTILIZATION -- MULTIPLEXING AND SPREADING

- 1) Explain the concepts of multiplexing and list the categories of multiplexing? (4)
- 2) Define FDM? Explain the FDM multiplexing and demultiplexing process with neat diagrams. (6*)
- 3) Define and explain the concept of WDM. (6*)
- 4) Explain in detail synchronous TDM. (6*)
- 5) What do you mean by interleaving? Explain (4)
- 6) Explain Data Rate Management in Multi-level Multiplexing. (4*)
- 7) Explain the concept of empty-slots and frame-synchronizing in Multi-level Multiplexing. (6)
- 8) Explain in detail Statistical TDM. (6*)
- 9) Define FHSS and explain how it achieves bandwidth multiplexing. (8*)
- 10) Define DSSS and explain how it achieves bandwidth multiplexing. (8*)
- 11) Explain the analog hierarchy used by the telephone companies. (6)

MODULE 2(CONT.): SWITCHING

- 1) Explain in detail circuit-switched-network. (6*)
- 2) Explain switching with reference to TCP/IP Layers. (4)
- 3) Explain in detail datagram networks (8*)
- 4) What is Virtual-circuit Network? List five characteristics of VCN. (6*)
- 5) With relevant diagrams, explain the data transfer phase in a virtual circuit network. (8*)
- 6) Explain in detail setup Phase in VCN. (6)
- 7) Explain in detail acknowledgment Phase in VCN. (6)
- 8) Compare circuit-switched-network, Datagram & Virtual-circuit. (5*)