

MODULE 2

MODULE STRUCTURE

2.1 Microwave Network theory: Symmetrical Z and Y-Parameters for Reciprocal Networks

2.2 Objective

2.3 S matrix representation of Multi-Port Networks.

2.4 Microwave Passive Devices: Coaxial Connectors and Adapters

2.5 Attenuators.

2.6 Phase Shifters

2.7 Waveguide Tees

2.8 Magic tees.

2.1 Microwave Network theory: Symmetrical Z and Y-Parameters for Reciprocal Networks

A microwave network consists of coupling of various microwave components and devices such as attenuators, phase shifters, amplifiers, resonators etc., to sources through transmission lines or waveguides. Connection of two or more microwave devices and components to a single point results in a microwave junction. In a low frequency network, the input and output variables are voltage and current which can be related in terms of impedance Z-parameters, or admittance Y-parameters or hybrid h-parameters or ABCD parameters. These relationships for a two-port network of figure 2.1 can be represented by

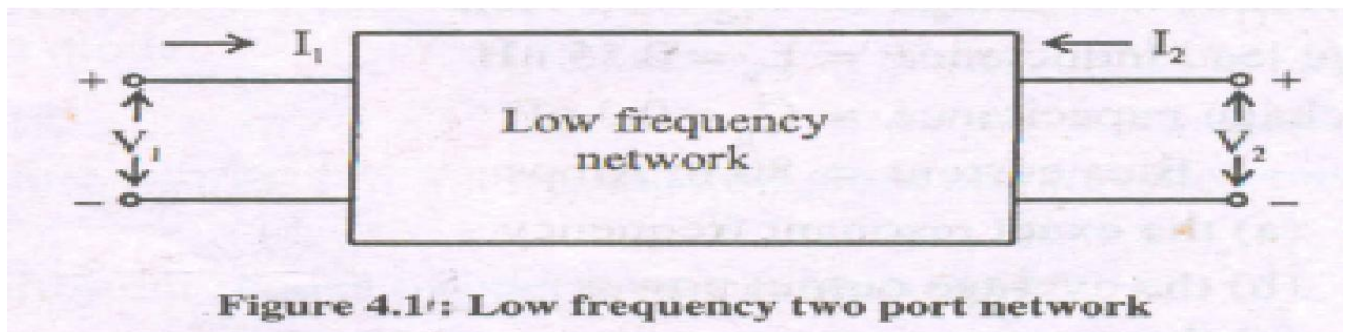

$$\left. \begin{aligned} V_1 &= Z_{11} I_1 + Z_{12} I_2 \\ V_2 &= Z_{21} I_1 + Z_{22} I_2 \end{aligned} \right\} \text{..... (4.1)}$$

or

$$\begin{bmatrix} V_1 \\ V_2 \end{bmatrix} = \begin{bmatrix} Z_{11} & Z_{12} \\ Z_{21} & Z_{22} \end{bmatrix} \begin{bmatrix} I_1 \\ I_2 \end{bmatrix} \text{..... (4.2)}$$

$$\left. \begin{aligned} I_1 &= Y_{11} V_1 + Y_{12} V_2 \\ I_2 &= Y_{21} V_1 + Y_{22} V_2 \end{aligned} \right\} \text{..... (4.3)}$$

or

$$\begin{bmatrix} I_1 \\ I_2 \end{bmatrix} = \begin{bmatrix} Y_{11} & Y_{12} \\ Y_{21} & Y_{22} \end{bmatrix} \begin{bmatrix} V_1 \\ V_2 \end{bmatrix} \text{..... (4.4)}$$

$$\left. \begin{aligned} V_1 &= h_{11} I_1 + h_{12} V_2 \\ I_2 &= h_{21} I_1 + h_{22} V_2 \end{aligned} \right\} \text{..... (4.5)}$$

$$\text{or } \begin{bmatrix} V_1 \\ I_2 \end{bmatrix} = \begin{bmatrix} h_{11} & h_{12} \\ h_{21} & h_{22} \end{bmatrix} \begin{bmatrix} I_1 \\ V_2 \end{bmatrix} \quad \dots (4.6)$$

$$\left. \begin{aligned} V_1 &= AV_2 - BI_2 \\ I_1 &= CV_2 - DI_2 \end{aligned} \right\} \quad \dots (4.7)$$

$$\text{or } \begin{bmatrix} V_1 \\ I_1 \end{bmatrix} = \begin{bmatrix} A & -B \\ C & -D \end{bmatrix} \begin{bmatrix} V_2 \\ I_2 \end{bmatrix} \quad \dots (4.8)$$

These parameters, Z, Y, h and ABeD parameters can be easily measured at low frequencies under short or open circuit conditions and can be used for analyzing the circuit. The physical length of the device or the line at microwave frequencies, is comparable to or much larger than the wavelength. Due to this, the voltage and current are difficult to measure as also the above mentioned parameters. The reasons for this are listed as below. (a) Equipment is not available to measure the total voltage and total current at any point.

(b) Over a wide range of frequencies, short and open circuits are difficult to realize.

(c) Active devices such as power transistors, tunnel diodes etc, will become unstable under short or open circuit conditions.

Therefore, a new representation is needed to overcome these problems at microwave frequencies. The logical variables are traveling waves rather than voltages and currents and these variables are labeled as "Scattering or S-parameters". These parameters for a two port network are represented as shown in Figure 4.2 .

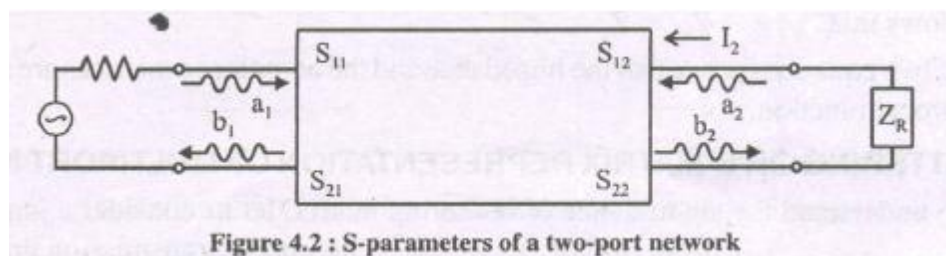

Figure 4.2 : S-parameters of a two-port network

These S-parameters can be represented in an equation form related to the traveling waves a_1, a_2 and b_1, b_2 through

$$\left. \begin{aligned} b_1 &= S_{11} a_1 + S_{12} a_2 \\ b_2 &= S_{21} a_1 + S_{22} a_2 \end{aligned} \right\} \quad \dots (4.9)$$

2.2 Objective

This chapter enables student's to learn S- parameters and different types of connectors.

2.3 S-MATRIX REPRESENTATION OF MULTIPOINT NETWORK

In a reciprocal network, the junction media are characterized by scalar electrical parameters namely absolute permeability and absolute permittivity ϵ . In such a network, the impedance and the admittance matrices become symmetrical. This property can be proved by considering an N-port network. Let E_j and H_j be the respective electric and magnetic field intensities at the j th port and let the total voltage $V = 0$ at all ports for $n = 0, 1, 2, \dots$ Except at i th port. Similarly if E_i and H_i are considered for the i th port with $V = 0$ at other ports, then from reciprocity theorem. Let us now consider a junction of "n" number of rectangular waveguides as shown in figure 2.1. In this case, all "a" s represent the incident waves at respective ports and all "b" s the reflected waves from the microwave junction coming out of the respective ports. In this case also, are still valid where S_{ii} and S_{ij} have the following meanings: S_{ii} = Scattering coefficient corresponding to the input power applied at i th port and output power coming out of i th port and S_{ij} = Scattering coefficient corresponding to the power applied at the i th port and output taken out of j th port itself. This coefficient is a measure of amount of mismatch between the i th port and the junction.

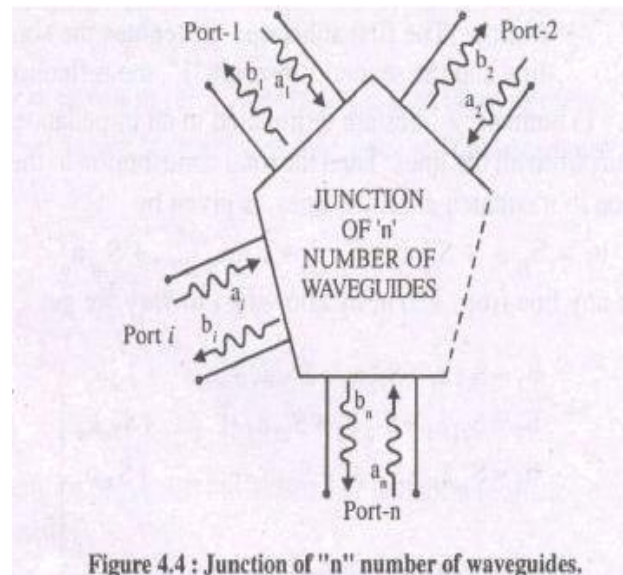

Figure 2.1: Rectangular Waveguide

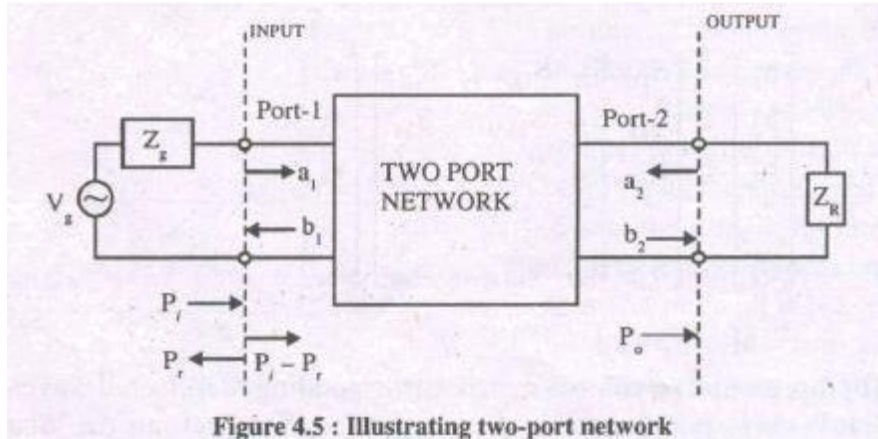

Figure 4.5 : Illustrating two-port network

The relationship between the incident and reflected waves in terms of scattering coefficients can be written as.

$$b_1 = S_{11} a_1 + S_{12} a_2 \quad \dots (4.20)$$

$$b_2 = S_{21} a_1 + S_{22} a_2 \quad \dots (4.21)$$

From these equations, the scattering coefficients are found as

$$S_{11} = \left. \frac{b_1}{a_1} \right|_{a_2=0} = \text{reflection coefficient at port-1 when port-2 is terminated with a matched load } (a_2 = 0)$$

$$S_{22} = \left. \frac{b_2}{a_2} \right|_{a_1=0} = \text{reflection coefficient at port-2 when port-1 is terminated with a matched load } (a_1 = 0)$$

$$S_{12} = \left. \frac{b_1}{a_2} \right|_{a_1=0} = \text{attenuation of the wave travelling from port-2 to port-1.}$$

$$S_{21} = \left. \frac{b_2}{a_1} \right|_{a_2=0} = \text{attenuation of the wave travelling from port-1 to port-2.}$$

In figure 4.5, we have

- P_i = incident power at port-1
- P_r = power reflected by the network coming out of port-1 itself.
- P_o = output power at port-2.

The various losses can be expressed in terms of S-parameters as given below:

$$\text{Insertion loss in dB} = 10 \log_{10} \frac{P_i}{P_o} \quad \dots (4.22)$$

But

$$P_i \propto |a_1|^2$$

$$P_o \propto |b_2|^2$$

$$\therefore \frac{P_i}{P_o} = \frac{|a_1|^2}{|b_2|^2} = \frac{1}{|b_2/a_1|^2} = \frac{1}{|S_{21}|^2} = \frac{1}{|S_{12}|^2} \quad \dots (4.23)$$

2.4 CO-AXIAL CABLES, CONNECTORS AND ADAPTERS

Coaxial Cables Microwave components and devices are interconnected using these co-axial cables of suitable length and operated at microwave frequencies. In this section let us consider some practical aspects of these co-axial cables. TEM mode is propagated through the co-axial line and the outer conductor guides these signals in the dielectric space between itself and inner conductor.

The outer conductor also acts as a shield to prevent the external signals to interfere with the internal signal. It also prevents the internal signal leakage. The co-axial cables usually possess characteristic impedance of either 50 ohms or 75 ohms Based on the structure of shielding, coaxial cables are classified into three basic types.

- (i) Flexible co-axial Cable: Figure below shows the structure of flexible-type of co-axial cable consisting of low loss solid or foam type polyethylene dielectric. Electromagnetic shielding is provided for outer single braid or double braid of the flexible cable as shown, by using knitted metal wire mesh. The centre conductor usually consists of multi strand wire.

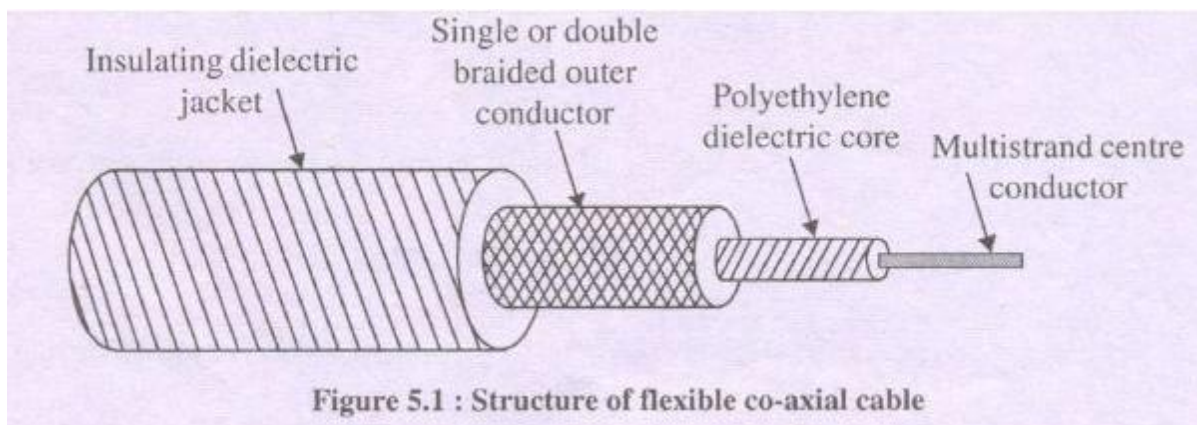

1. Semi-rigid co-axial cable: Figure 5.2 shows the cross-sectional view of semi-rigid co-axial cable. Semi rigid co-axial cables make use of thin outer conductor made of copper and a strong inner conductor also made of copper. The region between the inner and outer conductor contains a solid dielectric. These cables can bent for convenient routing and are not as flexible as the first type.

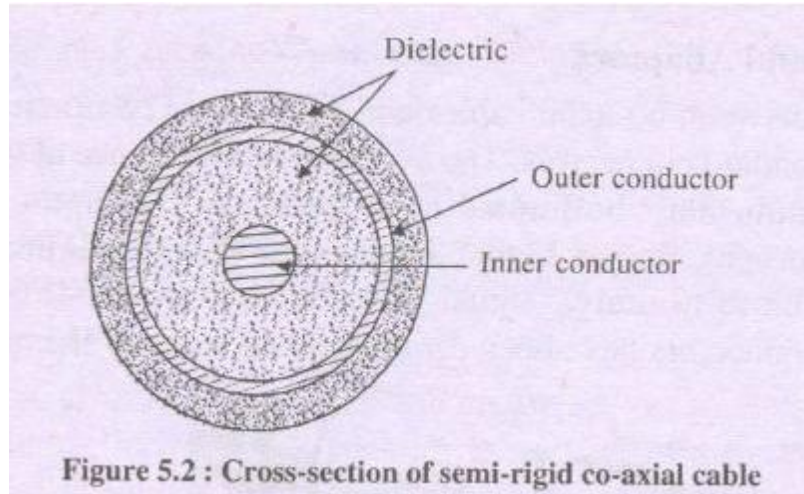

Rigid co-axial cable: Figure below shows the structure of a rigid co-axial cable consisting of inner and outer conductor with air as dielectric. To support the inner conductor at the centre dielectric spacers are introduced at regular intervals as shown. The thickness of these dielectric spacers is made small so that they do not produce significant discontinuities to the wave propagation.

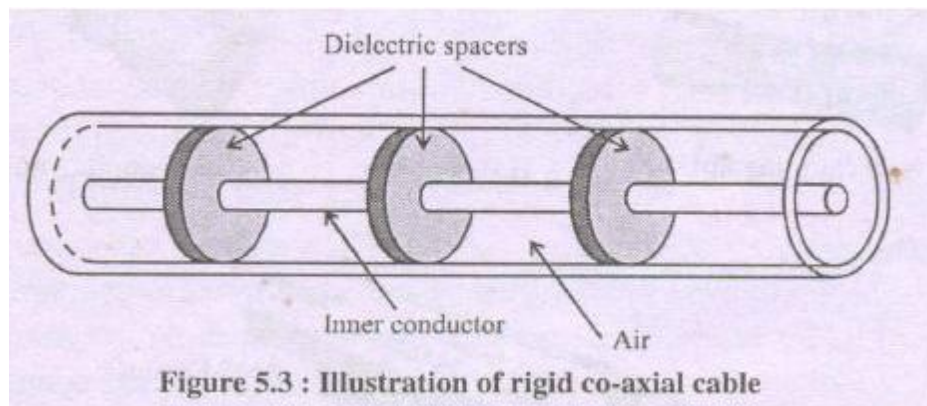

Co-axial cables can be used up to microwave -range of frequencies. Beyond these frequencies attenuation becomes very large (since attenuation increases with frequency) which makes co-axial cables unsuitable at higher frequencies. Some characteristics of standard coaxial cables with their radio guide (RG) and universal (U) numbers along with conductor (inner and outer) dimensions.

Interconnection between co-axial cables and microwave components is achieved with the help of shielded standard connectors. The average circumference of the co-axial cable, for mar high frequency operation must be limited to about one wavelength. This requirement is a VI necessary to reduce propagation at higher modes and also to eliminate erratic reflection coefficients (VSWR close to unity), signal distortion and power losses. Several types of co-axial connectors have been developed and some of them are described below.

(a) APC 3.5 (Amphenol Precision Connector - 3.5 mm)

HP (Hewlett - Packard) originally developed this connector, but it is now being manufactured by Amphenol. This connector can operate up to a frequency of 34 GHz and has a very low voltage standing wave ratio (VSWR). This connector provides repeatable connections and has 50 Ω characteristic impedance. The male connector. it introduces higher order modes and hence not used above 24 GHz.

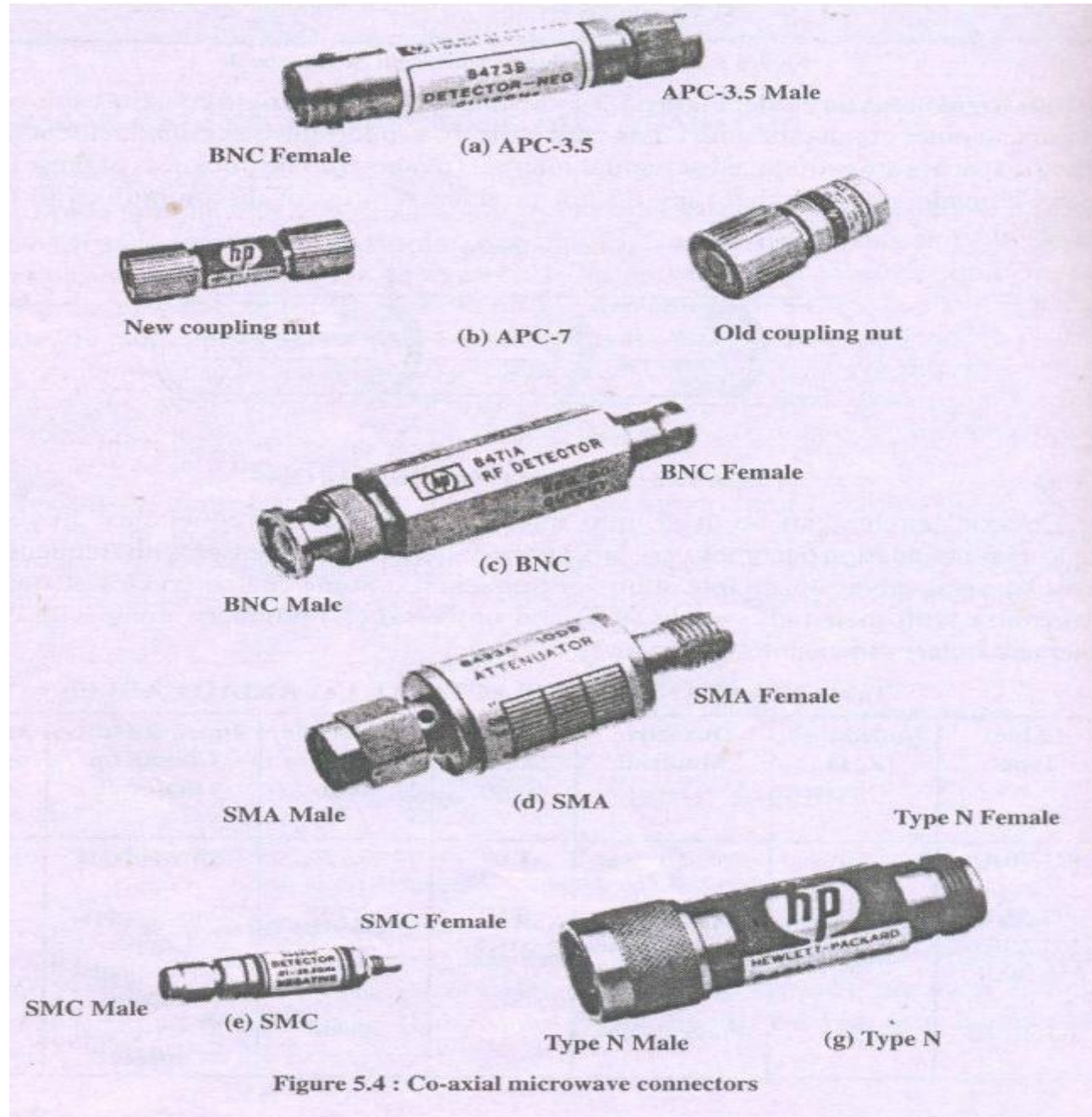

2.5 ATTENUATORS

In order to control power levels in a microwave system by partially absorbing the transmitted microwave signal, attenuators are employed. Resistive films (dielectric glass slab coated with aquatic) are used in the design of both fixed and variable attenuators. A co-axial fixed attenuator uses the dielectric loss material inside the center conductor of the co-axial line to absorb some of the center conductor microwave power propagating through it dielectric rod decides the amount of attenuation introduced. The microwave power absorbed by the lossy material is dissipated as heat.

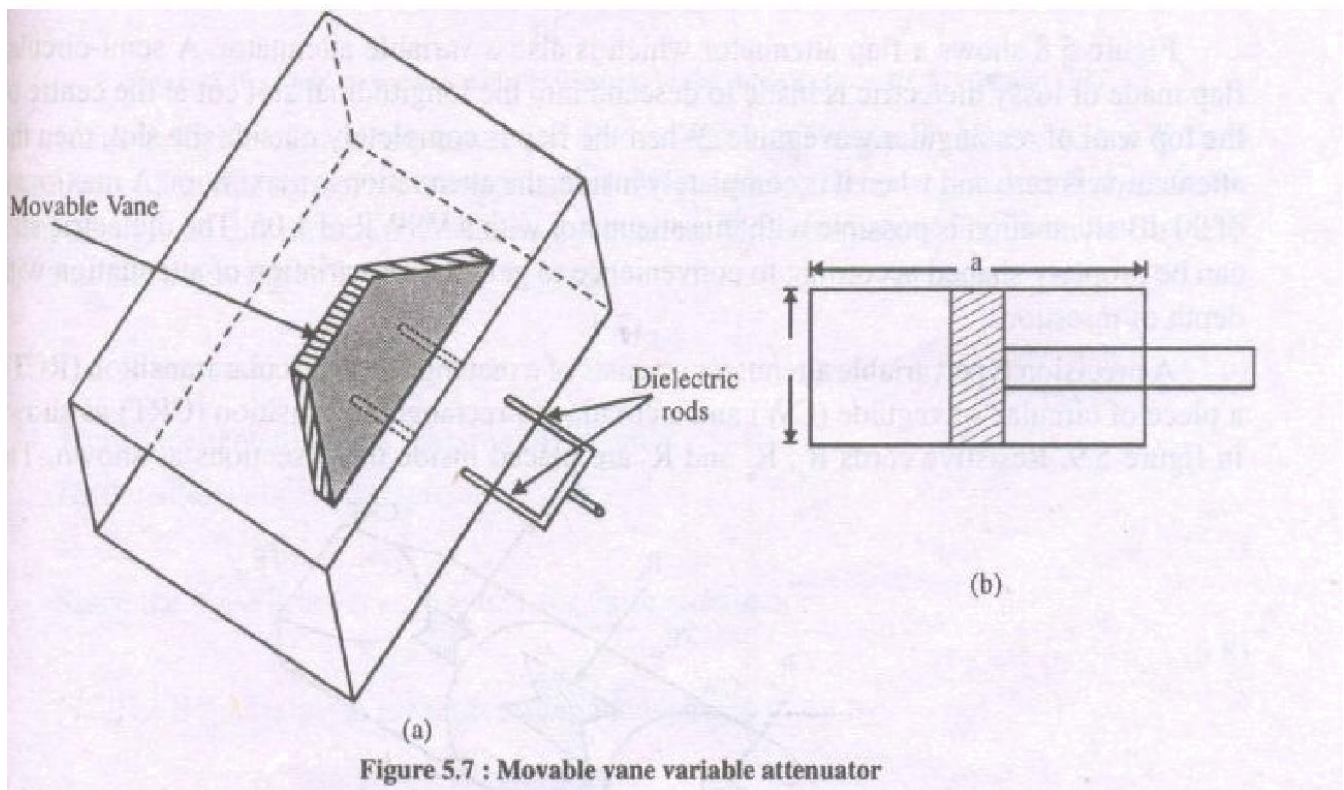
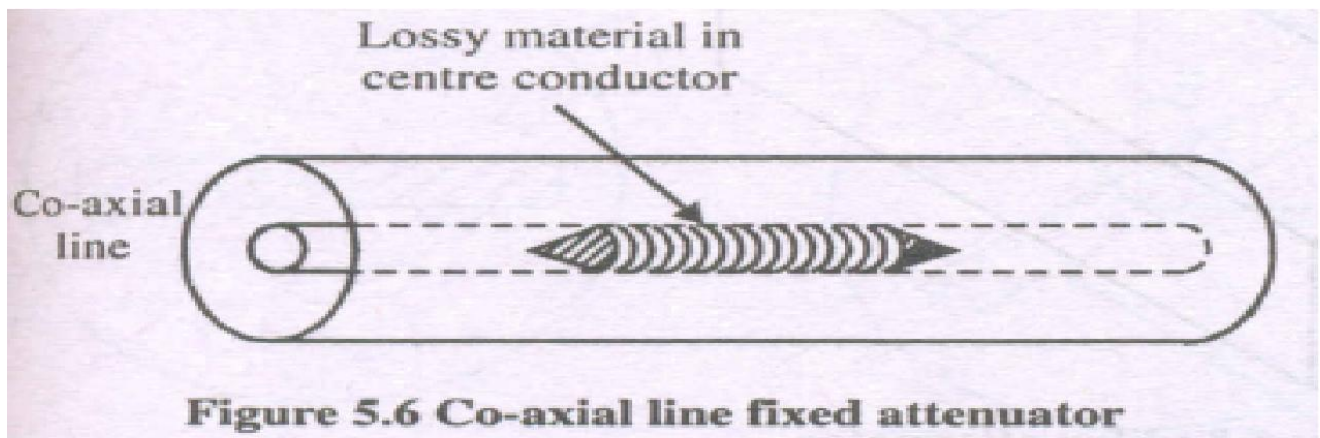

In waveguides, the dielectric slab coated with aduadag is placed at the centre of the waveguide parallel to the maximum E-field for dominant TE₁₀ mode. Induced current on the lossy material due to incoming microwave signal, results in power dissipation, leading to attenuation of the signal. The dielectric slab is tapered at both ends upto a length of more than half wavelength to reduce reflections as shown in figure 5.7. The dielectric slab may be made movable along the breadth of the waveguide by supporting it with two dielectric rods separated by an odd multiple of quarter guide wavelength and perpendicular to electric field. When the slab is at the centre, then the attenuation is maximum (since the electric field is concentrated at the centre for TE₁₀ mode) and when it is moved towards one side-wall, the attenuation goes on decreasing thereby controlling the microwave power coming out of the other port.

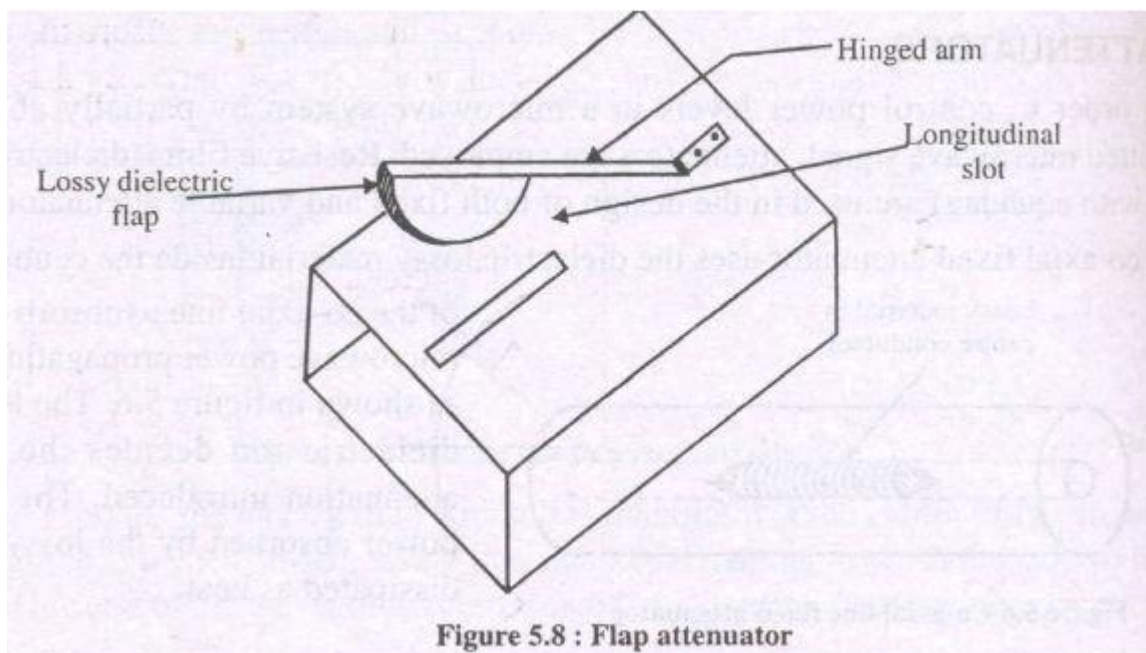

Figure 5.8 shows a flap attenuator which is also a variable attenuator. A semi-circular flap made of lossy dielectric is made to descend into the longitudinal slot cut at the centre of the top wall of rectangular waveguide. When the flap is completely outside the slot, then the attenuation is zero and when it is completely inside, the attenuation is maximum. A maximum direction of 90 dB attenuation is possible with this attenuator with a VSWR of 1.05. The dielectric slab can be properly shaped according to convenience to get a linear variation of attenuation within the depth of insertion. A precision type variable attenuator consists of a rectangular to circular transition (ReT), a piece of circular waveguide (CW) and a circular-to-rectangular transition (CRT) as shown in figure 5.9. Resistive cards R_a , R_b and R_c are placed inside these sections as shown. The centre circular section containing the resistive card R_b

can be precisely rotated by 360° with respect to the two fixed resistive cards. The induced current on the resistive card R due to the incident signal is dissipated as heat producing attenuation of the transmitted signal. TE mode in RCT is converted into TE in circular waveguide. The resistive cards R and R are kept perpendicular to the electric field of TE₁₀ mode so that it does not absorb the energy. But any component parallel to its plane will be readily absorbed. Hence, pure TE mode is excited in circular waveguide section. If the resistive card in the center section is kept at an angle θ relative to the E-field direction of the TE₁₀ mode, the component $E \cos\theta$ parallel to the card gets absorbed while the component $E \sin\theta$ is transmitted without attenuation. This component finally comes out as $E \sin 2\theta$ as shown in figure 5.10.

2.6 PHASE SHIFTERS:

A microwave phase shifter is a two port device which produces a variable shift in phase of the incoming microwave signal. A lossless dielectric slab when placed inside the rectangular waveguide produces a phase shift. The rotary type of precision phase shifter is shown in figure 5.12 which consists of a circular waveguide containing a lossless dielectric plate of length $2l$ called "half-wave section", a section of rectangular-to-circular transition containing a lossless dielectric plate of length l , called "quarter-wave section", oriented at an angle of 45° to the broader wall of the rectangular waveguide and a circular-to-rectangular transition again containing a lossless dielectric plate of same length l (quarter wave section) oriented at an angle 45° . The incident TE₁₀ mode becomes TE₁₁ mode in circular waveguide section. The half-wave section produces a phase shift equal to twice that produced by the quarter wave section. The dielectric plates are tapered at both ends to reduce reflections due to discontinuity.

2.7 WAVE GUIDE TEE JUNCTIONS:

A waveguide Tee is formed when three waveguides are interconnected in the form of English alphabet T and thus waveguide tee is 3-port junction. The waveguide tees are used to connect a branch or section of waveguide in series or parallel with the main waveguide transmission line either for splitting or combining power in a waveguide system. There are basically 2 types of tees namely 1.H- plane Tee junction 2.E-plane Tee junction A combination of these two tee junctions is called a hybrid tee or "Magic Tee". E-plane Tee(series tee): An E-plane tee is a waveguide tee in which the axis of its side arm is parallel to the E field of the main guide. If the collinear arms are symmetric about the side arm.

If the E-plane tee is perfectly matched with the aid of screw tuners at the junction, the diagonal components of the scattering matrix are zero because there will be no reflection.

When the waves are fed into side arm, the waves appearing at port 1 and port 2 of the collinear arm will be in opposite phase and in same magnitude.

2.8 Magic Tee (Hybrid Tees)

A magic tee is a combination of E-plane and H-plane tee. The characteristics of magic tee are:

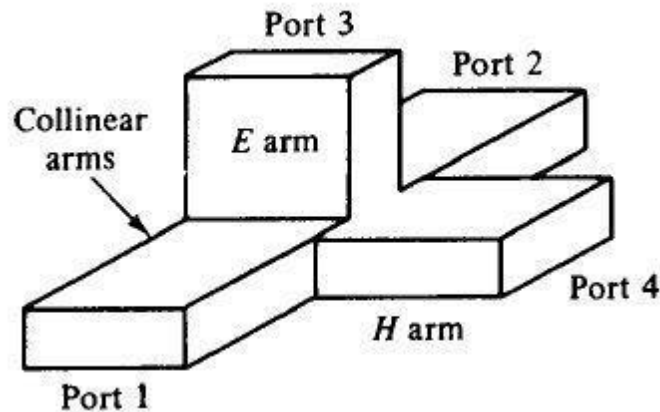

1. If two waves of equal magnitude and same phase are fed into port 1 and port 2 the output will be zero at port 3 and additive at port 4.
3. If a wave is fed into port 4 it will be divided equally between port 1 and port 2 of the collinear arms and will not appear at port 3.
4. If a wave is fed into port 3, it will produce an output of equal magnitude and opposite phase at port 1 and port 2. the output at port 4 is zero.
5. If a wave is fed into one of the collinear arms at port 1 and port 2, it will not appear in the other collinear arm at port 2

OUTCOME:

At the end of the course student will be able to understand and explain the different microwave passive devices and S-parameters.

Recommended Questions

1. What is S-parameter?
2. What is the need for S-parameter
3. Explain Magic-Tee
4. Explain Phase shifter
5. Explain Attenuators.
6. Explain Microwave Passive devices