

MODULE 3

GYROSCOPE

CONTENTS

3.1 INTRODUCTION

3.2 GYROSCOPIC COUPLE

3.3 GYROSCOPIC EFFECT ON SHIP

3.4 GYROSCOPIC EFFECT ON AEROPLANE

3.5 STABILITY OF AUTOMOTIVE VEHICLE

3.1 INTRODUCTION

'Gyre' is a Greek word, meaning 'circular motion' and Gyration means the whirling motion. A gyroscope is a spatial mechanism which is generally employed for the study of precessional motion of a rotary body. Gyroscope finds applications in gyrocompass, used in aircraft, naval ship, control system of missiles and space shuttle. The gyroscopic effect is also felt on the automotive vehicles while negotiating a turn.

A gyroscope consists of a rotor mounted in the inner gimbal. The inner gimbal is mounted in the outer gimbal which itself is mounted on a fixed frame as shown in Fig.1. When the rotor spins about X-axis with angular velocity ω rad/s and the inner gimbal precesses (rotates) about Y-axis, the spatial mechanism is forced to turn about Z-axis other than its own axis of rotation, and the gyroscopic effect is thus setup. The resistance to this motion is called gyroscopic effect.

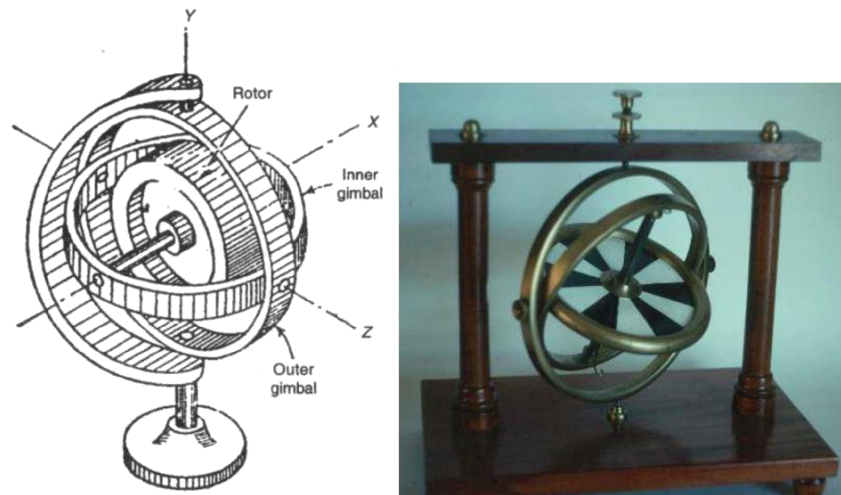

Fig. 1 Gyroscope mechanism

ANGULAR MOTION

A rigid body, (Fig.2) spinning at a constant angular velocity ω rad/s about a spin axis through the mass centre. The angular momentum 'H' of the spinning body is represented by a **vector** whose magnitude is ' $I\omega$ '. I represents the mass amount of inertia of the rotor about the axis of spin.

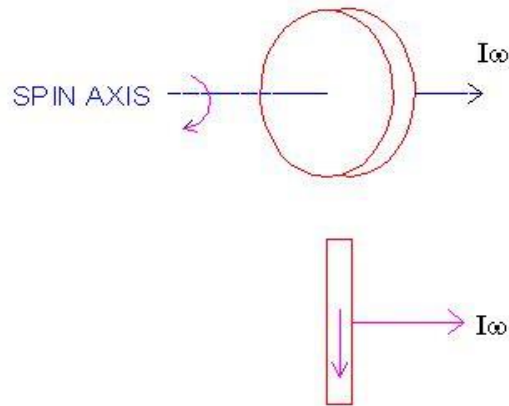

Fig.2 Spinning body

∴ $H = I\omega$

The direction of the angular momentum can be found from the right hand screw rule or the right hand thumb rule. Accordingly, if the fingers of the right hand are bent in the direction of rotation of rotor, then the thumb indicates the direction of momentum.

3.2 GYROSCOPIC COUPLE

Consider a rotary body of mass m having radius of gyration k mounted on the shaft supported at two bearings. Let the rotor spins (rotates) about X-axis with constant angular velocity ω rad/s. The X-axis is, therefore, called spin axis, Y-axis, precession axis and Z-axis, the couple or torque axis (Fig.3).

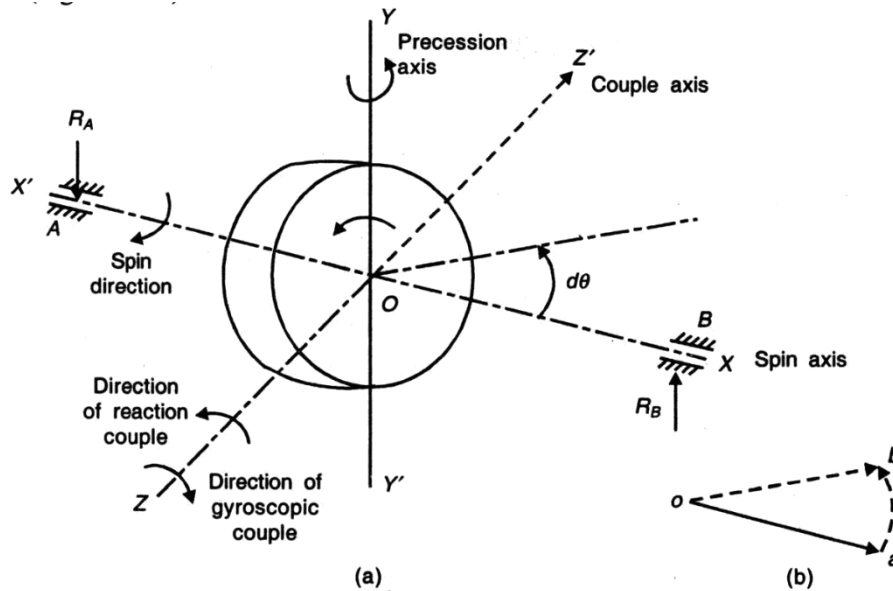

Fig. 3

Now, suppose the shaft axis (X-axis) precesses through a small angle $\delta\theta$ about Y-axis in the plane XOZ, then the angular momentum varies from H to $H + \delta H$, where δH is the change in the angular momentum, represented by vector ab [Figure 15.2(b)]. For the small value of angle of rotation $\delta\theta$, we can write

$$ab = oa \times \delta\theta$$

$$\delta H = H \times \delta\theta$$

$$= I\omega\delta\theta$$

However, the rate of change of angular momentum is:

$$C = \frac{dH}{dt} = \lim_{\delta t \rightarrow 0} \left(\frac{I\omega\delta\theta}{\delta t} \right)$$

$$= I\omega \frac{d\theta}{dt}$$

or

$$C = I\omega W_p$$

where C = gyroscopic couple (N-m)
 ω = angular velocity of rotary body (rad/s)
 W_p = angular velocity of precession (rad/s)

Direction of Spin vector, Precession vector and Couple/Torque vector with forced precession

To determine the direction of spin, precession and torque/couple vector, right hand screw rule or right hand rule is used. The fingers represent the rotation of the disc and the thumb shows the direction of the spin, precession and torque vector (Fig.4).

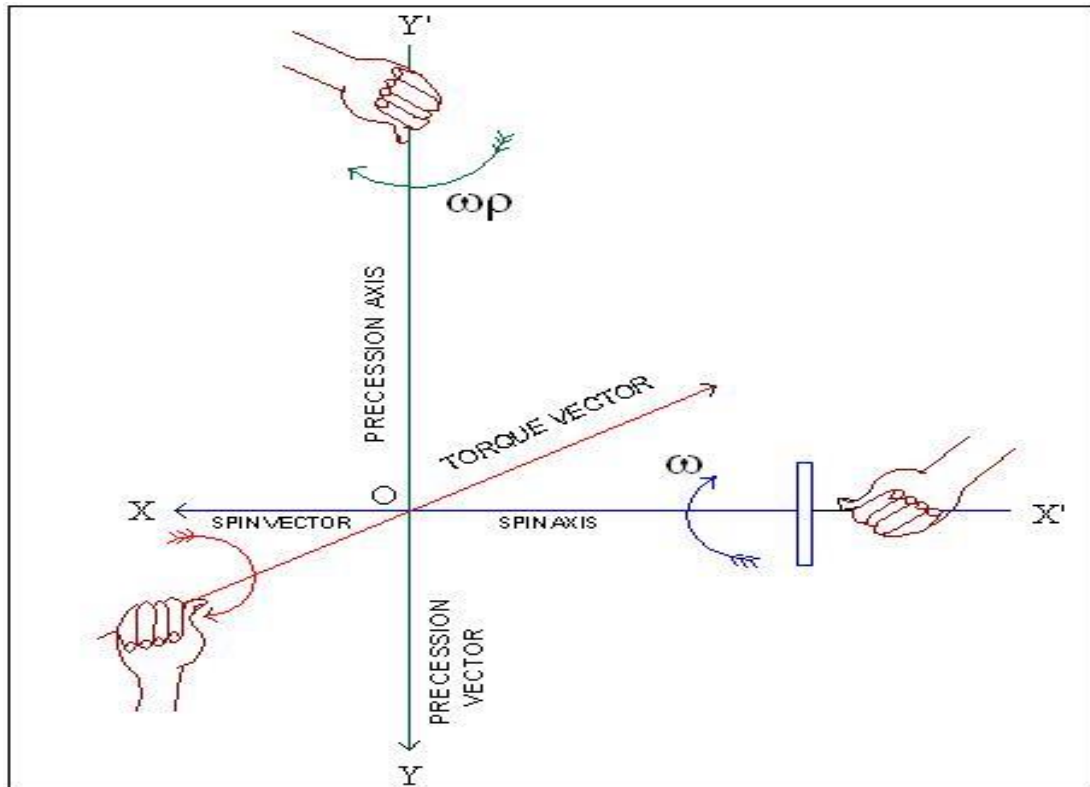

Fig.4. Direction of Spin vector, Precession vector and Couple/Torque vector

The method of determining the direction of couple/torque vector is as follows.

Case (i):

Consider a rotor rotating in anticlockwise direction when seen from the right (Fig.5 and Fig. 6), and to precess the spin axis about precession axis in clockwise and anticlockwise direction when seen from top. Then, to determine the active/reactive gyroscopic couple vector, the following procedure is used.

1. Turn the spin vector through 90° in the direction of precession on the XOZ plane
2. The turned spin vector will then correspond to the direction of active gyroscopic couple/torque vector
3. The reactive gyroscopic couple/torque vector is taken opposite to active gyro vector direction

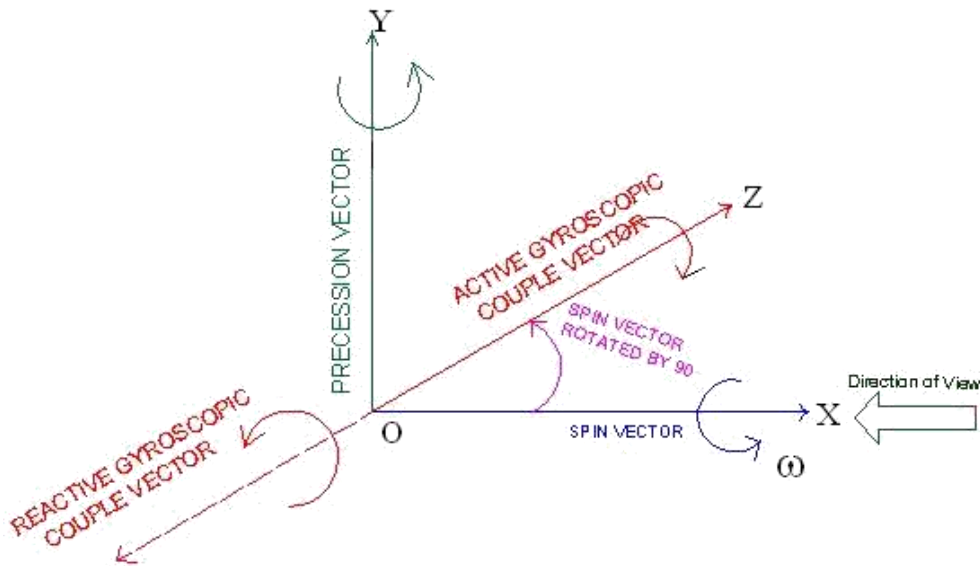

Fig. 5 Direction of active and reactive gyroscopic couple/torque vector

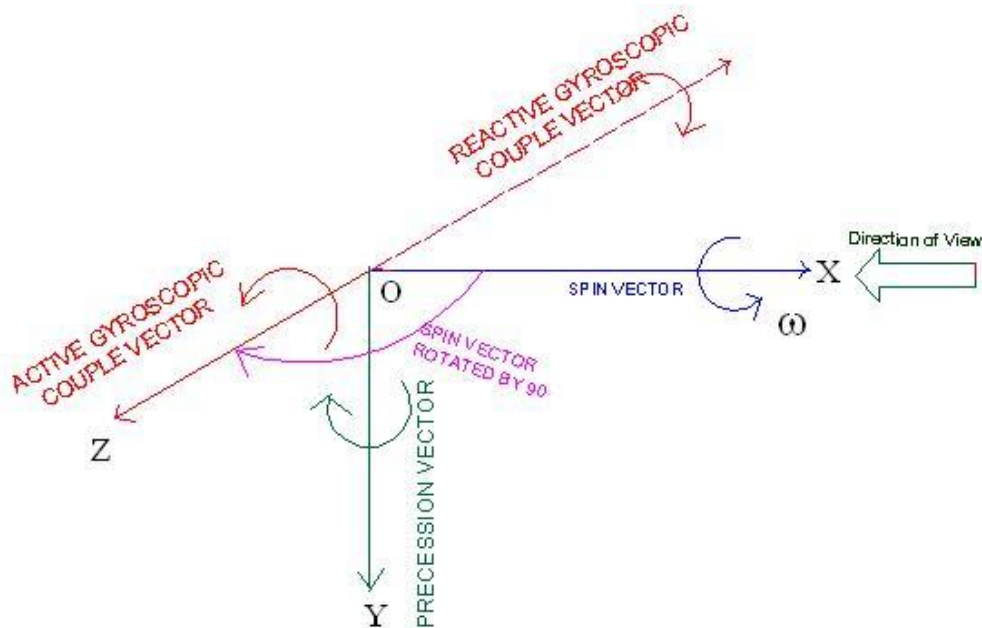

Fig. 6 Direction of active and reactive gyroscopic couple/torque vector

Case (ii):

Consider a rotor rotating in clockwise direction when seen from the right (Fig.7 and Fig. 8), and to precess the spin axis about precession axis in clockwise and anticlockwise direction when seen from top. Then, to determine the active/reactive gyroscopic couple vector,

1. Turn the spin vector through 90^0 in the direction of precession on the XOZ plane
2. The turned spin vector will then correspond to the direction of active gyroscopic couple/torque vector
 The reactive gyroscopic couple/torque vector is taken opposite to active gyro vector direction

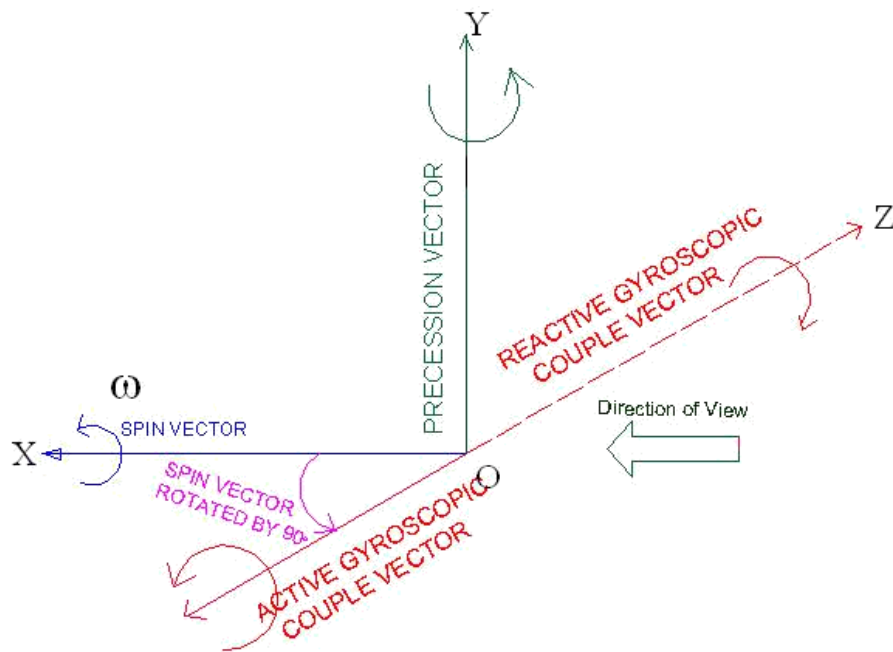

Fig. 7 Direction of active and reactive gyroscopic couple/torque vector

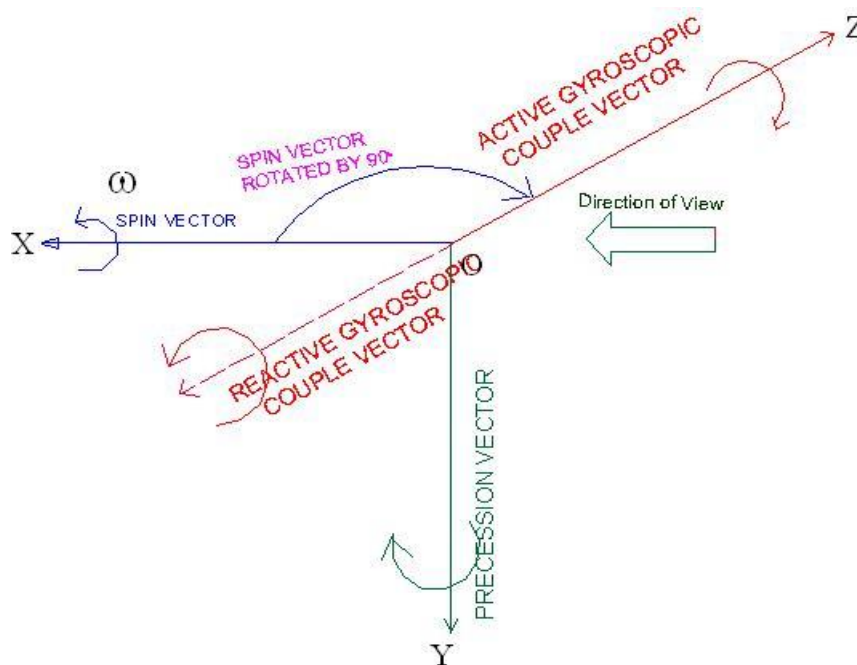

Fig. 8 Direction of active and reactive gyroscopic couple/torque vector

The resisting couple/ reactive couple will act in the direction opposite to that of the gyroscopic couple. This means that, whenever the axis of spin changes its direction, a **gyroscopic couple** is applied to it through the bearing which supports the spinning axis.

Please note that, for analyzing the gyroscopic effect of the body, always reactive gyroscopic couple is considered.

Problem 1

A disc of 5 kg mass with radius of gyration 70 mm is mounted at span on a horizontal shaft spins at 720 rpm in clockwise direction when viewed from the right hand bearing. If the shaft precesses about the vertical axis at 30 rpm in clockwise direction when viewed from the top, determine the reactions at each bearing due to mass of the disc and gyroscopic effect.

Solution Angular velocity:

$$\begin{aligned}\omega &= \frac{2\pi N}{60} = \frac{2\pi \times 720}{60} \\ &= 75.4 \text{ rad/s}\end{aligned}$$

$$\begin{aligned}\text{Angular velocity of precession: } \omega_p &= \frac{2\pi N_p}{60} \\ &= \frac{2\pi \times 30}{60} = 3.14 \text{ rad/s}\end{aligned}$$

$$\begin{aligned}\text{Moment of inertia: } I &= mk^2 \\ &= 5 \times 0.07^2 = 0.0245 \text{ kg m}^2\end{aligned}$$

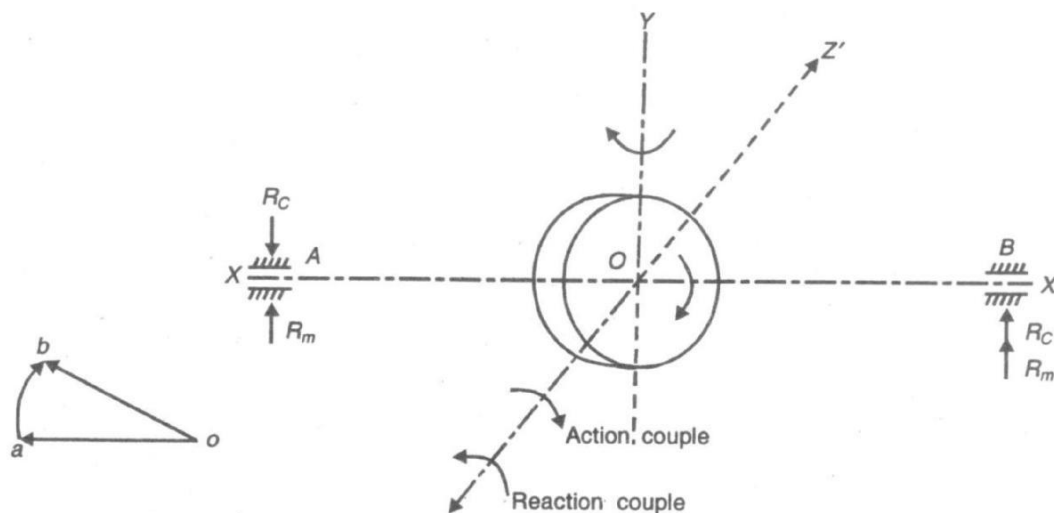

FIG. 9a

Gyroscopic couple:

$$\begin{aligned}C &= I \omega \omega_p \\ &= 0.0245 \times 75.4 \times 3.14 \\ &= 5.8 \text{ Nm}\end{aligned}$$

This couple induces reaction R_c at the bearing support.

$$R_c \times \frac{120}{1000} = 5.8$$

or

$$R_c = 48.3 \text{ N}$$

Reaction on the bearings due to weight of the disc, $R_m = mg/2 = 5 \times 9.81 / 2 = 24.53 \text{ N}$

The angular momentum vector and induced reactive gyroscopic couple acting in anticlockwise direction is shown in Fig.9b.

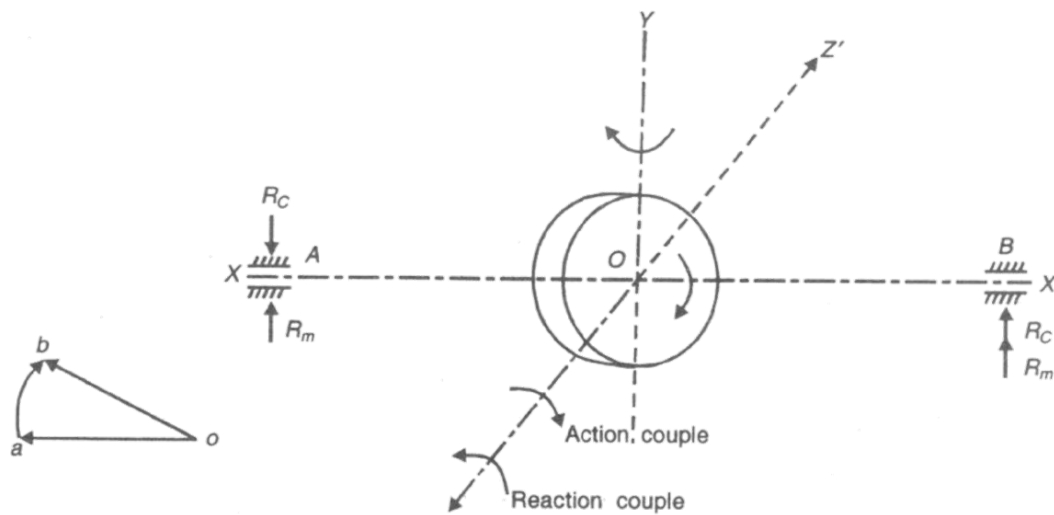

FIG.9b

Gyroscopic couple:

$$C = I \omega \omega_p$$

$$= 0.0245 \times 75.4 \times 3.14$$

$$= 5.8 \text{ Nm}$$

This couple induces reaction R_c at the bearing support.

$$R_c \times \frac{120}{1000} = 5.8$$

or

$$R_c = 48.3 \text{ N}$$

The reaction R_c acts in upward direction at right hand bearing and in downward direction at left hand bearing.

The reaction due to weight of the disc acts in upward direction. Therefore,

Reaction at bearing A:

$$R_A = R_c - R_m$$

$$= 48.43 - 24.53$$

$$= 23.9 \text{ N}(\downarrow)$$

Reaction at bearing B:

$$R_B = R_c + R_m$$

$$= 48.43 + 24.53$$

$$= 72.96 \text{ N}(\uparrow)$$

3.3 GYROSCOPIC EFFECT ON SHIP

Gyroscope is used for stabilization and directional control of a ship sailing in the rough sea. A ship, while navigating in the rough sea, may experience the following three different types of motion:

- r Steering—The turning of ship in a curve while moving forward
- r Pitching—The movement of the ship up and down from horizontal position in a vertical plane about transverse axis
- (iii)Rolling—Sideway motion of the ship about longitudinal axis.

For stabilization of a ship against any of the above motion, the major requirement is that the gyroscope shall be made to precess in such a way that reaction couple exerted by the rotor opposes the disturbing couple which may act on the frame.

r Ship Terminology

Bow – It is the fore end of ship

Stern – It is the rear end of ship

Starboard – It is the right hand side of the ship looking in the direction of motion

Port – It is the left hand side of the ship looking in the direction of motion

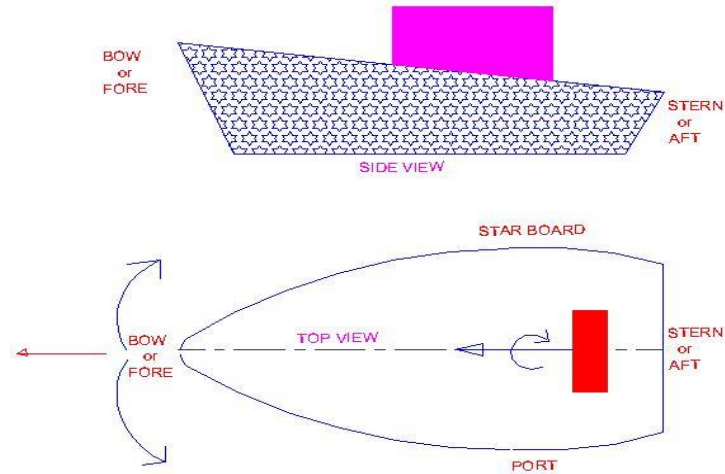

Fig. 10

Consider a gyro-rotor mounted on the ship along longitudinal axis (X-axis) as shown in Fig.10 and rotate in clockwise direction when viewed from rear end of the ship. The angular speed of the rotor is ω rad/s. The direction of angular momentum vector oa , based on direction of rotation of rotor, is decided using right hand thumb rule as discussed earlier. The gyroscopic effect during the three types of motion of ship is discussed.

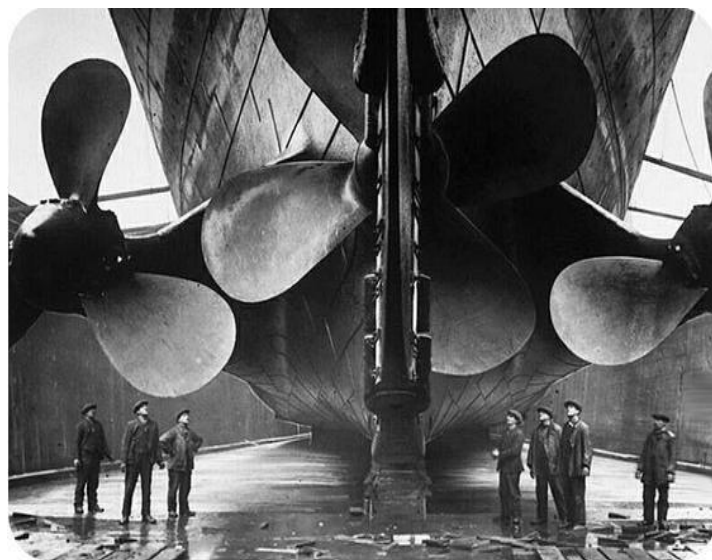

Fig.11

Gyroscopic effect on Steering of ship

+ *Left turn with clockwise rotor*

When ship takes a left turn and the **rotor rotates in clockwise direction** viewed from stern, the gyroscopic couple act on the ship is analyzed in the following way.

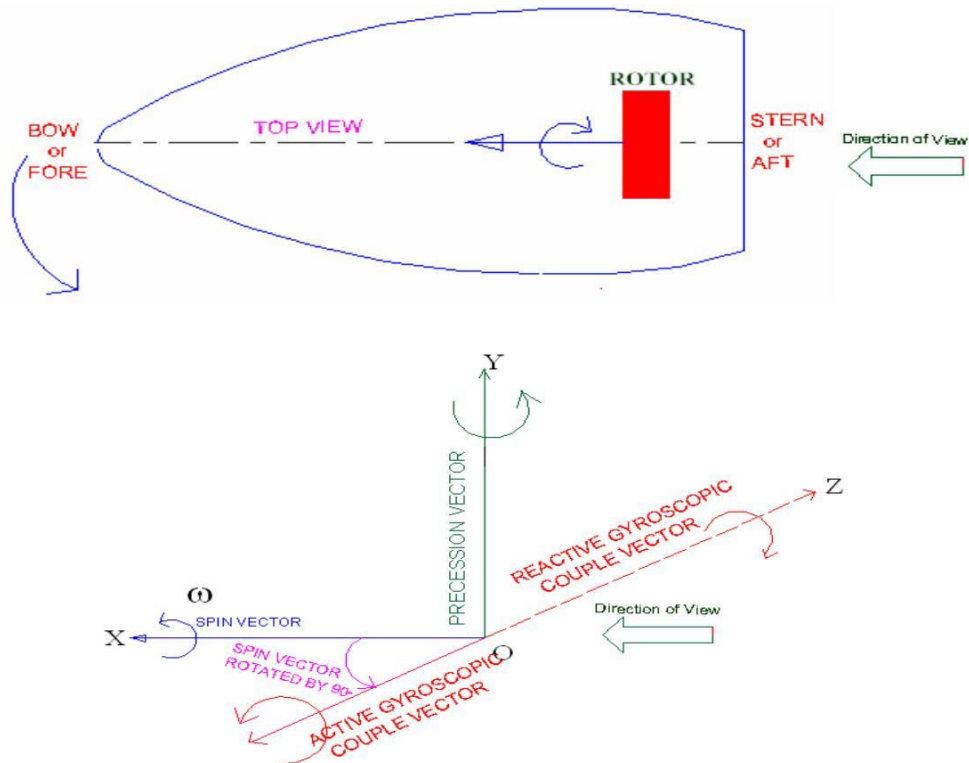

Fig. 12

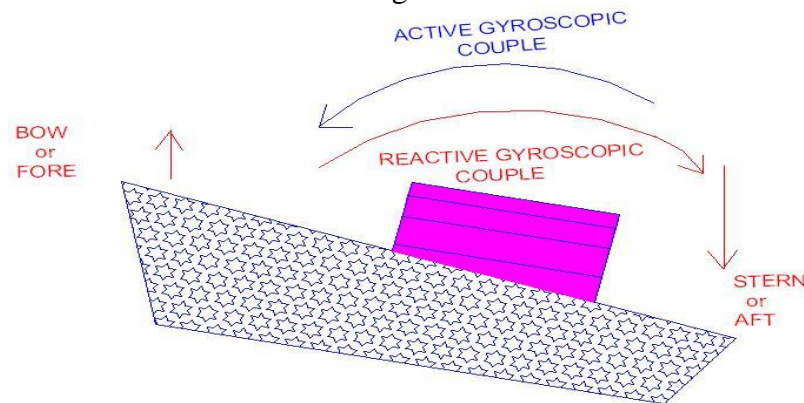

Fig. 13

Note that, always reactive gyroscopic couple is considered for analysis. From the above analysis (Fig.12), the couple acts over the ship between stern and bow. This reaction couple tends to raise the front end (bow) and lower the rear end (stern) of the ship.

(ii) *Right turn with clockwise rotor*

When ship takes a right turn and the **rotor rotates in clockwise direction** viewed from stern, the gyroscopic couple acts on the ship is analyzed (Fig 14). Again, the couple acts in vertical plane, means between stern and bow. Now the reaction couple tends to lower the bow of the ship and raise the stern.

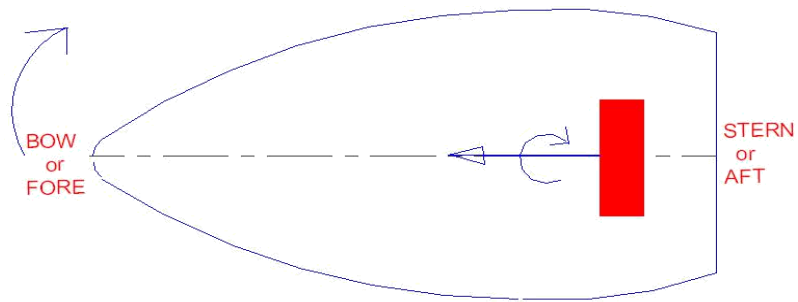

Fig. 14

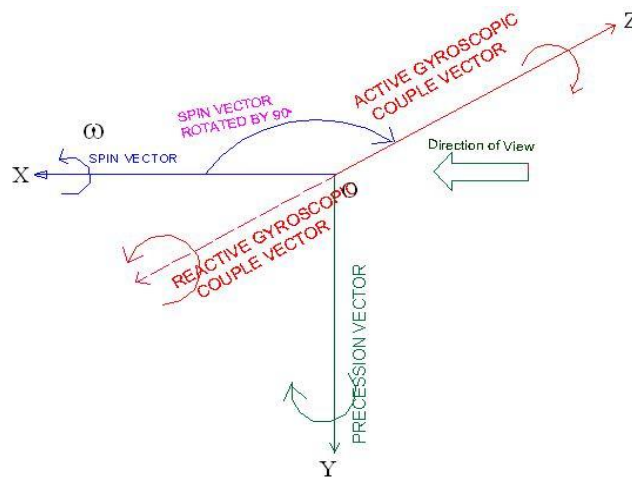

Fig.15

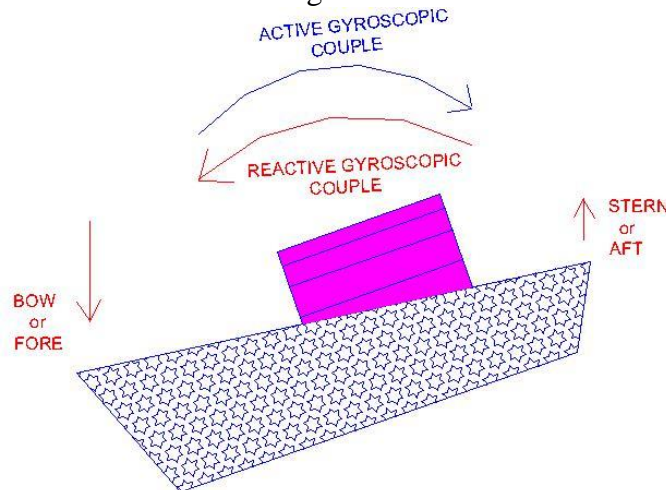

Fig. 16

Left turn with anticlockwise rotor

When ship takes a left turn and the **rotor rotates in anticlockwise direction** viewed from stern, the gyroscopic couple act on the ship is analyzed in the following way (Fig.18).

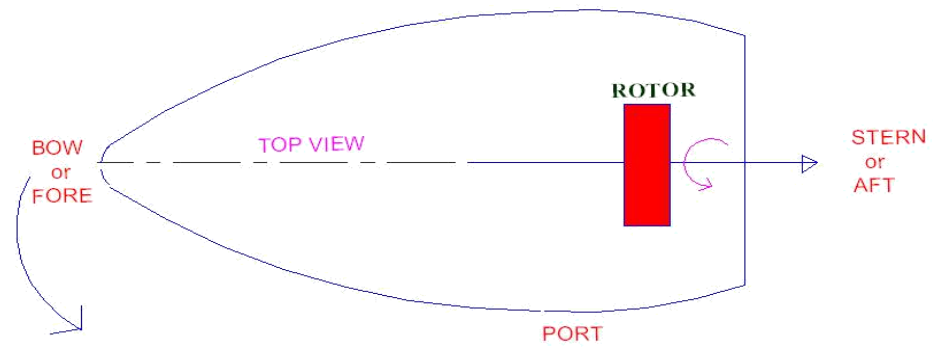

Fig. 17

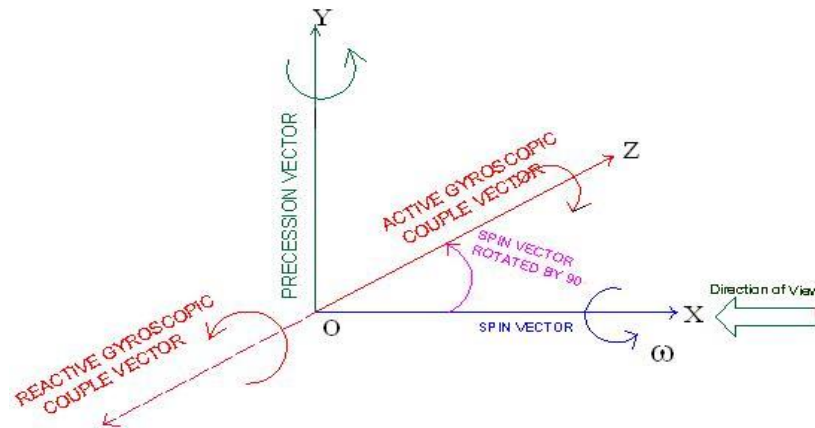

Fig.18

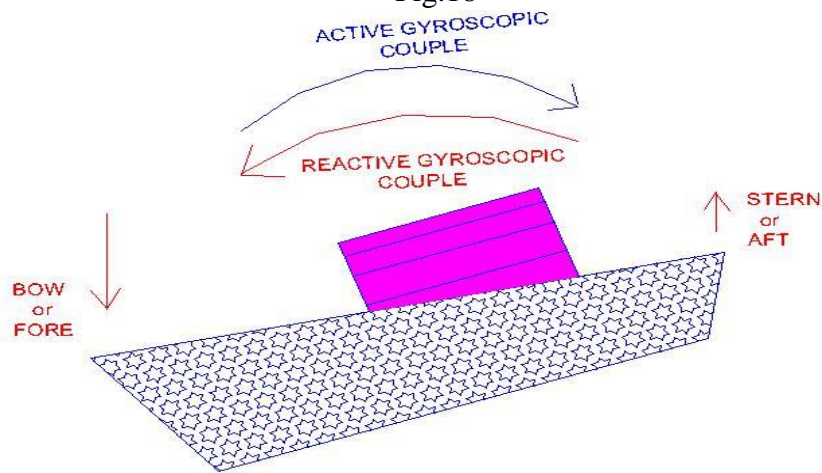

Fig. 19

The couple acts over the ship is between stern and bow. This reaction couple tends to press or dip the front end (bow) and raise the rear end (stern) of the ship.

(iv) Right turn with anticlockwise rotor

When ship takes a right turn and the **rotor rotates in anticlockwise direction** viewed from stern, the gyroscopic couple act on the ship is according to Fig 20. Now, the reaction couple tends to raise the bow of the ship and dip the stern.

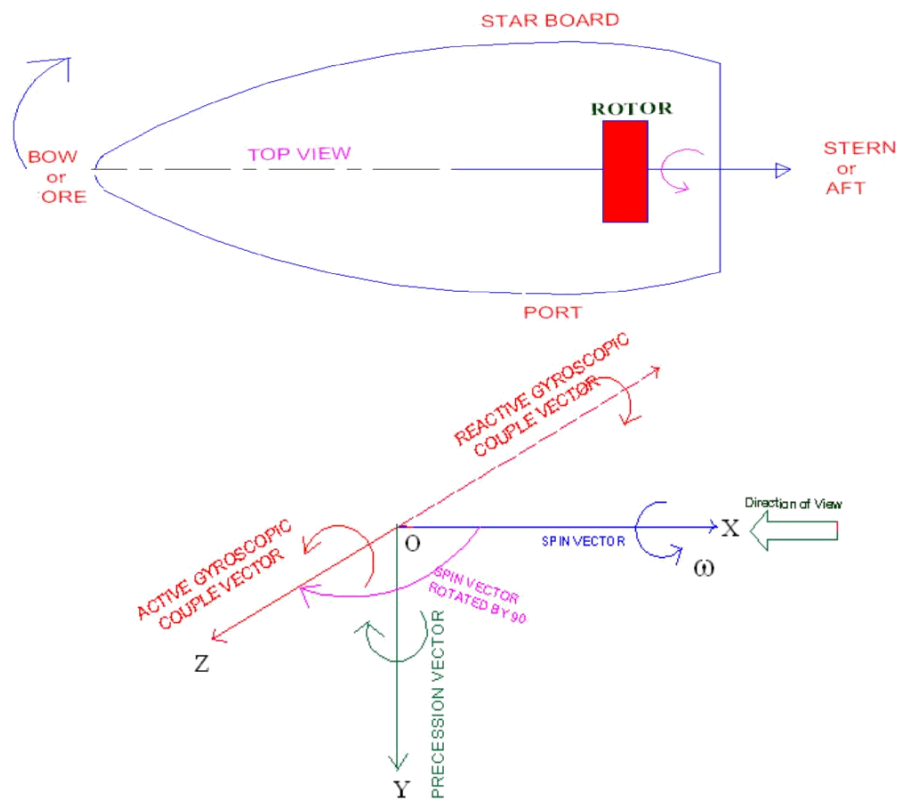

Fig.20

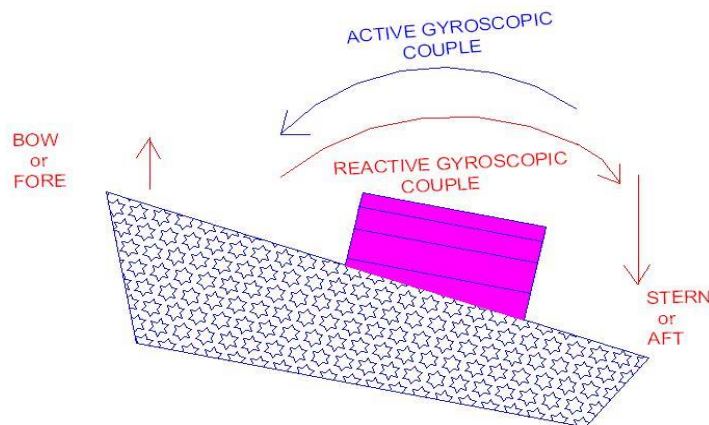

Fig. 21

Gyroscopic effect on Pitching of ship

The pitching motion of a ship generally occurs due to waves which can be approximated as sine wave. During pitching, the ship moves up and down from the horizontal position in vertical plane (Fig.22. & Fig. 23)



Fig.22 Pitching action of ship

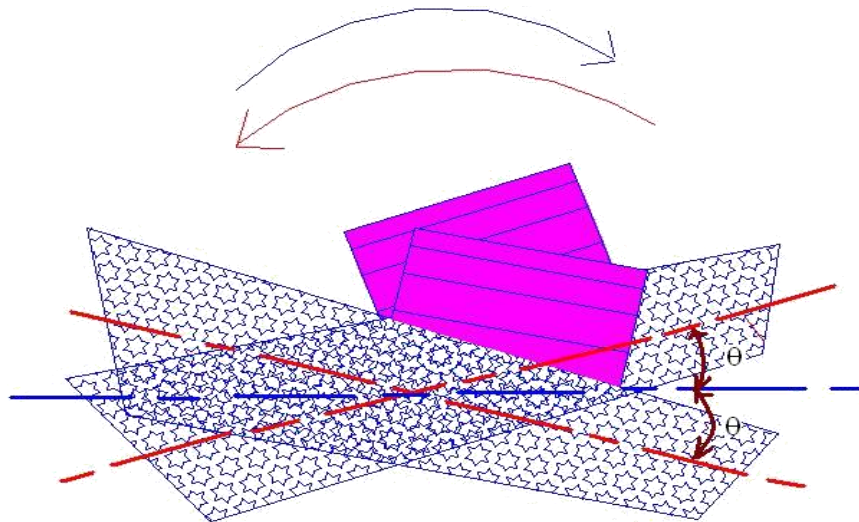

Fig.23 Pitching action of ship

Let θ = angular displacement of spin axis from its mean equilibrium position

A = amplitude of swing

$$\left(= \text{angle in degree} \times \frac{2\pi}{360^\circ} \right)$$

and ω_0 = angular velocity of simple harmonic motion $\left(= \frac{2\pi}{\text{time period}} \right)$

The angular motion of the rotor is given as

$$\theta = A \sin \omega_0 t$$

Angular velocity of precess:

$$\begin{aligned} \omega_p &= \frac{d\theta}{dt} \\ &= \frac{d}{dt} (A \sin \omega_0 t) \end{aligned}$$

or

$$\omega_p = A \omega_0 \cos \omega_0 t$$

The angular velocity of precess will be maximum when $\cos \omega_0 t = 1$

or

$$\begin{aligned} \omega_{p \max} &= A \omega_0 \\ &= A \times \frac{2\pi}{t} \end{aligned}$$

Thus the gyroscopic couple:

$$C = I \omega \omega_p$$

Consider a rotor mounted along the longitudinal axis and rotates in clockwise direction when seen from the rear end of the ship. The direction of momentum for this condition is shown by vector ox (Fig.24). When the ship moves up the horizontal position in vertical plane by an angle θ from the axis of spin, the rotor axis (X-axis) precesses about Z-axis in XY-plane and for this case Z-axis becomes precession axis. The gyroscopic couple acts in anticlockwise direction about Y-axis and the reaction couple acts in opposite direction, i.e. in clockwise direction, which tends to move towards right side (Fig.25). However, when the ship pitches down the axis of spin, the direction of reaction couple is reversed and the ship turns towards left side (Fig. 26).

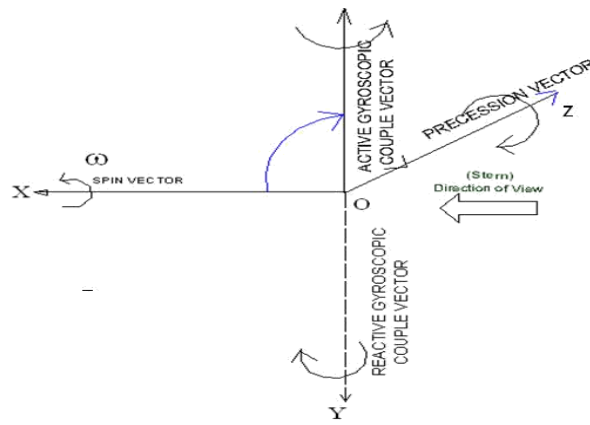

Fig. 24

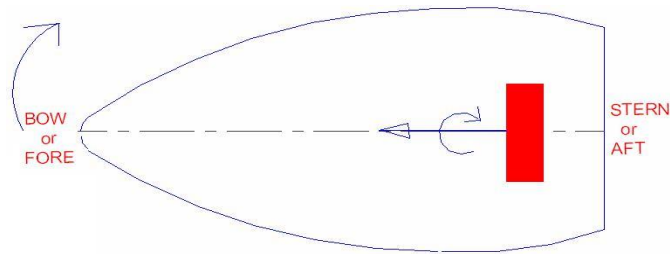

Fig. 25

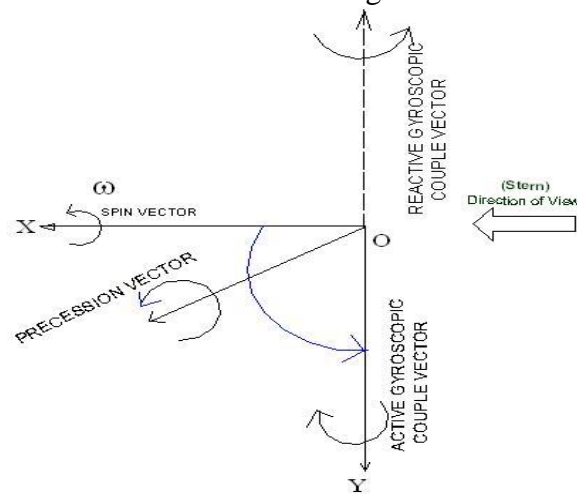

Fig.18

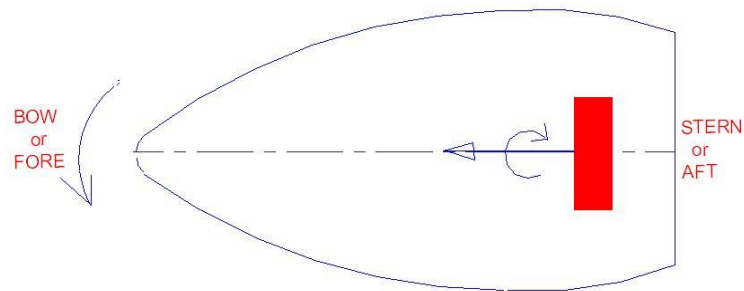

Fig.26

Similarly, for the anticlockwise direction of the rotor viewed from the rear end (Stern) of the ship, the analysis may be done.

Gyroscopic effect on Rolling of ship.

The axis of the rotor of a ship is mounted along the longitudinal axis of ship and therefore, there is **no** precession of this axis. Thus, **no effect of gyroscopic couple** on the ship frame is formed when the ship rolls.



Fig.27

Problem 2

A turbine rotor of a ship has a mass of 3500 kg and rotates at a speed of 2000 rpm. The rotor has a radius of gyration of 0.5 m and rotates in clockwise direction when viewed from the stern (rear) end. Determine the magnitude of gyroscopic couple and its direction for the following conditions

- A When the ship runs at a speed of 12 knots and steers to the left in a curve of 70 m radius
- A When the ship pitches 6° above and 6° below the horizontal position and the bow (Front) end is lowered. The pitching motion is simple harmonic with periodic time 30 sec.
- (iii) When the ship rolls and at a certain instant, it has an angular velocity of 0.05 rad/s clockwise when viewed from the stern

Also find the maximum angular acceleration during pitching.

Solution Given, 1 knot = 1.86 kmph, the linear velocity of the ship:

$$\begin{aligned} V &= 1.86 \times 12 = 22.32 \text{ kmph} \\ &= \frac{22.32 \times 1000}{3600} = 6.2 \text{ m/s} \end{aligned}$$

$$\begin{aligned} \text{Angular velocity of the rotor: } \omega &= \frac{2\pi N}{60} = \frac{2\pi \times 2000}{60} \\ &= 209.44 \text{ rad/s} \end{aligned}$$

Precession velocity: $\omega_p = \frac{V}{R} = \frac{6.2}{70} = 0.08857 \text{ rad/s}$

Moment of inertia: $I = mk^2 = 3500 \times 0.5^2 = 875 \text{ kg m}^2$

Gyroscopic couple: $C = I\omega\omega_p$
 $= 875 \times 209.44 \times 0.08857$
 $= 16231.34 \text{ Nm}$

When ship steers to the left, the reaction gyroscopic couple action is in anticlockwise direction and the bow of the ship is raised and stern is lowered, as shown in Fig.28.

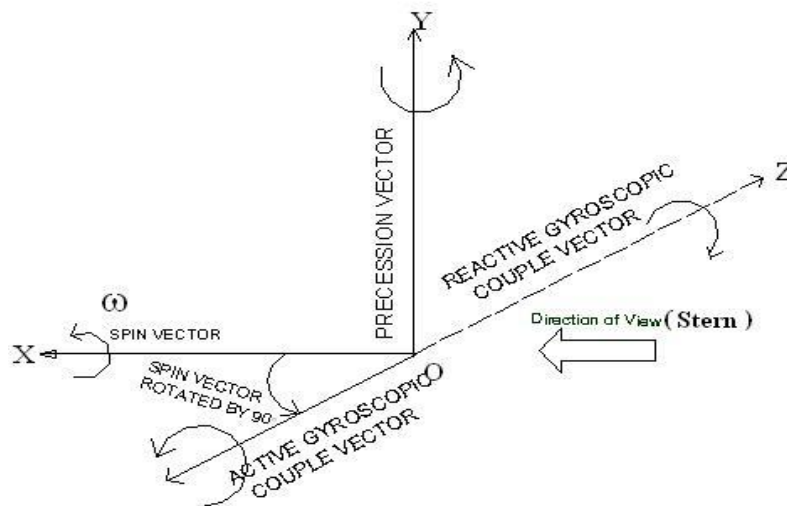

Fig.28

(ii) Amplitude of swing: $A = \frac{6^\circ \times 2\pi}{360^\circ} = 0.1047 \text{ rad}$

Angular displacement: $\theta = A \sin \omega_0 t$

Angular velocity of precession: $\omega_p = \frac{d\theta}{dt} = A\omega_0 \cos \omega_0 t$

Maximum angular velocity of precession:

$$\omega_{p\max} = \omega_0 A$$

where $\omega_0 = \frac{2\pi}{\text{time period of oscillation}} = \frac{2\pi}{30}$
 $= 0.2094 \text{ rad/s}$

$$W_{p\max} = 0.2094 \times 0.1047 = 0.022 \text{ rad/s}$$

Maximum couple for pitching:

$$C_{\max} = I W W_{p\max}$$

$$= 4.875 \times 209.44 \times 0.022$$

$$= 5.4031.72 \text{ Nm}$$

The effect of gyroscopic couple due to pitching is shown in Fig.29. The reactive gyroscopic couple will act in anticlockwise direction seen from top and it will turn ship **towards the left side**.

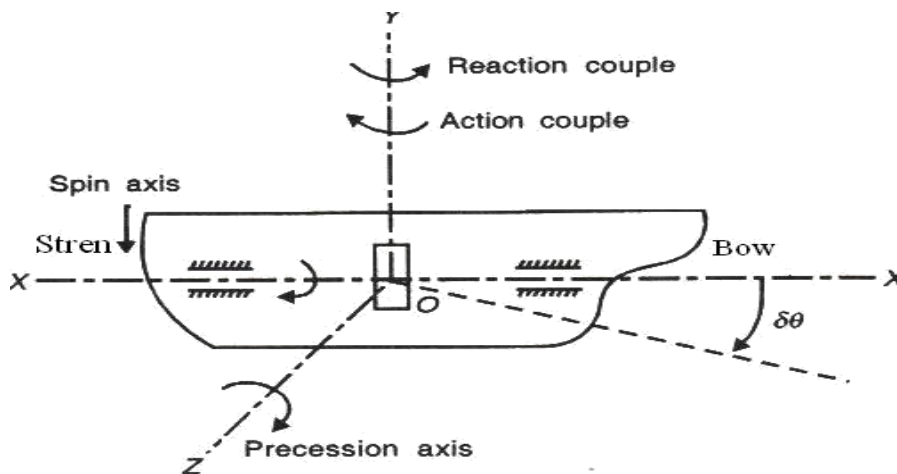

Fig.29

iii) Angular velocity of precession while the ship rolls is:

$$W_p = 0.05 \text{ rad/s}$$

$$\begin{aligned} \text{and gyroscopic couple : } C &= I W W_p \\ &= 875 \times 209.44 \times 0.05 \\ &= 9163 \text{ Nm} \end{aligned}$$

Since the ship rolls in the same plane as the plane of spin, there **is no gyroscopic effect**.

Angular velocity of precession during pitching is:

$$\omega_p = \frac{d\theta}{dt} = A \omega_0 \cos \omega_0 t$$

Therefore, angular acceleration:

$$\alpha = \frac{d^2\theta}{dt^2} = -A \omega_0^2 \sin \omega_0 t$$

Maximum angular acceleration:

$$\begin{aligned} W_{\max} &= -A W_0^2 \\ &= 0.1047 \times 0.2094^2 \\ &= 0.00459 \text{ rad/s}^2 \end{aligned}$$

Problem 3

A ship is propelled by a rotor of mass of 2000 kg rotates at a speed of 2400 rpm. The radius of gyration of rotor is 0.4 m and spins clockwise direction when viewed from bow (front) end. Find the gyroscopic couple and its effect when;

- = the ship takes left turn at a radius of 350 m with a speed of 35 kmph
- = the ship pitches with the bow rising at an angular velocity of 1 rad/s (ii) the ship rolls at an angular velocity of 0.15 rad/s

Solution

Angular velocity:

$$\omega = \frac{2\pi N}{60} = \frac{2\pi \times 2400}{60} = 251.33 \text{ rad/s}$$

Linear velocity: $V = 35 \text{ kmph} = \frac{35 \times 1000}{3600} = 9.72 \text{ m/s}$

Moment of inertia: $I = mk^2 = 2000 \times 0.4^2 = 320 \text{ kg m}^2$

Steering towards left

Angular velocity of precession: $\omega_p = \frac{V}{R} = \frac{9.72}{350} = 0.0278 \text{ rad/s}$

Gyroscopic couple: $C = I\omega\omega_p$
 $= 320 \times 251.33 \times 0.0278$
 $= 2235.8 \text{ Nm}$

The reaction gyroscopic couple will act in anticlockwise and will tend to **lower the bow** as shown in Figure 30.

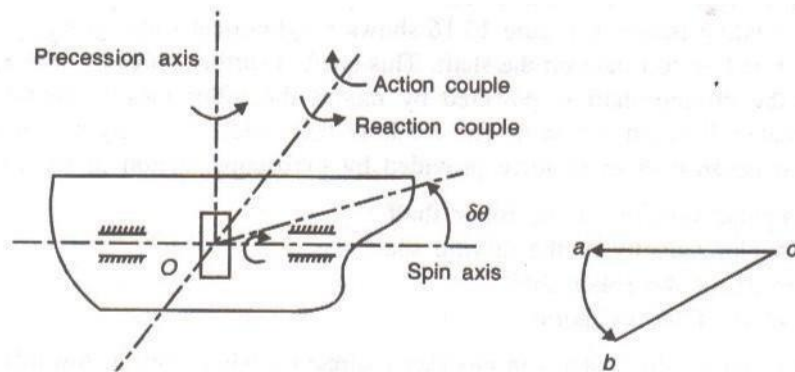

Fig.30

Pitching. Angular velocity of precession during pitching $\omega_p = 1.0 \text{ rad/s}$

Gyroscopic couple: $C = 320 \times 251.33 \times 1.0$
 $= 80425.6 \text{ Nm Ans.}$

The reaction gyroscopic couple acting in anticlockwise direction will tend to turn the **bow towards the Right side** as shown in Figure 31.

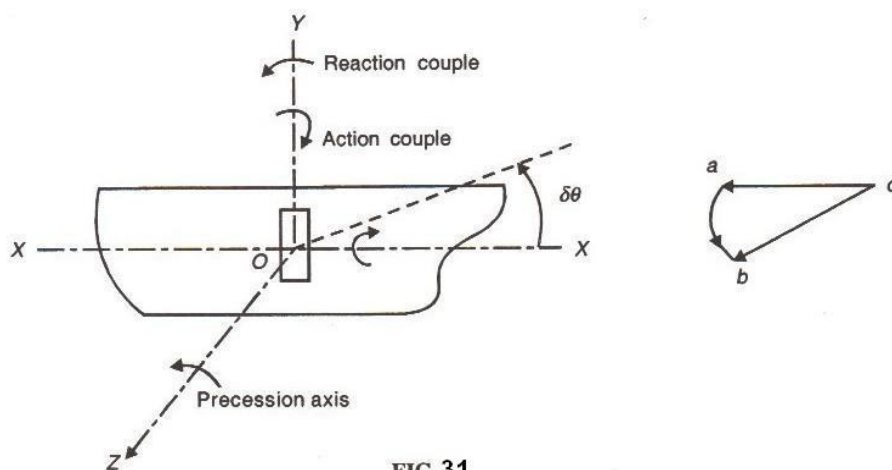

FIG.31

Rolling, Gyroscopic couple: $C = 16XQ_p$
 $= 320 \times 251.33 \times 0.15 = 12063.84 \text{ Nm}$

During rolling, the ship rolls in the same plane as the plane of spin and there will be no gyroscopic effect.

3.4 Gyroscopic Effect on Aeroplane

Aeroplanes are subjected to gyroscopic effect when it taking off, landing and negotiating left or right turn in the air.

Let

ω = Angular velocity of the engine rotating parts in rad/s,

m = Mass of the engine and propeller in kg,

r_w = Radius of gyration in m,

I = Mass moment of inertia of engine and propeller in kg m^2 ,

V = Linear velocity of the aeroplane in m/s,

R = Radius of curvature in m,

ω_p = Angular velocity of precession = $\frac{V}{R}$ rad/s

∴ Gyroscopic couple acting on the aero plane = $C = I \omega \omega_p$

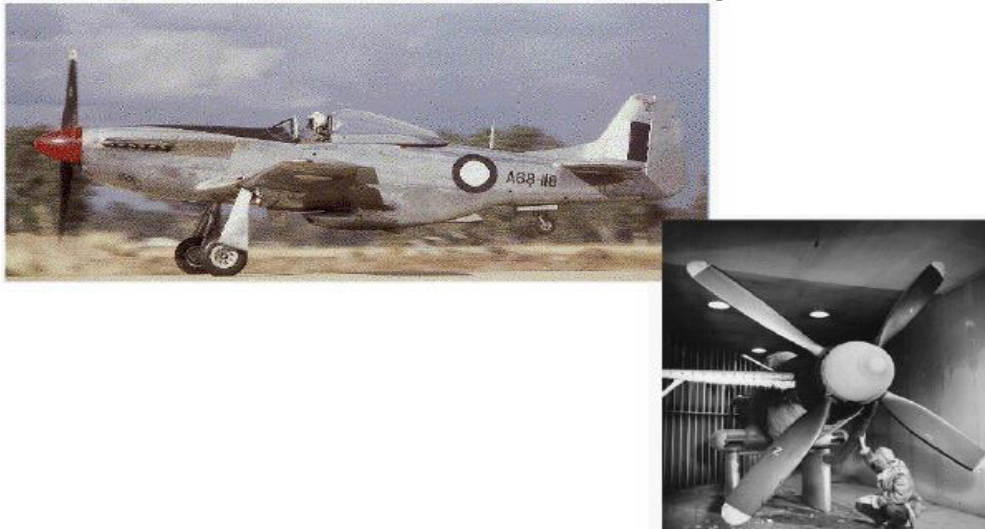
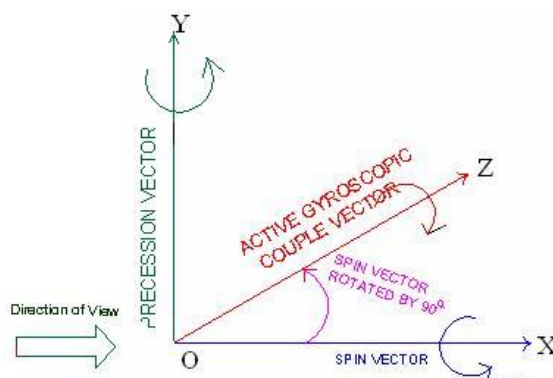
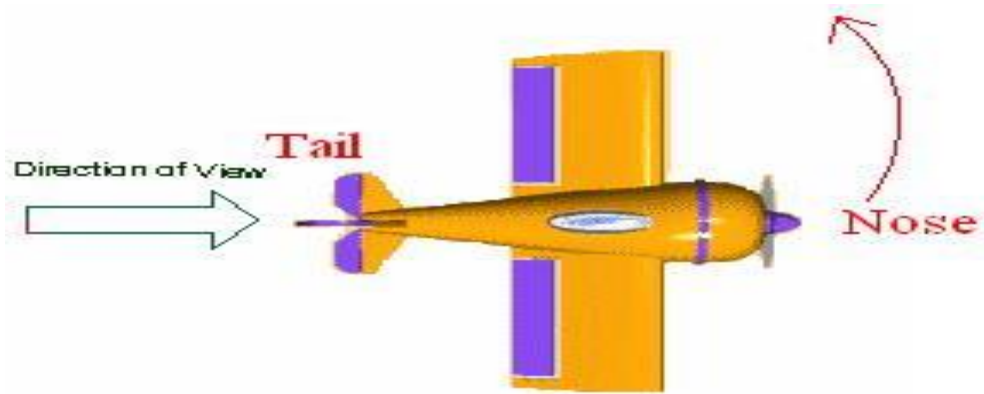
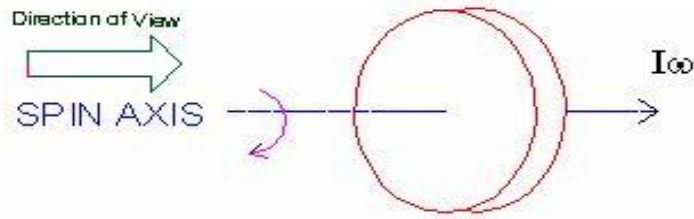

Fig.32

Let us analyze the effect of gyroscopic couple acting on the body of the aero plane for various conditions.

Case (i): PROPELLER rotates in **CLOCKWISE** direction when seen from rear end and Aeroplane turns towards **LEFT**





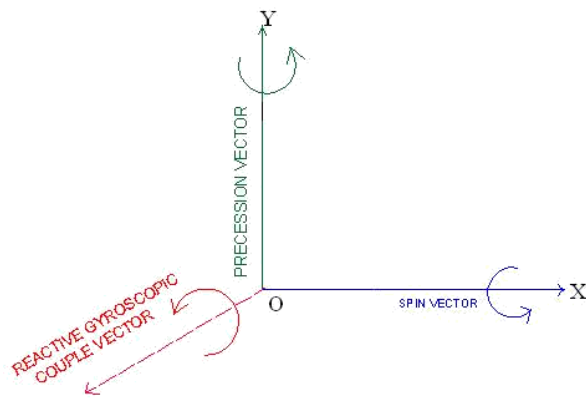

Fig.38

According to the analysis, the reactive gyroscopic couple tends to **dip the tail** and **raise the nose** of aeroplane.

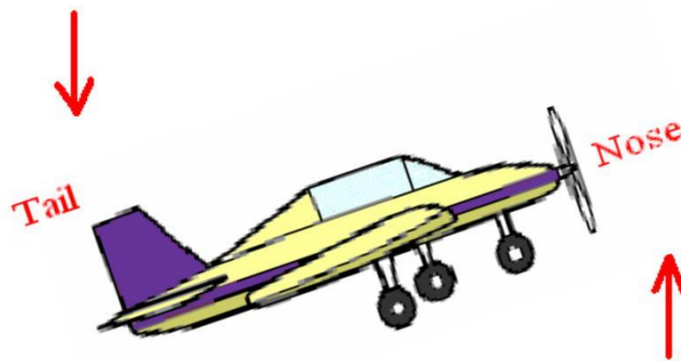

Fig.39

Case (ii): **PROPELLER** rotates in **CLOCKWISE** direction when seen from rear end and Aeroplane turns towards **RIGHT**

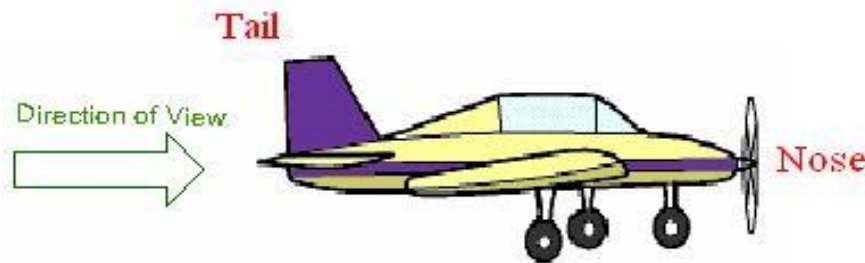

Fig.40

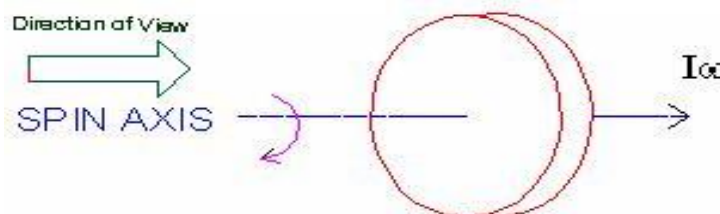

Fig.41

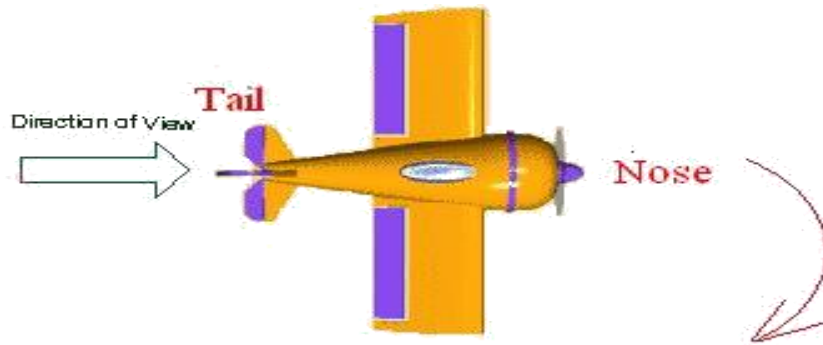

Fig.42

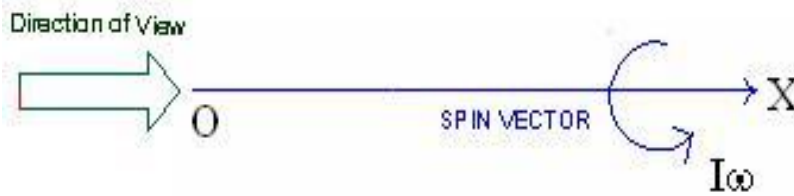

Fig.43

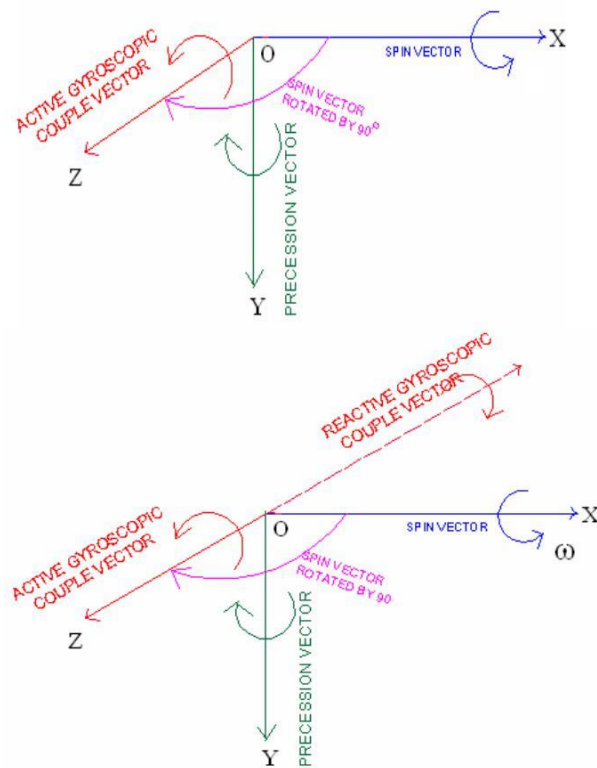

Fig. 44

According to the analysis, the reactive gyroscopic couple tends to **raise the tail** and **dip the nose** of aeroplane.

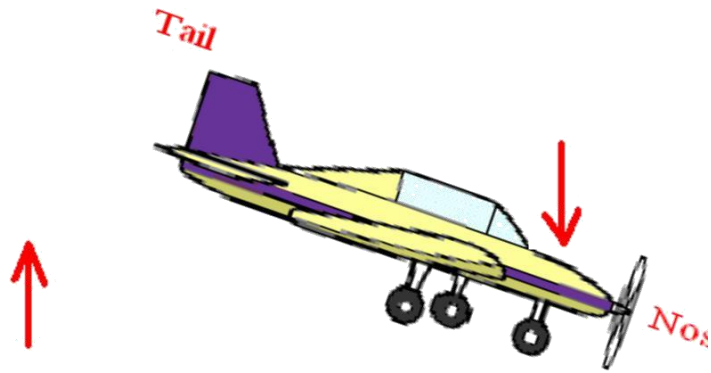

Fig.45

Case (iii): PROPELLER rotates in ANTICLOCKWISE direction when seen from rear end and Aeroplane turns towards LEFT



Fig.46

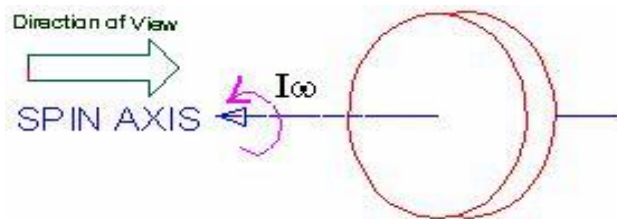

Fig.47

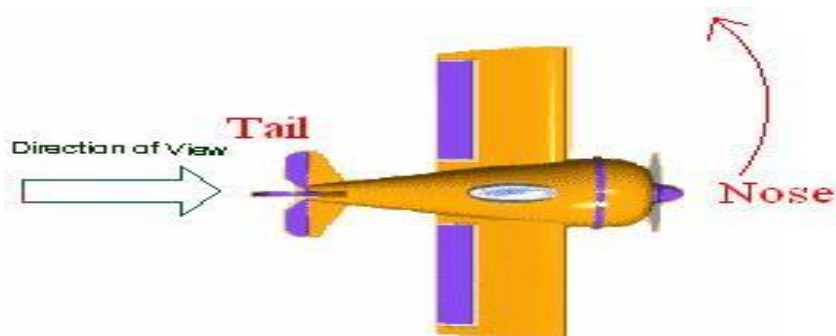

Fig.48

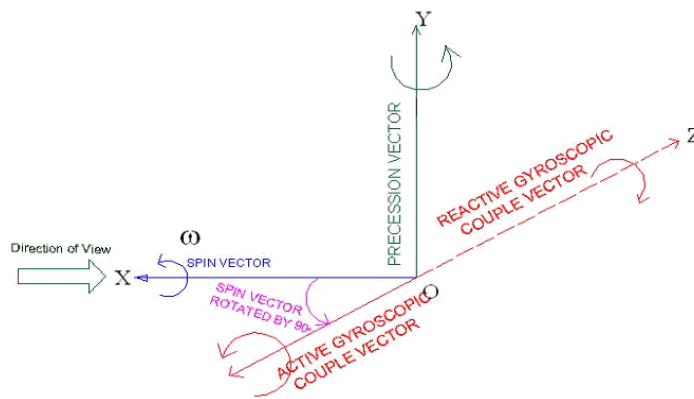

Fig.49

The analysis indicates, the reactive gyroscopic couple tends to **raise the tail** and **dip the nose** of aeroplane.

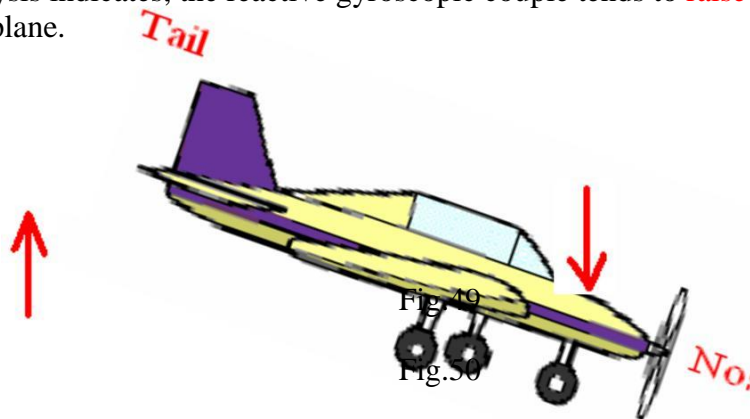

Fig. 50

Case (iv): **PROPELLER** rotates in **ANTICLOCKWISE** direction when seen from rear end and Aeroplane turns towards **RIGHT**



Fig.51

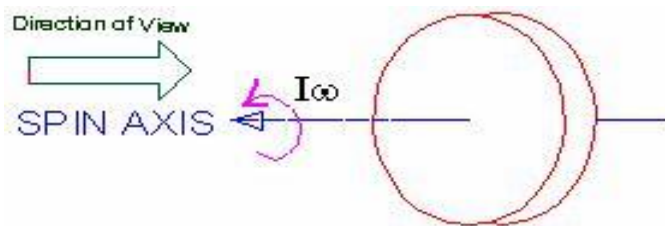

Fig.52

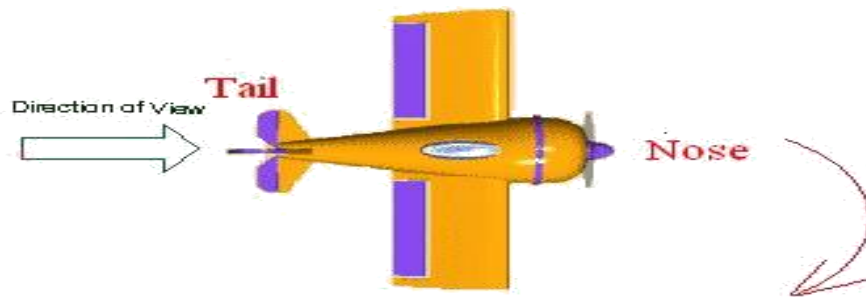

Fig.53

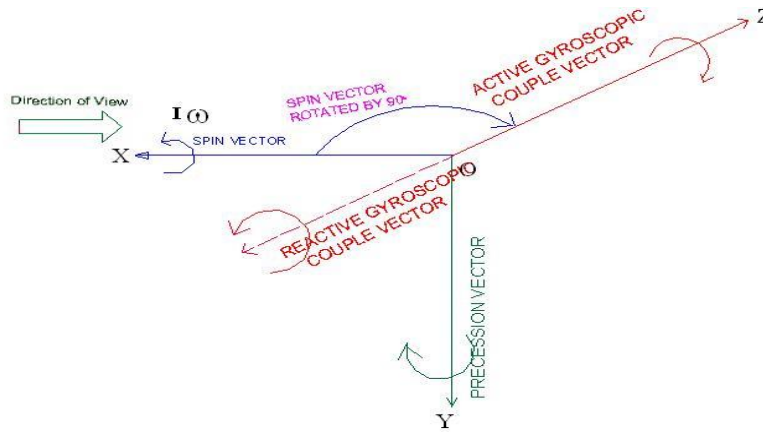

Fig.54

The analysis shows, the reactive gyroscopic couple tends to **raise the tail** and **dip the nose** of aeroplane.

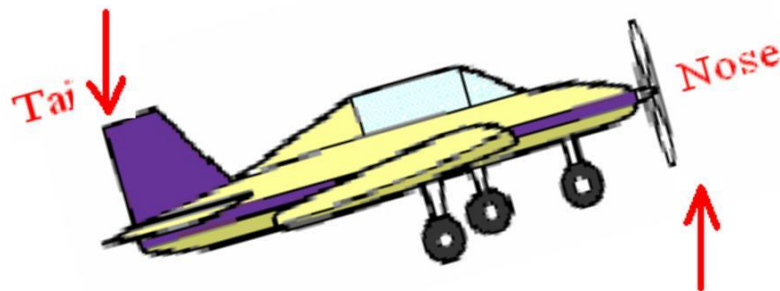

Fig.55

Case (v): PROPELLER rotates in **CLOCKWISE** direction when seen from rear end and Aeroplane takes off or nose move upwards



Fig.56

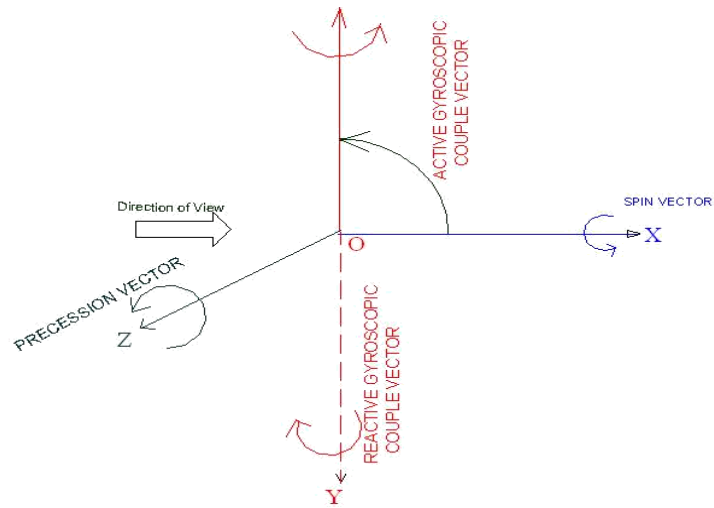

Fig.57

The analysis show, the reactive gyroscopic couple tends to turn the **nose** of aeroplane **toward right**

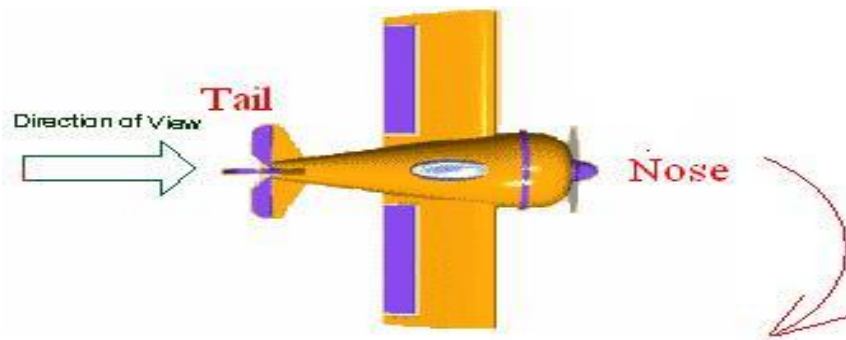

Fig.58

Case (vi): **PROPELLER** rotates in **CLOCKWISE** direction when seen from rear end and Aeroplane is **landing** or **nose** move **downwards**



Fig.59

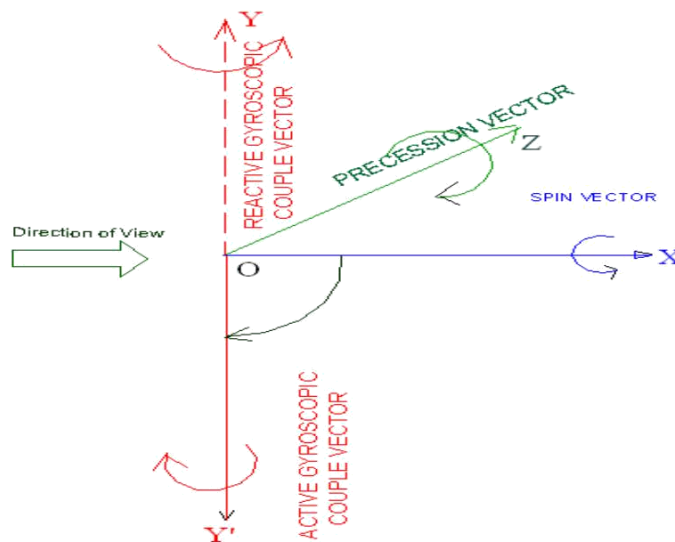
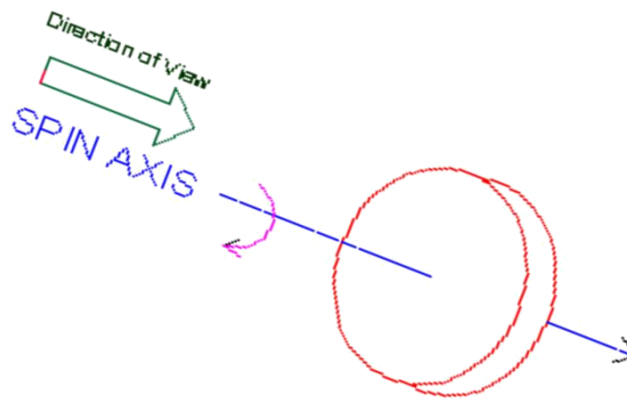

Fig. 61

The reactive gyroscopic couple tends to turn the **nose** of aeroplane **toward left**

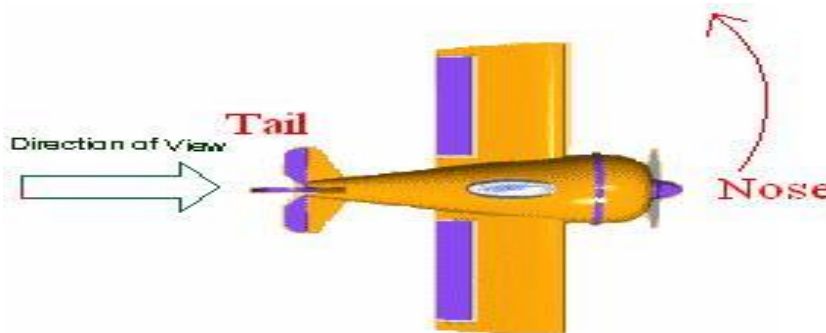

Fig.62

Case (vii): PROPELLER rotates in ANTICLOCKWISE direction when seen from rear end and Aeroplane **takes off** or **nose move upwards**

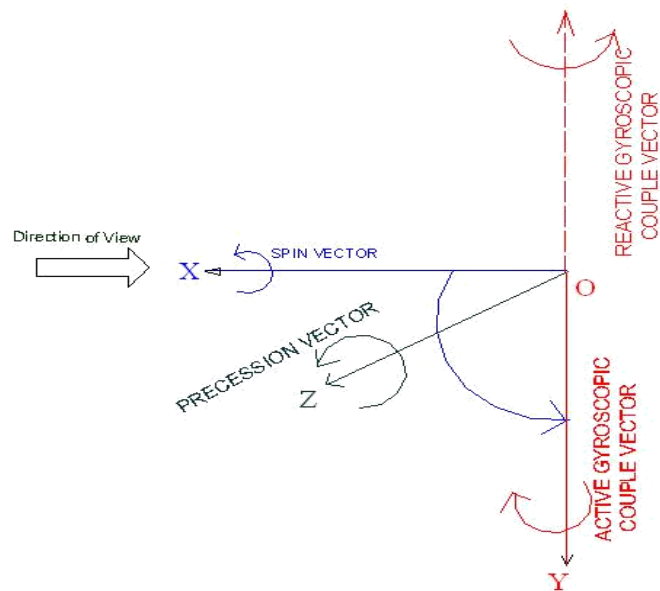

Fig.63

The reactive gyroscopic couple tends to turn the **nose** of aeroplane **toward left**

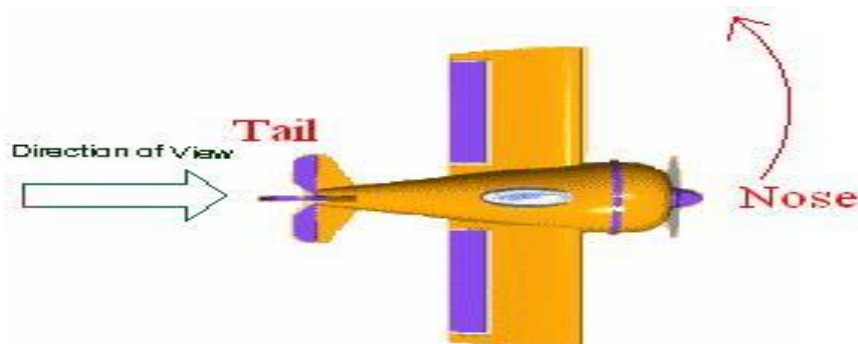

Fig.64

Case (viii): PROPELLER rotates in **ANTICLOCKWISE** direction when seen from rear end and Aeroplane **is landing** or **nose move downwards**

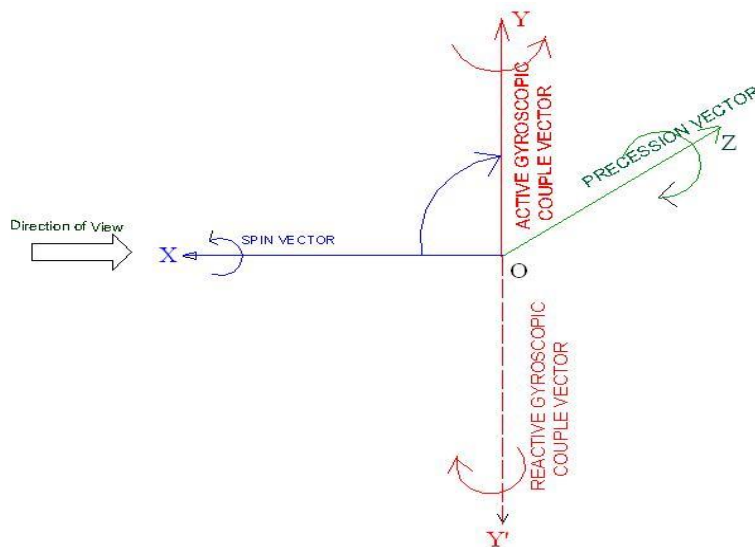

Fig.65

The analysis show, the reactive gyroscopic couple tends to turn the **nose** of aeroplane **toward right**

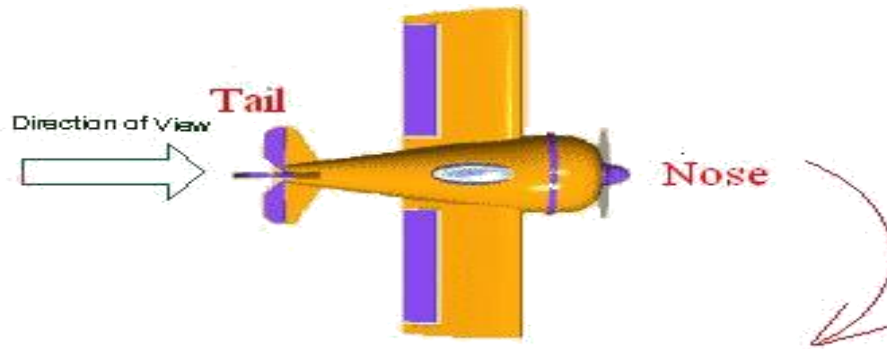

Fig.66

Problem 4

An aeroplane flying at a speed of 300 kmph takes **right turn** with a radius of 50 m. The mass of engine and propeller is 500 kg and radius of gyration is 400 mm. If the engine runs at 1800 rpm in **clockwise direction when viewed from tail end**, determine the gyroscopic couple and state its effect on the aeroplane. What will be the effect if the aeroplane turns to its **left** instead of right?

Solution Angular velocity of aeroplane engine:

$$\omega = \frac{2\pi N}{60} = \frac{2\pi \times 1800}{60} = 188.49 \text{ rad/s}$$

Angular velocity of precession: $\omega_p = \frac{V}{R}$

or
$$\omega_p = \frac{300 \times 1000}{3600} \times \frac{1}{50}$$

$$= 1.67 \text{ rad/s}$$

Moment of inertia:
$$I = mk^2 = 500 \times 0.4^2$$

$$= 80 \text{ kg m}^2$$

Gyroscopic couple:
$$c = I\omega\omega_p$$

$$= 80 \times 188.49 \times 1.67$$

$$= 25182.26 \text{ Nm}$$

Ans.

Case (i): PROPELLER rotates in CLOCKWISE direction when seen from rear end and Aeroplane turns towards RIGHT



Fig.67

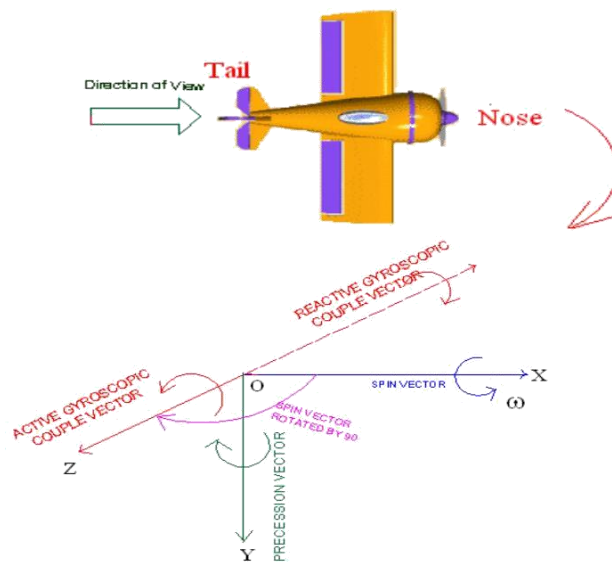

Fig.68

According to the analysis, the reactive gyroscopic couple tends to **dip the nose** and **raise the tail** of the aeroplane.

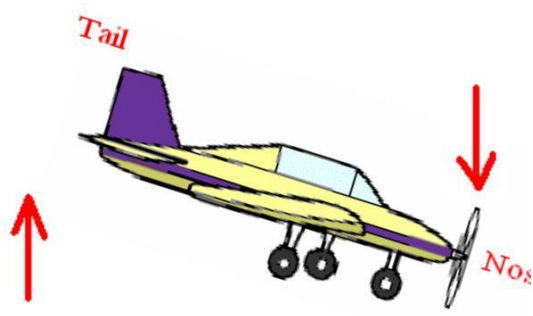

Fig.69

When aeroplane **turns to its left**, the magnitude of gyrocouple remains the same. However, the direction of reaction couple is reversed and it will **raise the nose** and **dip the tail** of the aeroplane.

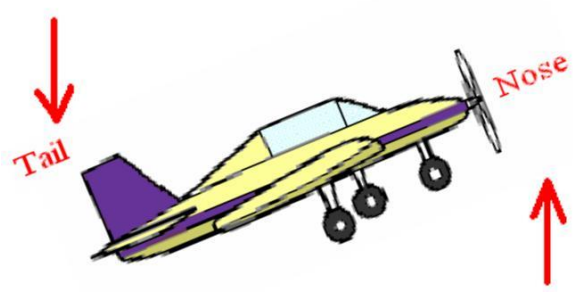

Fig.70

3.5 Stability of Automotive Vehicle

A vehicle running on the road is said to be stable when no wheel is supposed to leave the road surface. In other words, the resultant reactions by the road surface on wheels should act in upward direction. For a moving vehicle, one of the reaction is due to gyroscopic couple

produced by the rotating wheels and rotating parts of the engine. Let us discuss stability of two and four wheeled vehicles when negotiating a curve/turn.

Stability of Two Wheeler negotiating a turn



Fig.71

Fig. 71 shows a two wheeler vehicle taking **left turn** over a curved path. The vehicle is inclined to the vertical for equilibrium by an angle θ known as angle of heel.

Let

m = Mass of the vehicle and its rider in kg,

W = Weight of the vehicle and its rider in newtons = $m.g$,

h = Height of the centre of gravity of the vehicle and rider, r_w = Radius of the wheels,

R = Radius of track or curvature,

I_w = Mass moment of inertia of each wheel,

I_E = Mass moment of inertia of the rotating parts of the engine,

ω_w = Angular velocity of the wheels,

ω_E = Angular velocity of the engine rotating parts,

G = Gear ratio = ω_E / ω_w ,

v = Linear velocity of the vehicle = $\omega_w \times r_w$,

θ = Angle of heel. It is inclination of the vehicle to the vertical for equilibrium.

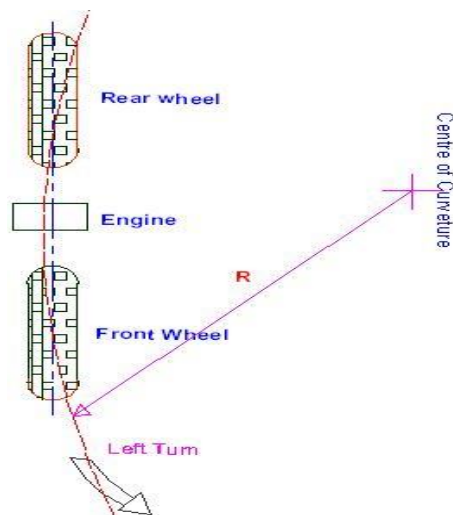

Fig.7
2

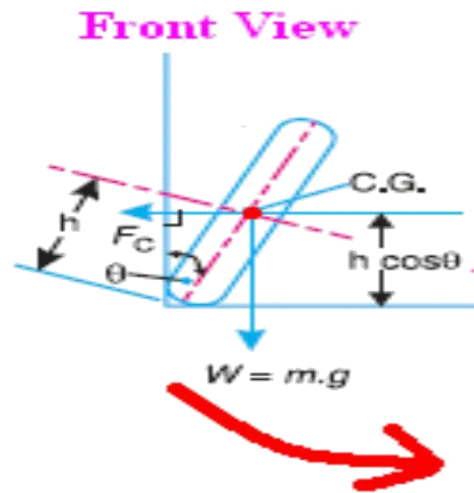

Fig.73

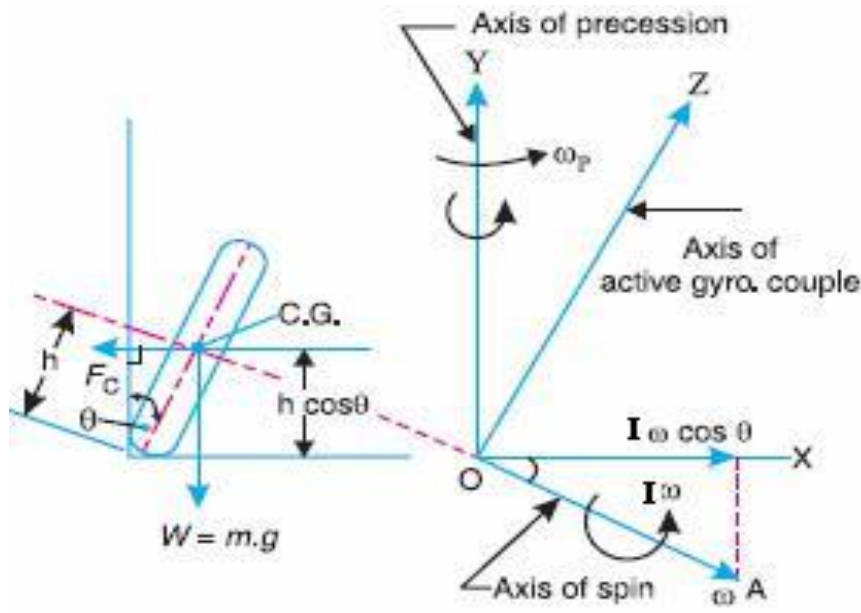

Fig.74

Let us consider the effect of the gyroscopic couple and centrifugal couple on the wheels.

1. Effect of Gyroscopic Couple

We know that,

$$V = \omega_W \times r_W$$

$$\omega_E = G \cdot \omega_W \text{ or } \omega_E = G \cdot v / r_W$$

Angular momentum due to wheels = $2 I_w \omega_W$

Angular momentum due to engine and transmission = $I_E \omega_E$

Total angular momentum ($I x \omega$) = $2 I_w \omega_W \pm I_E \omega_E$

$$= 2 I_w \frac{v}{r_w} \pm I_E G \frac{v}{r_w}$$

$$= \frac{v}{r_w} (2I_w \pm GI_E)$$

Also, Velocity of precession = $\omega_p = \frac{V}{R}$

It is observed that, when the wheels move over the curved path, the vehicle is always inclined at an angle θ with the vertical plane as shown in Fig... This angle is known as 'angle of heel'. In other words, the axis of spin is inclined to the horizontal at an angle θ , as shown in Fig.73 Thus, the angular momentum vector $I \omega$ due to spin is represented by OA inclined to OX at an angle θ . But, the precession axis is in vertical. Therefore, the spin vector is resolved along OX.

Gyroscopic Couple,

$$C_g = (I\omega) \cos\theta \times \omega_p$$

$$C_g = \frac{v^2}{Rr_w} (2I_w \pm GI_E) \cos\theta$$

Note: When the engine is rotating in the same direction as that of wheels, then the positive sign is used in the above equation. However, if the engine rotates in opposite direction to wheels, then negative sign is used.

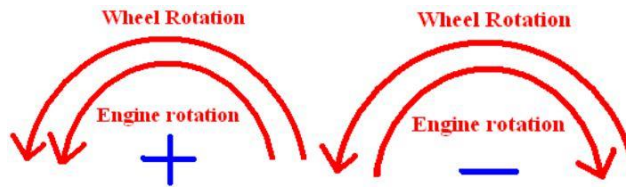

The gyroscopic couple will act over the vehicle outwards i.e., in the anticlockwise direction when seen from the front of the two wheeler. **This couple tends to overturn/topple the vehicle in the outward direction as shown in Fig...**

Analysis:

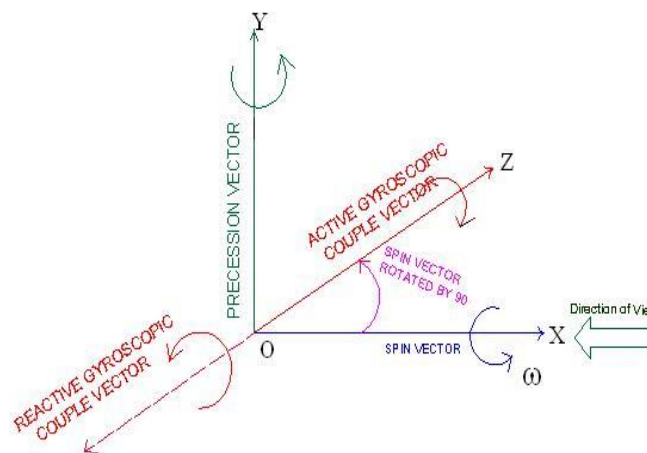

Fig.75

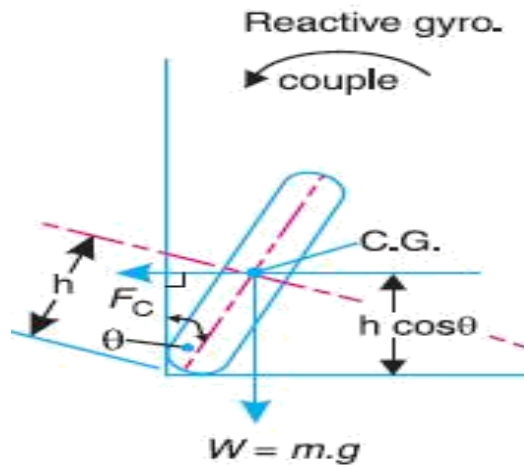

Fig.7
6

2. Effect of Centrifugal Couple

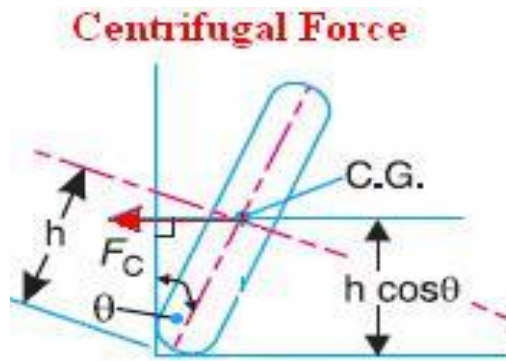

Fig. 77

We have,

Centrifugal force,

$$F_c = \frac{mv^2}{R}$$

or

Centrifugal Couple,

$$C_c = F_c \times h \cos \theta$$

$$= \frac{mv^2}{R} h \cos \theta$$

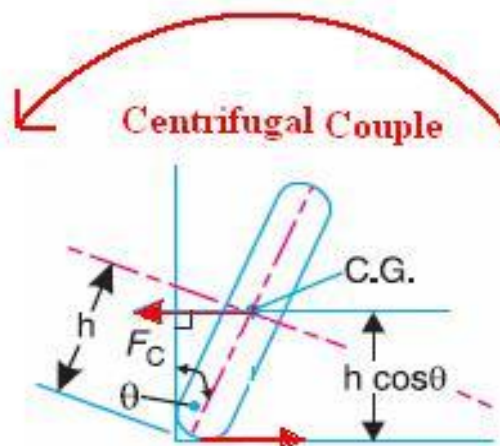

The Centrifugal couple will act over the two wheelers outwards i.e., in the anticlockwise direction when seen from the front of the two wheeler. This couple tends to overturn/topple the vehicle in the outward direction as shown in Fig.78

Therefore, the total Over turning couple: $C = C_g + C_c$

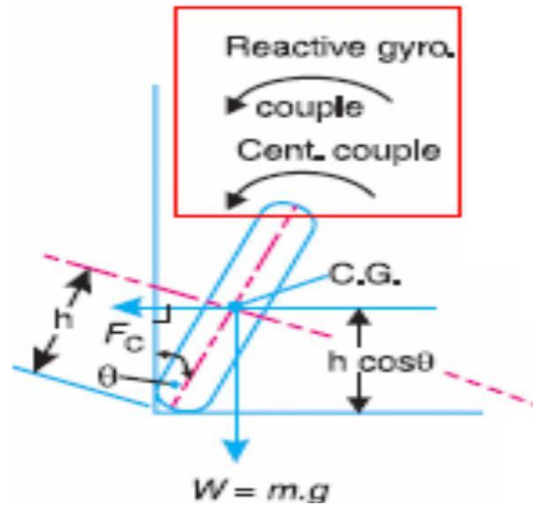

Fig.79

$$C = \frac{v^2}{Rr} (2I_w + GI_e) \cos\theta + \frac{mv^2}{R} h \cos\theta$$

For the vehicle to be in equilibrium, overturning couple should be equal to balancing couple acting in clockwise direction due to the weight of the vehicle and rider.

□

$$C = mgh \sin\theta$$

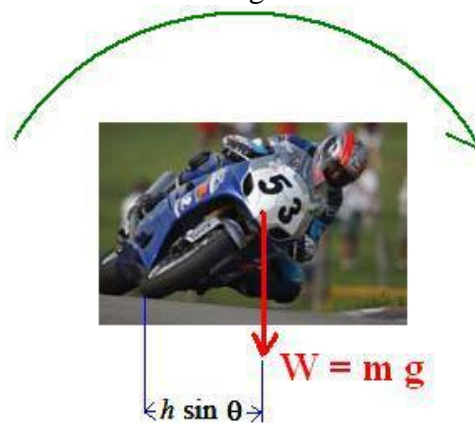

Fig.80

For the stability, overturning couple must be equal to balancing couple,

$$\frac{v^2}{Rr_w} (2I_w + GI_e) \cos\theta + \frac{mv^2}{R} h \cos\theta = mgh \sin\theta$$

Therefore, from the above equation, the value of angle of heel (θ) may be determined, so that the vehicle does not skid. Also, for the given value of θ , the maximum vehicle speed in the turn with out skid may be determined.

Problem 5

A motorcycle and its rider together weighs 2000 N and their combined centre of gravity is 550 mm above the road when motorcycle is upright. Each wheel is of 580 mm diameter and has a moment of inertia of 1.0 kgm^2 . The moment of inertia of rotating parts of engine is 0.15 kg m^2 . The engine rotates at 5 times the speed of the vehicle and the same sense. Determine the angle of heel necessary when motorcycle is taking a turn over a track of 35 m radius at a speed of 60 kmph.

Solution:

Velocity of vehicle :

$$v = \frac{60 \times 1000}{3600} = 16.67 \text{ m/s}$$

Angular velocity of wheel:

$$\omega = \frac{2v}{d} = \frac{2 \times 16.67}{0.58} = 57.48 \text{ rad/s}$$

Angular velocity of precession: $\omega_p = \frac{v}{R} = \frac{16.67}{35} = 0.476 \text{ rad/s}$

(i) Gyroscopic couple due to two wheels:

$$C_w = 2I_w \omega \omega_p \cos\theta$$

$$= 2 \times 1.0 \times 57.48 \times 0.476 \times \cos\theta$$

$$= 54.72 \cos\theta \text{ Nm}$$

= Gyroscopic couple due to rotating parts of engine:

$$C_E = I_E G \omega \omega_p \cos\theta$$

$$= 0.15 \times 5 \times 57.48 \times 0.476 \times \cos\theta$$

$$= 20.52 \cos\theta \text{ Nm}$$

ii) Centrifugal force due to angular velocity of die wheel:

$$F_c = \frac{mv^2}{R} = \frac{2000 \times 16.67^2}{9.81 \times 35} = 1618.7 \text{ N}$$

Centrifugal couple:

$$C_c = 1618.7 \times 0.55 \cos\theta$$

$$= 890.28 \cos\theta \text{ Nm}$$

Total overturning couple:

$$C = C_w + C_e + C_c$$

$$= T(54.72 + 20.52 + 890.28) \cos\theta$$

$$= T 965.52 \cos\theta \text{ Nm}$$

Balancing couple = $mgh \sin\theta$

$$= \frac{2000}{9.81} \times 9.81 \times 0.55 \sin\theta$$

$$= 1100 \sin\theta \text{ Nm}$$

For the stability of motorcycle, overturning couple should be equal to resisting couple.

$$1100 \sin\theta = 965.52 \cos\theta$$

or

$$\tan\theta = \frac{965.52}{1100} = 0.877$$

$$\text{heel angle: } \theta = 41.27^\circ$$

Problem 6

A motor cycle with its rider has a mass of 300 kg. The centre of gravity of the machine and rider combined being 0.6 m above the ground with machine in vertical position. Moment of inertia of each wheel is 0.525 kg m^2 and the rolling diameter of 0.6 m. The engine rotates 6 times the speed of the road wheels and in the same sense. The engine rotating parts have a mass moment of inertia of 0.1686 kg m^2 . Find (i) the angle of heel necessary if the vehicle is running at 60 km/hr round a curve of 30 m (ii) If the road and tyre friction allow for the angle of heel not to exceed 50° , what is the maximum road velocity of the motor cycle.

Solution:

$m = 300 \text{ kg}$, $h = 0.6 \text{ m}$, $I_w = 0.525 \text{ kg m}^2$, $d_w = 0.6 \text{ m}$; $r_w = 0.3 \text{ m}$, $G = 6$, $I_E = 0.1686 \text{ m}^2$, $V = 60 \text{ km/hr} = 16.66 \text{ m/s}$, $R = 30 \text{ m}$ (i) $\theta = ?$ (ii) $\theta = 50^\circ$ $V = ?$

1. Angle of heel,

We have,

$$\frac{v^2}{Rr_w} (2I_w + GI_e) \cos \theta + \frac{mv^2}{R} h \cos \theta = mgh \sin \theta$$

$$\therefore \frac{16.66^2}{30} \left[\frac{2 \times 0.525 + 6 \times 0.1685}{0.3} + 300 \times 0.6 \right] \cos \theta = 300 \times 9.81 \times 0.6 \times \sin \theta$$

$$\theta = 45^\circ$$

A) Given, $\theta = 50^\circ$, $V = ?$,

$$\frac{v^2}{Rr_w} (2I_w + GI_e) \cos \theta + \frac{mv^2}{R} h \cos \theta = mgh \sin \theta$$

$$\therefore \frac{V^2}{30} \left[\frac{2 \times 0.525 + 6 \times 0.1685}{0.3} + 300 \times 0.6 \right] \cos 50 = 300 \times 9.81 \times 0.6 \times \sin 50$$

$$\therefore V = 66 \text{ Kmph}$$

Stability of Four Wheeled Vehicle negotiating a turn.



Stable condition



Unstable Condition

Fig.81

Consider a four wheels automotive vehicle as shown in Figure 82. The engine is mounted at the rear with its crank shaft parallel to the rear axle. The centre of gravity of the vehicle lies vertically above the ground where total weight of the vehicle is assumed to be acted upon.

Let

$m =$ Mass of the vehicle (kg)

$W =$ Weight of the vehicle (N) = $m.g$,

$h =$ Height of the centre of gravity of the vehicle (m)

$r_w =$ Radius of the wheels (m)

$R =$ Radius of track or curvature (m)

$I_w =$ Mass moment of inertia of each wheel ($kg\cdot m^2$)

$I_E =$ Mass moment of inertia of the rotating parts of the engine ($kg\cdot m^2$)

$\omega_w =$ Angular velocity of the wheels

(rad/s) $\omega_E =$ Angular velocity of the engine

(rad/s)

$G =$ Gear ratio = ω_E / ω_w ,

$v =$ Linear velocity of the vehicle (m/s) = $\omega_w \times$

r_w , $x =$ Wheel track (m)

$b =$ Wheel base (m)

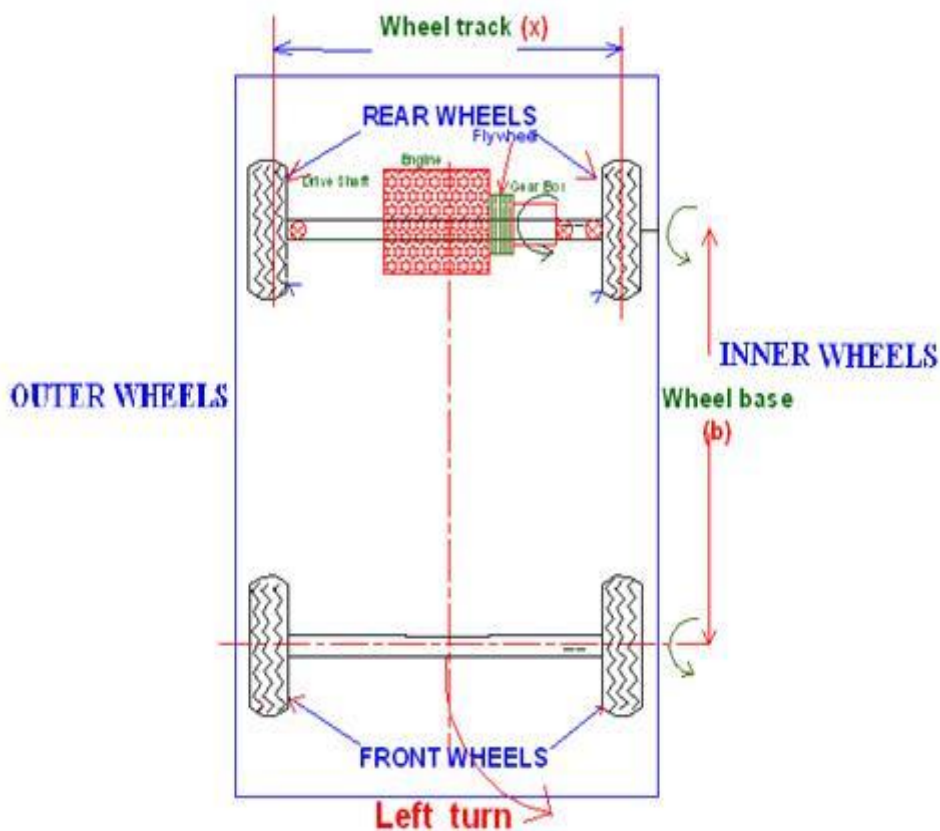

Fig.82

1. Reaction due to weight of Vehicle

Weight of the vehicle. Assuming that weight of the vehicle (mg) is equally distributed over four wheels. Therefore, the force on each wheel acting downward is $mg/4$ and the reaction by the road surface on the wheel acts in upward direction.

$$R_w = \frac{mg}{4}$$

x Effect of Gyroscopic couple due to Wheel

Gyroscopic couple due to four wheels is,

$$C_w = 4 I_w \omega \dot{\phi}$$

(iii) Effect of Gyroscopic Couple due to Engine

Gyroscopic couple due to rotating parts of the engine

$$C_E = I_E \omega \dot{\phi} = I_E G \dot{\phi}$$

Therefore, Total gyroscopic couple:

$$C_g = C_w + C_E = \omega \dot{\phi} (4I_w \pm I_E G)$$

When the wheels and rotating parts of the engine rotate in the same direction, then positive sign is used in the above equation. Otherwise negative sign should be considered.

Assuming that the vehicle takes a left turn, the reaction gyroscopic couple on the vehicle acts between outer and inner wheels.

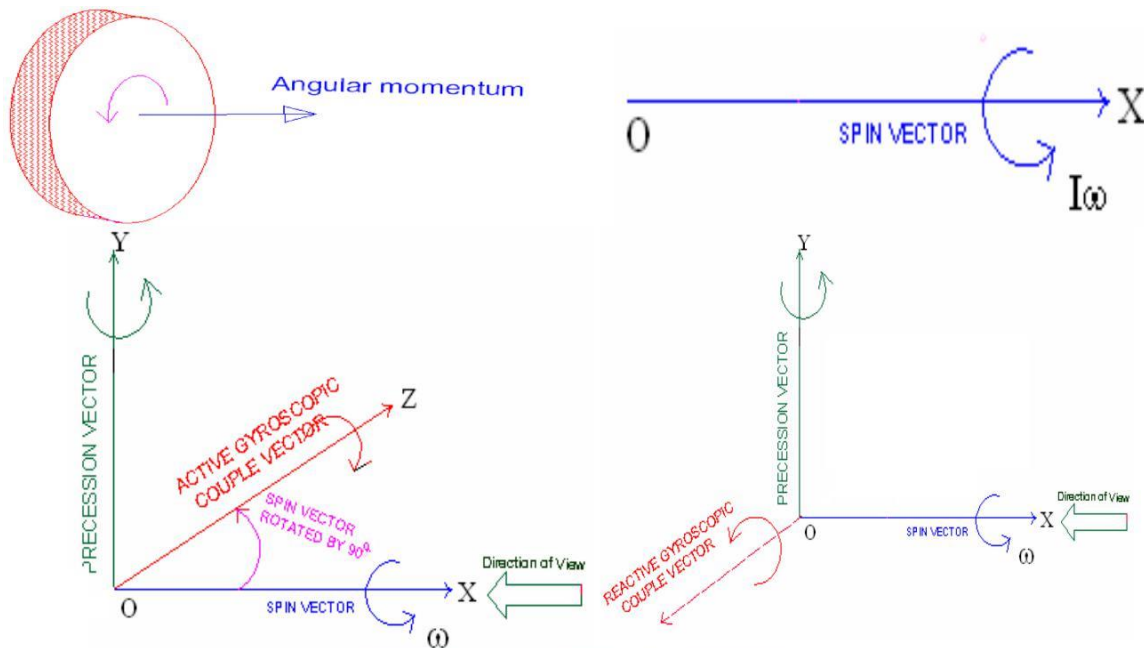

Fig.83

This gyroscopic couple tends to **press the outer** wheels and **lift the inner wheels**.

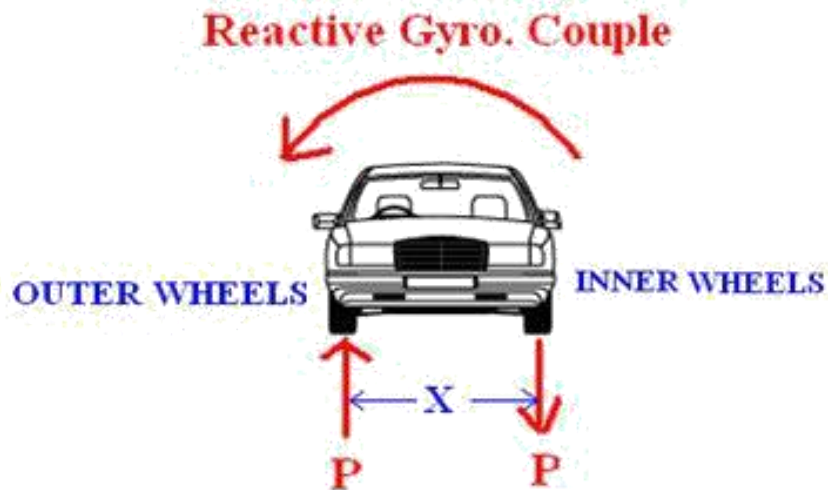

Fig.84

Due to the reactive gyroscopic couple, vertical reactions on the road surface will be produced. **The reaction will be vertically upwards on the outer wheels** and **vertically downwards on the inner wheels**. Let the magnitude of this reaction at the two outer and inner wheels be P Newtons, then,

$$P \times X = C_{gr}$$

$$P = \frac{C_{gr}}{X}$$

Road reaction on each outer/Inner wheel,

$$\frac{P}{2} = \frac{C_g}{2X}$$

Effect of Centrifugal Couple

When a vehicle moves on a curved path, a centrifugal force acts on the vehicle in outward direction through the centre of gravity of the vehicle(Fig...)

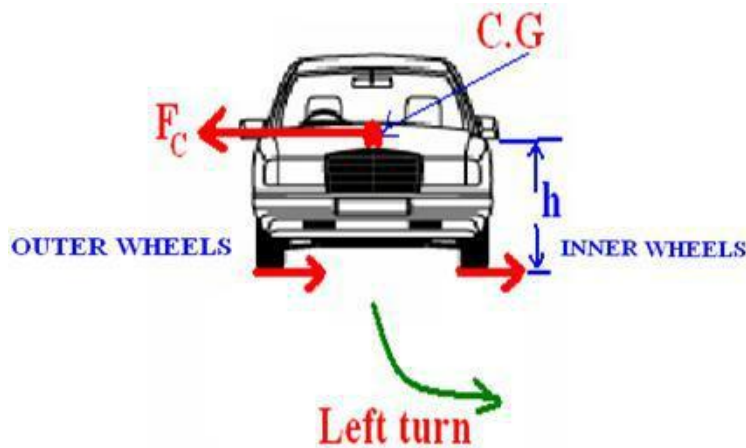

Fig.85

Centrifugal force,

$$F_c = m\omega_p^2 R = \frac{mv^2}{R}$$

This force forms a Centrifugal couple.

$$C_c = \frac{mv^2 h}{R}$$

This centrifugal couple tends to press the outer and lift the inner



Fig.86

Due to the centrifugal couple, vertical reactions on the road surface will be produced. The reaction will be vertically upwards on the outer wheels and vertically downwards on the inner wheels. Let the magnitude of this reaction at the two outer and inner wheels be F Newtons, then,

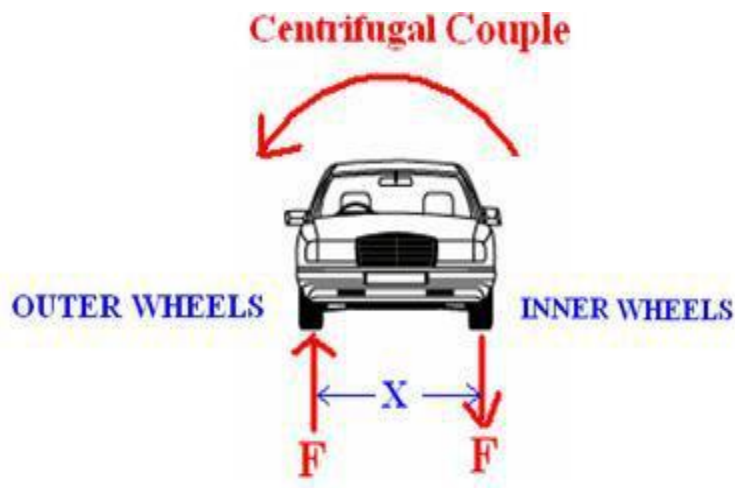

Fig.87

Road reaction on each outer/Inner wheel,

$$\frac{F}{2} = \frac{C_c}{2X}$$

The reactions on the outer/inner wheels are as follows,

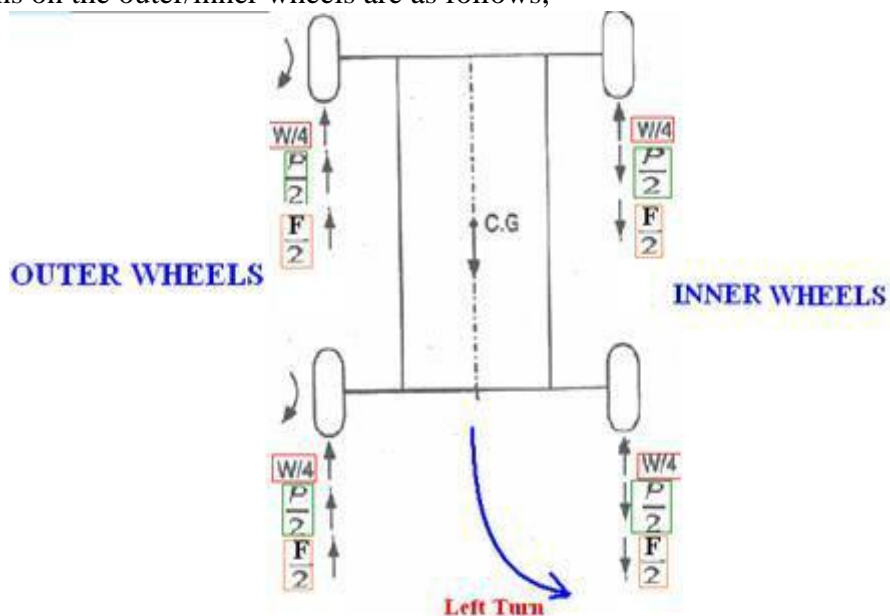

Fig.88

Total vertical reaction at each outer wheels

$$P_o = \frac{W}{4} + \frac{P}{2} + \frac{Q}{2}$$

Total vertical reaction at each inner wheels

$$P_i = \frac{W}{4} - \frac{P}{2} - \frac{Q}{2}$$

Problem 7

An automobile car is travelling along a track of 100 m mean radius. The moment of inertia of 500 mm diameter wheel is 1.8 kg m^2 . The engine axis is parallel to the rear axle and crank shaft rotates in the same sense as the wheel. The moment of inertia of rotating parts of the engine is 1 kg m^2 . The gear ratio is 4 and **the mass of the vehicle is 1500 kg**. If the centre of gravity of the vehicle is 450 mm above the road level and width of the track of the vehicle is 1.4 m, determine the limiting speed of the vehicle for condition that all four wheels maintain contact with the road surface.

Solution Let v = limiting velocity of the vehicle.

Angular velocity: $\omega = \frac{v}{r} = \frac{v}{0.25} \text{ rad/s}$

Precession velocity: $\omega_p = \frac{v}{R} = \frac{v}{100} \text{ rad/s}$

(i) Reaction due to gyroscopic couple:

(a) Gyroscopic couple due to four wheels:

$$\begin{aligned} C_w &= 4I_w\omega\omega_p \\ &= 4 \times 2 \times \frac{v}{0.25} \times \frac{v}{100} = 0.32 v^2 \text{ Nm} \end{aligned}$$

(b) Gyroscopic couple due to engine parts:

$$\begin{aligned} C_e &= I_e G \omega \omega_p \\ &= 1 \times 4 \times \frac{v}{0.25} \times \frac{v}{100} = 0.16 v^2 \text{ Nm} \end{aligned}$$

Total gyroscopic couple:

$$\begin{aligned} C_g &= C_w + C_e \\ &= 0.32v^2 + 0.16v^2 = 0.48v^2 \text{ Nm} \end{aligned}$$

Reaction due to total gyroscopic couple on each outer wheel:

$$R_g = \frac{C_g}{2b} = \frac{0.48v^2}{2 \times 1.5} = 0.16 v^2 \text{ N} (\uparrow)$$

Reaction due to total gyroscopic couple on each inner wheel:

$$C_g = 0.16 v^2 N (\downarrow)$$

(ii) Reaction due to centrifugal couple:

Centrifugal force:
$$F_c = \frac{mv^2}{R} = \frac{1500 \times v^2}{100} = 15v^2 N$$

Overturning couple due to centrifugal force:

$$\begin{aligned} C_c &= F_c \times h \\ &= 15 v^2 \times 0.45 = 6.75 v^2 \text{ Nm} \end{aligned}$$

Vertical downward reaction on each inner wheel is:

$$R_c = \frac{C_c}{2b} = \frac{6.75 v^2}{2 \times 1.5} = 2.25 v^2 N (\downarrow)$$

(iii) Reaction due to weight of the vehicle:

$$R_w = \frac{mg}{4} = \frac{1500 \times 9.81}{4} = 3678.75 N (\uparrow)$$

The limiting condition to avoid lifting of inner wheels from the road surface is:

or
$$R_i = R_w - R_c - R_g > 0$$

$$R_w > R_c + R_g$$

$$3678.75 \geq 2.25v^2 + 0.16 v^2$$

$$v = 39.07 \text{ m/s, or } 140.65 \text{ kmph}$$

or

Problem 8

A four wheeled motor vehicle of mass 2000 kg has a wheel base of 2.5 m, track width 1.5m and height of c.g is 500 mm above the ground level and lies 1 m from the front axle. Each wheel has an effective diameter of 0.8m and a moment of inertia of 0.8 kgm². The drive shaft, engine flywheel rotating at 4 times the speed of road wheel in clockwise direction when viewed from the front and is equivalent to a mass of 75 kg having a radius of gyration of 100mm. If the vehicle is taking a right turn of 60 m radius at 60kmph, determine the load on each wheel.

Solution,

Since the C.G of the vehicle is 1 m from the front,

$$\begin{aligned} \text{The percentage of weight on the front wheels} &= (2.5-1)/2.5 \times 100 \\ &= 60\% \end{aligned}$$

The percentage of weight on the rear wheels = 40 %

Total weight on the front wheels = 11772 N

Total weight on the rear wheels = 7848 N

Weight on each of front wheel = 5886 N = $W_F/2$

Weight on each of rear wheel = 3924 N = $W_R/2$

The road reaction due to weight of the vehicle is always upwards

Effect of Gyroscopic couple due to Wheel,

$$C_W = 4I_W \cdot \omega_w \cdot \omega_p$$

$$= 37.1 \text{ Nm}$$

Gyroscopic couple due to wheels acts between outer and inner wheels.

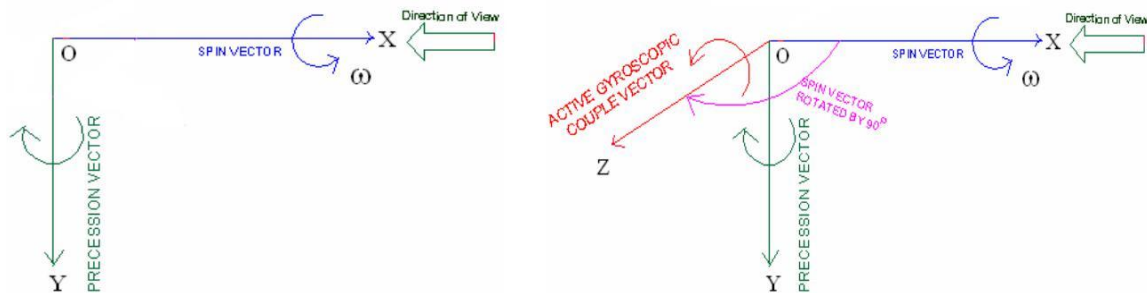

Fig.89

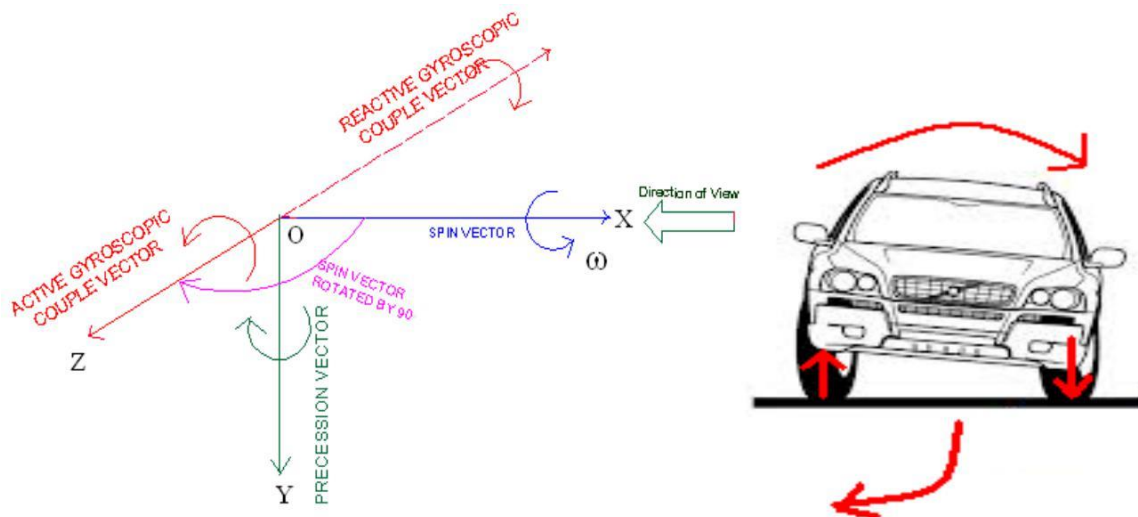

Fig.90

The gyroscopic couple tends to press the outer and lift the inner wheels

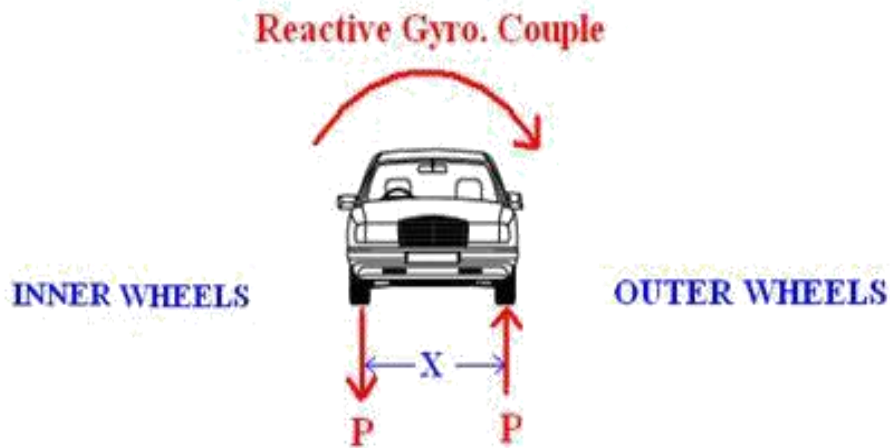

Fig. 91

The road reaction is vertically upward for outer wheels and downward for inner wheels

Road reaction on each outer/Inner wheel,

$$\frac{P}{2} = \frac{C_w}{2X} = 12.37 \text{ N}$$

Effect of Gyroscopic Couple due to Engine

Gyroscopic couple due to engine

$$\begin{aligned} C_E &= I_E \cdot \omega_E \cdot \omega_P \\ C_E &= I_E \cdot G \cdot \omega_W \cdot \omega_P \\ &= 34.7 \text{ N m} \end{aligned}$$

Gyroscopic couple due to engine acts between Front and Rear wheels.

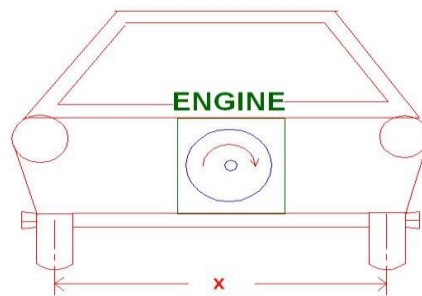

Fig. 92

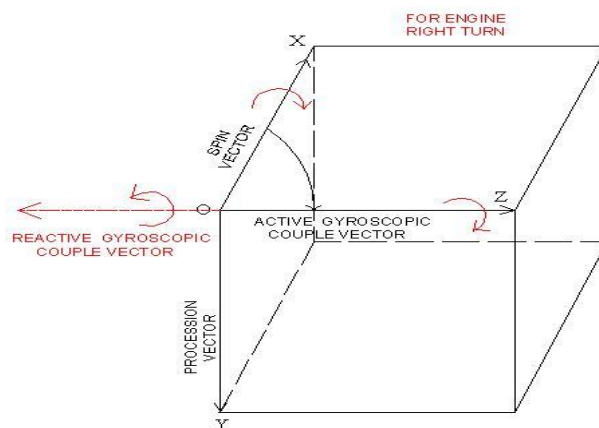

Fig. 93

The couple tends to press Rear wheels and Lift front wheels

Reactive Gyroscopic couple



Fig. 94

The road reaction is vertically upward for REAR and downward for FRONT wheels.

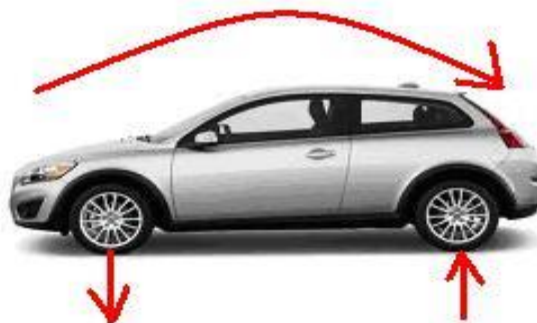

Fig.95

Road reaction on each Front/Rear wheels

$$\frac{Q}{2} = \frac{C_E}{2b} = 6.94 \text{ N}$$

Effect of Centrifugal Couple

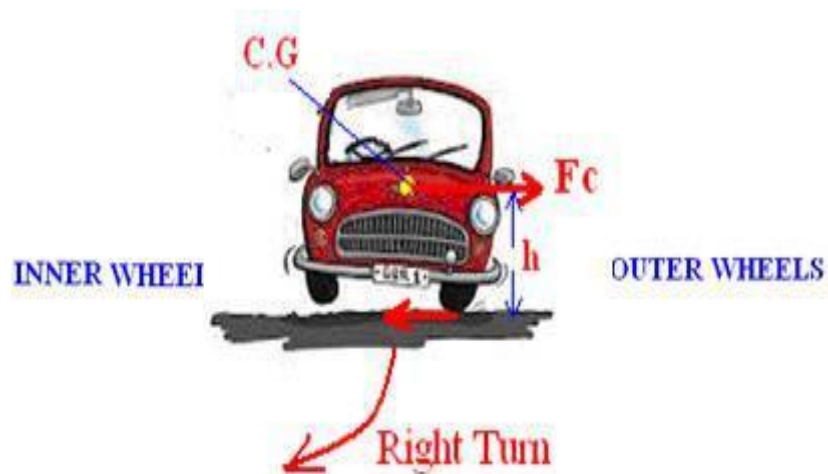

Fig.96

$$\text{Centrifugal force, } F_c = \frac{MV^2}{R} = 9263 \text{ N}$$

$$\text{Centrifugal Couple } C_c = \frac{mV^2}{R} \times h = 4631.5 \text{ N}$$

The gyroscopic couple tends to press the outer and lift the inner wheels.



Fig.97

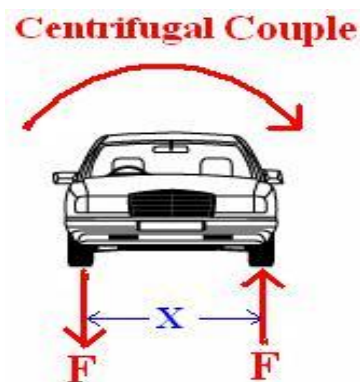

Fig. 98

The road reaction is vertically upward for outer wheels and downward for inner wheels. Road reaction on each outer/Inner wheel

$$\frac{F}{2} = \frac{C_c}{2X} = 1543.8 \text{ N}$$

Engine crank shaft rotates clockwise direction seen from front, and Vehicle takes RIGHT turn

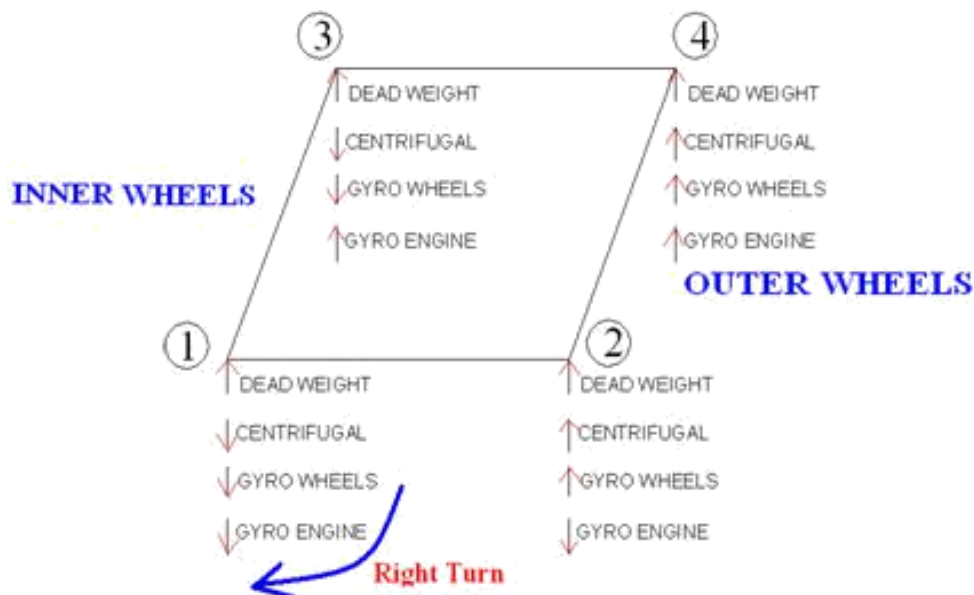

Fig.99

Load on front wheel 1 = 4322.86 N

Load on front wheel 2 = 7435.26 N

Load on rear wheel 3 = 2374.74 N

Load on rear wheel 4 = 5487.14 N

Problem 9

A section of an electric rail track of gauge 1.5 m has a left hand curve of radius 300 m, the superelevation of the outer rail being 260 mm. The approach to the curve is along a straight length of track, over the last 50 m there is a uniform increase in elevation of the outer rail from level track to the super elevation of 260 mm. Each motor used for traction has a rotor of mass 550 kg and radius of gyration 300 mm. The motor shaft is parallel to the axes of the running wheels. It is supported in bearings 780 mm apart and runs at four times the wheel speed but in opposite direction. The diameter of running wheel is 1.2 m. Determine the forces on the bearings due to gyroscopic action when the train is travelling at 90 kmph (a) on the last 50 m of approach track (b) on the curve track.

Solution Angular velocity:

$$\begin{aligned}\omega &= \frac{\text{Gear ratio} \times v}{r} \\ &= \frac{4 \times 90 \times 1000}{3600 \times 0.6} = 166.67 \text{ rad/s}\end{aligned}$$

Let ω_p = angular velocity of precession.

Moment of inertia: $I = mk^2 = 550 \times 0.3^2 = 49.5 \text{ kg m}^2$

Gyroscopic couple:

$$\begin{aligned}C &= I\omega\omega_p \\ &= 49.5 \times 166.67 \times \omega_p \\ &= 8250.16 \omega_p \text{ Nm} \\ P &= \frac{8250.16 \omega_p}{0.78} \\ &= 10577.1 \omega_p \text{ N}\end{aligned}$$

Forces on bearings:

(a) Angle turned by engine shaft in the last 50 m track

$$= \frac{0.26}{1.5} = 0.1734 \text{ rad}$$

Time taken to cover this distance $\frac{50}{90/3.6} = 2 \text{ sec}$

Velocity of precession: $\omega_p = \frac{0.1734}{2} = 0.0867$

Forces on bearings: $P = 10577.1 \times 0.0867 = 917.03 \text{ N}$

The change in momentum is represented by vector oa and ob as shown in Figure 15.18.

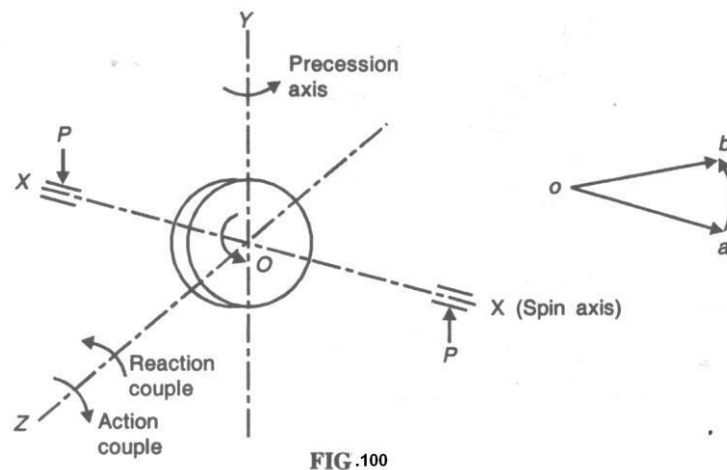

The couple required for precession is, therefore, acting in clockwise looking upward direction. The reaction couple acts in anticlockwise direction looking downward as the forces on the bearings are in the directions shown in Figure 100.

- i) When electric rail moves on curved path, the effective angular velocity of precession about the axis perpendicular to the axis of rotation is:

$$\omega_p = \frac{v}{R} \cos \theta$$

where θ is angle due to superelevation of outer rail. Referring to Figure 15.19.

$$\cos \theta = \frac{AB}{AC} = \frac{1.4773}{1.5} = 0.9848$$

or
$$\omega_p = \frac{90 \times 1000}{3600 \times 300} \times 0.9848 = 0.08206 \text{ rad/s}$$

Effective angular velocity of spin =

Therefore,

$$\begin{aligned} \text{Forces on bearings:} \quad P &= 10577.1 W_p \\ &= 10577.1 \times 0.08206 \\ &= 867.95 \text{ N} \end{aligned}$$

Ans.

The change in angular momentum vector and reaction couple shown in Figure 15.19 shows direction of forces on the bearings.

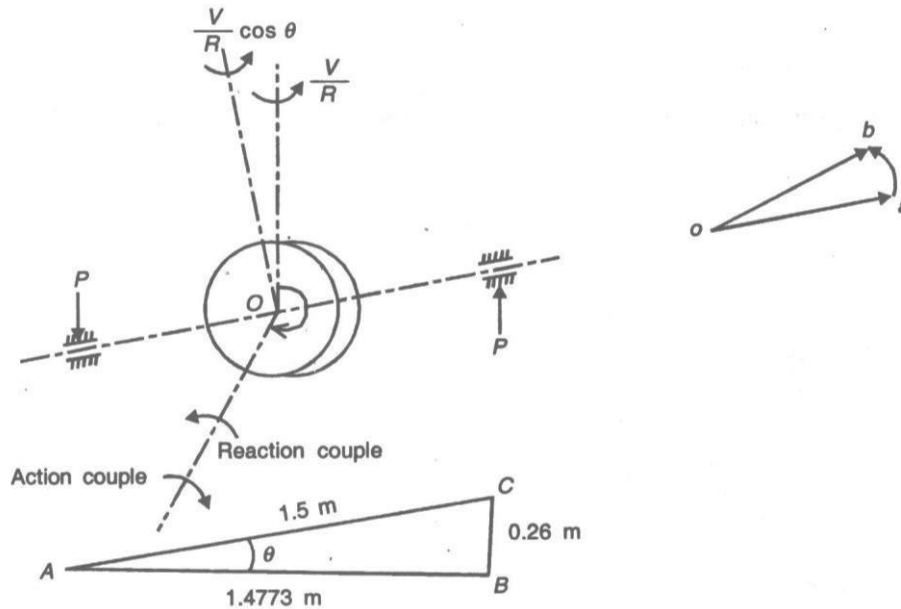

Fig.101

Problem 10.

A four wheeled trolley of total weight 20 kN running on rails of 1 m gauge rounds a curve of 30 m at 40 kmph on a track of embankment slope of 10° . The wheels have external diameter of 0.6 m and each pair of axle weighs 2000 N and has a radius of gyration of 0.25 m. The height of the C.G of trolley above the wheel is 1 m. Calculate the reaction on the each rail due to gyroscopic and centrifugal couple.

Solution,

$$\begin{aligned} \text{Weight of trolley} &= W = 20000 \text{ N} \\ \text{Wheel track} &= 2x \\ &= 1 \text{ m} \\ \text{Radius of curve} &= R = 30 \text{ m} \\ \text{Trolley velocity} &= 40 \text{ kmph} = 11.1 \text{ m/s} \\ \text{Track of embankment slope} &= \theta = 10^\circ \\ \text{Diameter of wheel} &= d = 0.6 \text{ m} \\ \text{Weight of each pair of wheels} &= W_1 = 2000 \text{ N} = mg \\ \text{Radius of gyration} &= k_g = 0.25 \text{ m} \\ \text{Height of C.G from wheel base} &= 1 \text{ m} \end{aligned}$$

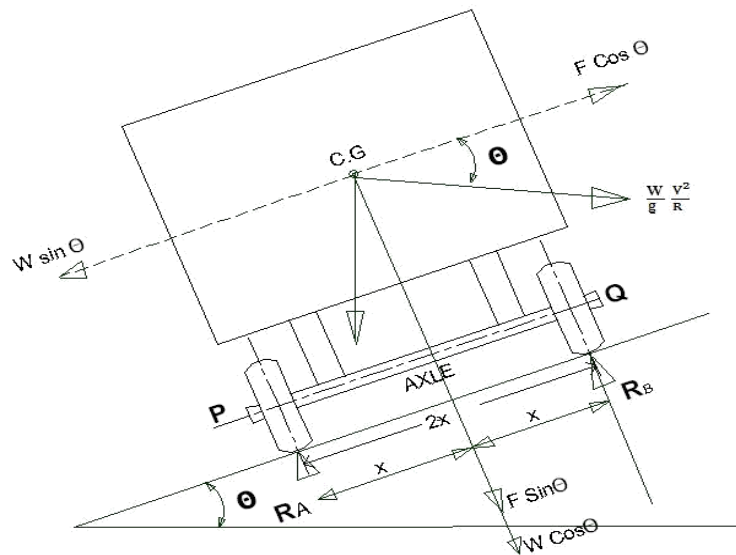

Fig.102

Referring to above Fig. 102,

Consider, the total effect of weight of trolley and that of centrifugal force F,

∴ The reaction RA and RB at the wheels X and Y,

Resolving forces perpendicular to the track,

$$\begin{aligned}
 R_A + R_B &= mg \cos \theta + F \sin \theta \\
 &= mg \cos \theta + m \frac{v^2}{R} \sin \theta \\
 &= mg \left(\cos \theta + \frac{v^2}{gR} \sin \theta \right) \\
 &= 20000 \left[0.9848 + \frac{11.1^2}{9.81 \times 30} * 0.1736 \right] \\
 R_A + R_B &= 21.158 \text{ N}
 \end{aligned}$$

Taking moments about Q,

$$R_A * 2x = (F \sin \theta + mg \cos \theta) x - (F \cos \theta + mg \sin \theta) h$$

$$\begin{aligned}
 R_A &= \frac{\left(\frac{mv^2}{R} \sin \theta + mg \cos \theta \right)}{2} - \frac{h}{2x} \left(\frac{mv^2}{R} \cos \theta - mg \sin \theta \right) \\
 &= \frac{mg \left(\frac{v^2}{gR} \sin \theta + \cos \theta \right)}{2} - \frac{hmg}{2x} \left(\frac{v^2}{gR} \cos \theta - \sin \theta \right) \\
 &= \frac{20000}{2} \left[\frac{11.1^2}{9.81 \times 30} * 0.1736 + 0.9848 \right] - \frac{1 \times 20000}{1} \left[\frac{11.1^2}{9.81 \times 40} * 0.9848 - 0.1736 \right]
 \end{aligned}$$

$$\begin{aligned}
 R_A &= 5751 \text{ N} \\
 R_B &= 15407 \text{ N}
 \end{aligned}$$

Let the force at each pair of wheels or each rail due to gyroscopic couple = Fg

∴ Gyroscopic couple applied = Iω cosθ ωp

$$\begin{aligned} \therefore F_g * 2x &= I\omega \cos\theta \omega_p \\ &= \frac{I\omega \cos\theta \omega_p}{2x} \end{aligned}$$

$$\text{But, } I = mk_g^2 = \frac{2000}{9.81} * 0.25^2 = 12.74 \text{ kg m}^2$$

$$\omega_p = \frac{V}{R} = \frac{11.1}{30} = 0.37 \text{ rad/s}$$

$$\omega = \frac{V}{r} = \frac{11.1}{\frac{30}{2}} = 37 \text{ rad/s}$$

$$F_g = \frac{12.74 * 37 * 0.9848 * 0.37}{1} = 172 \text{ N}$$

$$\begin{aligned} \therefore \text{Reaction on inner rail} &= R_A - F_g \\ \text{ii) } &5751 - 172 \\ &5479 \text{ N} \end{aligned}$$

$$\begin{aligned} \therefore \text{Reaction on outer rail} &= R_A + F_g \\ \text{1) } &15407 + 172 \\ &15579 \text{ N} \end{aligned}$$

REFERENCES

- 1.S.S.Rathan(2009),Theory of Machines,3rd edition, Tata MC Graw Hill Education Pvt.td, New Delhi.
- 2.SadhuSingh(2012),Theory of Machines,3rd edition,Pearson, New Delhi.
- 3.Ballaneys(1994),Theory of Machines,19th edition, Hanna Publications, Delhi.
- 4.Sharma,C.S, Kamalesh Purohit(2006),Theory of Mechanisms and Machines, Prentice-Hall of India Pvt. Ltd. New Delhi.
- 5.Malhotra and Guptha (2006),TheTheory of Machines,3rd edition Sathy Prakashan, New Delhi.
- 6.Ashok A.G(2009), Mechanisms and Machine Theory, 2nd edition, PHI Learning Pvt. Ltd. New Delhi.