

Module 4

MEASUREMENTS AND MEASUREMENT SYSTEMS

CONTENTS

4.1 Definition

4.2 Significance of measurement

4.3 Generalized measurement system,

4.4 Errors in measurement

4.5 Transducers

OBJECTIVES

After studying this unit, you should be able to

1. Describe different type of sensors and transducers, and
2. Understand the concepts of digital to analog conversion and vice-versa.

Definition of measurement:

Measurement is defined as the process of obtaining a quantitative comparison between a predefined standard & an unknown magnitude. Example-consider the measurement of length of bar. We make use of a scale/steel ruler(i.e a standard)

Definition of Standard

Standard is a value of some quantity which is setup and established by authority as a rule for measurement of a quantity.

The system of measurement must be related to a known standard or else the standard has no meaning.

- Any system may be represented by a simple block diagram.

- Simple diagrams of rectangles and circles connected by lines with indicators of input and output directions.
- Shows the essential elements of a system.
- Functional arrangements + functions of each element.

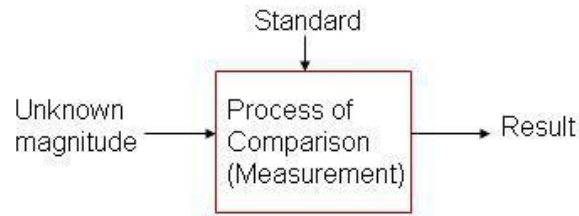

Length of the bar-unknown quantity (measure and) }
 Scale-pre-defined standard } Compare

i.e. compare the unknown length of the bar with a known length/pre-defined standard.
 We say that the bar measures so many mms, cms or inches in length. Definition-measurement is an act of quantitative comparison between an unknown magnitude and pre-defined standard.

Basic Requirements of Measuring System

Two main requirements must be met in the act of measurement. They are;

- The standard used for comparison must be accurately defined and commonly accepted.
- The procedure employed for the measurement & the apparatus used for comparison must be provable.

Significance of Measurements

1. We require measuring quantities for performance in our day to day activities.
2. Fundamental requirement of any process is the measurement. Example-



- 3 i.e. input is fed to the system it undergoes a process output is indicated.
- 4 i.e. output is compared with input-measurement.
5. Quantities pertaining to operation & performance of the device being developed.
6. Measurement provides the fundamental basis for research & development as it involves measurement of various quantities and parameters.
7. Also, a fundamental element of any control process, which requires the measured discrepancy between the actual & desired performances.
 - Measurement is also considered as a method of inspection
 - Measurement technology combined with computer integrated manufacturing and database management systems provide information based process control
 - I.e. to prevent the occurrence of more number of defects

- 8) To ensure proper performance in operations of modern power stations to monitor temperature, pressure, vibration amplitudes etc.
- 9) Establish the cost of products on the basis of amount of material, power, time & labor, etc.
- 10) Place/give realistic tolerance for each of the measured values.

To establish the validity of design

1. Design of manufactured goods
2. Design of machinery to perform manufacturing operations
3. Design of power sources
4. Design of roads, waterways and other system.
5. To study the operation features, limitation and difficulties that are inherent in the systems.
6. For proper maintenance of the equipment.
7. To determine the system response(Reply of the systems to given input)
8. For correct recording of the output data(weather forecasting, experimental values, interpretation etc.)

Other applications of measurements

1. Application of theory

- Broaden the engineering knowledge by application of theory.
- Learn to verify a theoretical model or to verify/modify it by conducting experiments.
- Develop ability to apply some basic principle in a variety of engineering studies- interdisciplinary approach.

2. Techniques of experimentation

- Become acquainted with available experimentation.
- Learn to interpret experimental data.
- Develop competence in sampling data.

3. Communication and reporting

- Learn to organize and direct experimental team.
- Learn procedures and develop abilities in report writing.
- Learn to support conclusions and recommend improvements.

4. Professional

- Provide examples of experimental research and development.
- Develop competence in applying engineering judgment.

Hence considering the above, it can be concluded that measurements are quite essential in the

- Design of a component.
- A process to be operated with minimum cost having maximum efficiency.

Fundamental methods of Measurement

Two basic methods are commonly employed for measurement.

- (a) Direct comparison with primary or secondary standard.
- (b) Indirect comparison through the use of calibrated system.

Two basic methods are commonly employed for measurement.

- (a) Direct comparison with primary or secondary standard.
- (b) Indirect comparison through the use of calibrated system.

Direct comparison

In this method, measurement is made directly by comparing the unknown magnitude with a standard & the result is expressed by a number. The simplest example for this would be, length measurement using a meter scale. Here we compare the bar's length(unknown quantity/measure and) with a scale (Standard/predefined one). We say that the bar measures so many mms, cms or inches in length.

- Direct comparison methods are quite common for measurement of physical quantities like length, mass, etc.
- It is easy and quick.

Drawbacks of Direct comparison methods

- The main drawback of this method is, the method is not always accurate and reliable.
- Also, human senses are not equipped to make direct comparison of all quantities with equal facility all the times.
- Also, measurement by direct methods are not always possible, feasible and practicable.

Example: Measurement of temperature, Measurement of weight.

- One can experience or feel the hotness or coldness of a body with respect to a particular environment.
- But may not be able to exactly predict or say the temperature.
- Further , these measurements in most cases involve human factors.
- Hence this method in general is not preferred and employed for very accurate measurements.

Indirect comparison

- Most of the measurement systems use indirect method of measurement.
- In this method a chain of devices which is together called as *measuring system* is employed.
- The chain of devices transform the sensed signal into a more convenient form & indicate this transformed signal either on an indicator or a recorder or fed to a controller.
- i.e. it makes use of a transducing device/element which convert the basic form of input into an analogous form, which it then processes and presents as a known function of input.
- For example, to measure strain in a machine member, a component senses the strain, another component transforms the sensed signal into an electrical quantity which is then processed suitably before being fed to a meter or recorder.
- Further, human senses are not equipped to detect quantities like pressure, force or strain.
- But can feel or sense and cannot predict the exact magnitude of such quantities.
- Hence, we require a system that detects/sense, converts and finally presents the output in the form of a displacement of a pointer over a scale a , a change in resistance or raise in liquid level with respect to a graduated stem.

DIRECT COMPARISON	INDIRECT COMPARISON
1)Unknown quantity is measured comparing directly with primary or secondary standards	1)unknown magnitude is measured by comparing with a standard indirectly through the use of a calibrated system
2)human senses are very much necessary for measurement	2)Consists of a chain of devices which form a measuring system
3)Results obtained from direct comparison are not that dependable	3)this consists of a detector element to detect ,a transducer to transducer and a unit to indicate or record the processed signal
4)Not always accurate	4)Fairly accurate .

Primary, secondary and tertiary measurements

- Measurements are generally made by indirect comparison method through calibration.
- They usually make use of one or more transducing device.
- Based upon the complexity of measurement system, three basic categories of measurements have been

developed. They are;

1. Primary measurement
2. Secondary measurement
3. Tertiary measurement

Primary measurement

- It is the one that can be very easily made by direct comparison method/direct observation.
- This can be done without any conversions or translation into lengths or displacements.
- Here, the sought value of the parameter is determined basically by comparing it directly with reference standards

Examples:

- Matching of two colors-in finding the temperature of a red hot object.
 - Use of a physical balance-in measuring weights
 - Matching or comparing lengths-to find out the length of the object
 - This measurement is quite easy, but takes more time.
 - Provides only subjective information.
- a. Example: An observer is in a position to tell that the contents of one container is heavier than the other or contents of one object is hot than other.
- Hence, this method is not always accurate and reliable. So, secondary measurements are resorted to.

Bellows

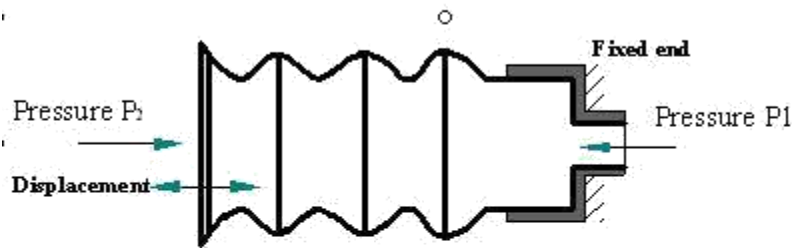

Metallic Bellow

- Metallic bellows are thin walled tubes formed by hydraulic presses into a corrugated shape as shown in fig. Bellows can be of diameters upto 300 mm & are made of Brass, (80% copper & 20% zinc), Phosphor bronze, stainless steel, Beryllium copper.
- A differential pressure causes displacement of the bellows, which may be converted into an electrical signal.
- When pressure P above the atmosphere is applied, to the free/open end of the bellows, these expand.
- The resulting displacement is a measure of applied pressure.
i.e. $x \propto p$ k =proportionality constant
or $x = k.p$ x =Displacement in mms
 p =applied pressure

Spiral Springs

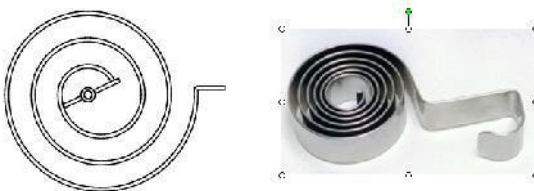

- These are used to produce controlling torque in analogue type electrical instruments and clocks.
- The controlling torque will be proportional to the angle of deflection.
- Care must be taken *not to stress* the springs beyond *the elastic limit* as it will lead to permanent deformation.

Force to displacement by springs:

The spring stretches when force F is applied at its free end $\delta \propto F$ or $\delta = k.F$

$$\delta = k.F/s$$

δ =spring deflection

k =proportionality constant

F =force applied

s =spring stiffness

Strain gage Load Cell

- Load cell consists of a short column on which electrical resistance strain gauges are mounted.
- When force F is applied it deflects or strains the block.
- Here, the load is converted to strain and this is transformed into change in electrical resistance.
- In this, the block forms the primary detector transducer, the gauges mounted on the block acts as secondary transducer.

Bourdon Tube

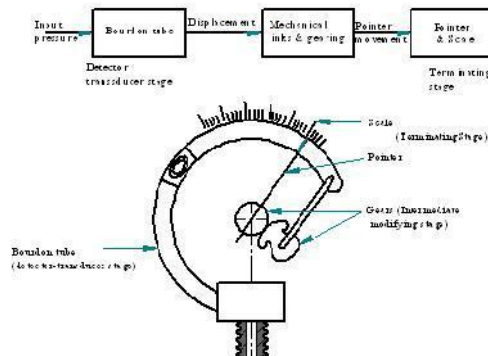

- When pressure p , the primary signal is applied to the open end of the Bourdon tube, the other end deflects.
- This deflection will be very small(constitutes the secondary signal) and needs to be made larger for display purpose.
- This is obtained by the arrangement of gear, rack and pinion arrangement and a pointer moving against a graduated scale(which constitutes the tertiary signal).

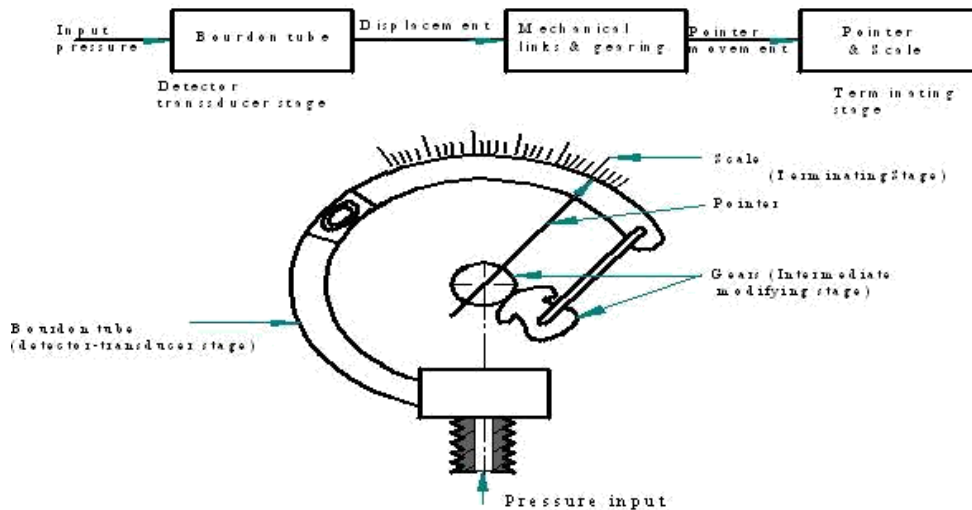

- When pressure p , the primary signal is applied to the open end of the Bourdon tube, the other end deflects.
- This deflection will be very small (constitutes the secondary signal) and needs to be made larger for display purpose.
- This is obtained by the arrangement of lever, rack and pinion arrangement and a pointer moving against a graduated scale (which constitutes the tertiary signal).

Tertiary Measurements

- These tertiary measurements involve two or more translations or conversions. Example: Bourdon pressure gauge for measurement of pressure

Generalized Measurement System

- It can be considered as a system that is used to measure the required quantity/parameter.

Generalized measurement system consists of the following elements:

1. Primary Sensing Element (detecting element) (detector-transducer element)
2. Variable Conversion Element-Intermediate modifying element.
3. Data Processing and Data Presentation element-Terminating stage element.

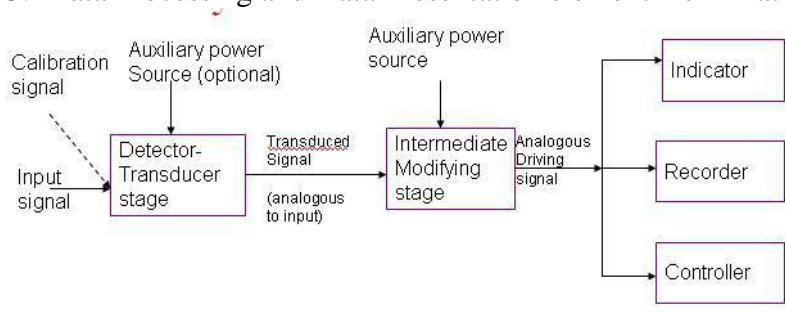

Most measuring systems fall within the frame work of a generalized system Consisting Of three stages namely

- (1) A *detector-transducer* or *sensor* stage
- (2) An *intermediate modifying* stage or *signal conditioning* stage
- (3) A *terminating* or *read-out* stage, as shown in the block diagram above.

Basic elements of a Measuring system:

Stage I-Detector Transducer Device	Stage II-Intermediate Modifying Device	Stage III-Terminating Device
Senses only the desired input & provides analogous output	Modifies Transduced signal into a form usable by final stage. Usually increases amplitude and power	Provides an indication or recording in a form that can be evaluated by human sense or by a controller

<i>Types & Examples</i>	<i>Types & Examples</i>	<i>Types & Examples</i>
Mechanical : Contacting spindle, Spring-mass, elastic devices such as bourdon tube, proving ring, etc. Hydraulic-Pneumatic: Buoyant-float, orifice, venturi, vane, propeller Optical: Photographic film, Photoelectric cell Electrical: Contactors, resistance, capacitance, Piezoelectric crystal, Thermocouple, etc.	Mechanical : Gearing, cranks, links, cams, etc. Hydraulic-Pneumatic: Piping, valves, dash-pots, etc Optical: Mirrors, lenses, Optical filters, light levers, Optical fibers. Electrical: Amplifying systems, matching devices, filters, telemetry systems, etc.	INDCATORS (a) Displacement types Moving pointer & scale, light beam & scale, CRO, liquid column, etc. (b) Digital types: Direct alphanumeric read out (c) Recorders: Digital printing, inked pen & chart Light beam & photographic Film, magnetic recording (d) Controllers: All types

Stage-I-Detector Transducer stage:

The important function of this stage is to detect or to sense the input signal. At the same time, it should be insensitive to every other possible input signals. For ex, if it is a pressure signal, it should be insensitive to acceleration. In the measurement of strain, the strain gauges should be insensitive to temperature.

- Automobile tyre gauge-used for measurement/checking air pressure of an automobile tyre.
- Construction: consists of a cylinder, a piston, a spring resisting the piston movement and a stem with graduation.
- As the air pressure bears against the piston, the resulting force compresses the spring until the spring force and air forces are balanced.

Stage-I-Detector Transducer stage

- Here, the piston and cylinder combination make up the detector transducer, spring other element.
- Other examples-refer fig

Other pressure sensing devices

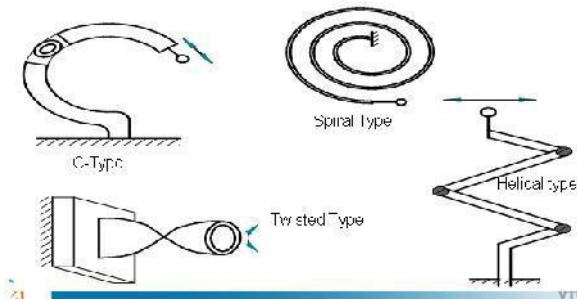

Stage-II-Intermediate modifying stage:

- As the name itself indicates, this lies between stage 1 and stage 3.
- The main function of this stage is to modify the detected/transduced information so that it is acceptable to the third, or terminating stage.
- The important function of this stage is to increase either amplitude or power of the signal or both, to the level required to drive the final terminating device.
- It may also perform selective filtering, integration, differentiation, etc. as required.
- Generally these will be electrical or electronics circuits.
- Examples: Amplifiers, mechanical levers

Stage III-Terminating stage

- This stage provides an indication or a recording of the signal in a form which can be understood by a human being or a control system.
- This is done by data presentation element.
- Here the information output may be obtained in different forms such as a pointer moving over a graduated scale, in digital form as in computers or as a trace on an oscilloscope etc.
- An example of a generalized measurement system is a simple Bourdon tube pressure gauge.
- In this case, the pressure is sensed by a tube of elliptical cross section which undergoes mechanical deformation. (c/s tends to become circular)
- The gearing arrangement amplifies the displacement at the end of the tube so that a relatively small displacement of the tube end produces a greater revolution of the center gear.
- The final indicator stage consists of a pointer and scale arrangement, which when calibrated with known pressure inputs, gives an indication of pressure signal acting on the bourdon tube.

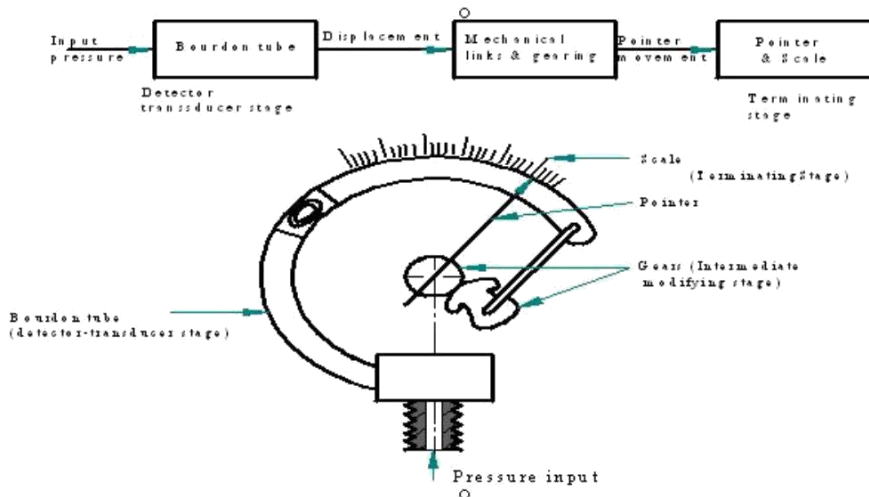

In 1849 the Bourdon tube pressure gauge was patented in France by Eugene Bourdon. It is still one of the most widely used instruments for measuring the pressure of liquids and gases of all kinds, including steam, water, and air up to pressures of 100,000 pounds per square inch. Eugene Bourdon founded the Bourdon Sedeme Company to manufacture his invention.

Instrument Characteristics(Behaviour)

- The instrument and measurement system characteristics can be divided into two distinct categories-
 1. Static characteristics
 2. Dynamic characteristics

Static characteristics

- Pertain to a system where quantities to be measured, are constant or vary very slowly with time.
- Normally static characteristics of a measurement system are those that must be considered when the system/equipment is used to measure a condition not varying with respect to time.

Dynamic characteristics

- Pertain to a system where quantities to be measured vary rapidly with time.

- There are many phenomenon which can be conveniently described by the static response while on the other hand there are phenomenon which can only be reported by dynamic response.
- The overall performance of a system, many a times can be evaluated by semi-qualitative super position of static and dynamic characteristics.

Definitions & basic concepts

Readability: This term indicates the closeness with which the scale of the instrument may be read. *For ex, an instrument with 30 cm scale has a higher readability than that of a 15 cm scale.* Least count: It is the smallest difference between two indications that can be detected on the instrument scale.

Range: It represents the highest possible value that can be measured by an instrument *or* it is the difference between the largest & the smallest results of measurement. Example-

Data : Elemental items of information obtained by experimental means - assumed to be in numerical forms. Example-

Population(also called universe): A collection of data, either from finite or infinite in number all representing the same quantity. Example-

Sample : A portion of a population, represent the time value or should be a representative of the population.

- Multi sample test: A repeated measurement of a given quantity using altered test conditions - such as different observers or different instrumentation.
- Merely taking repeated reading with the same procedure and equipments does not provide multi sample results.
- Example : Many experimenters have conducted experiments to determine the velocity of light in vacuum.
- This has been done using different apparatus and techniques. Each leading measured is supposedly a unique quantity. Although, the results vary, taken together, these finding are multi sample results.
- Single sample test : A single reading or succession of reading taken under identical conditions except for time.
-

True value or actual value (V_a): It is the actual magnitude of the input signal to a measuring system which may be approximated but never truly be determined. The true value may be defined as the average of an infinite number of measured values, when the average deviation of the various contributing factors tend to zero. *Indicated value (V_i):* The magnitude of the input signal indicated by a measuring instrument is known as indicated value. This is the supply of raw or directly recorded data. *Correction*: It is the revision applied to the indicated value which improves the worthiness of the result. Such revision may be in the form of either an additive factor or a multiplier or both. *Result (V_r)* : It is obtained by making all known corrections to the indicated value. $V_r = AV_i + B$, where A & B are multiplicative & additive corrections.

Discrepancy : The difference between two indicated values or results determined from a supposedly fixed time value.

Error: It is the difference between the true value (V_a) & the result (V_r). $Error = (V_r - V_a)$

Accuracy: The accuracy of an instrument indicates the deviation of the reading from a known input. In other words, accuracy is the closeness with which the readings of an instrument approaches the true values of the quantity measured. It is the maximum amount by which the result differs from the true value.

$$\text{Accuracy} = \text{Maximum error} = V_r(\text{max}) - V_a$$

Accuracy is expressed as a percentage based on the actual scale reading / full scale reading. Percentage accuracy based on reading =

$$\frac{(V_r(\text{max or min}) - V_a)}{V_a} * 100$$

$$\text{Percentage accuracy based on full scale reading} = \frac{(V_r(\text{max or min}) - V_a)}{V_{fs}} * 100$$

V_{fs} = maximum reading the measuring system capable for the particular setting or scale being used. Also accuracy is based on the limits of application. The cost of the system increases rapidly if increased rapidly if increase accuracy is decreased. The limits should be made as wide as possible. Further, a system cannot be accurate 100% at all times because an error is required to initiate the corrective action.

Ex : pressure 100 bar +/- 1 bar i.e. 100 bar pressure gauge having an accuracy of 1% would be accurate within +/- 1 bar over the entire range of gauge.

Precision: The precision of an instrument indicates its ability to reproduce a certain reading with a given accuracy. In other words, it is the degree of agreement between repeated results. Precision data have small dispersion (spread or scatter) but may be far from the true value. A measurement can be accurate but not precise, precise but not accurate, neither, or both. A measurement system is called *valid* if it is both accurate and precise.

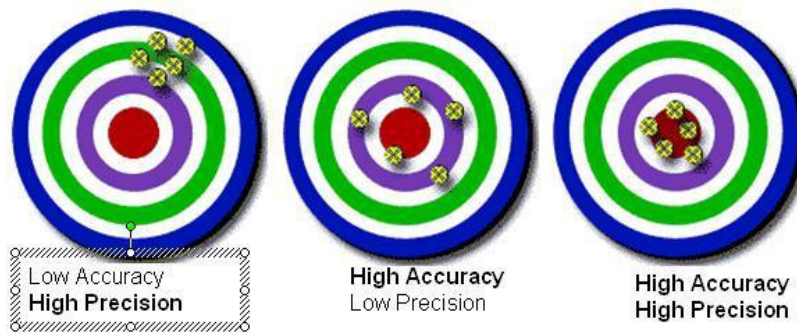

Sl no	Accuracy	Precision
1	It is the closeness with the true value of the quantity being measured	It is a measure of reproducibility of the measurements
2	The accuracy of measurement means conformity to truth	The term precise means clearly or sharply defined
3	Accuracy can be improved	Precision cannot be improved
4	Accuracy depends upon simple techniques of analysis	Precision depends upon many factors and requires many sophisticated techniques of

		analysis
5	Accuracy is necessary but not sufficient condition for precision	Precision is necessary but not a sufficient condition for accuracy

Calibration: *It is very widely used in industries. It is the setting or correcting of a measuring device or a base level usually by adjusting it to match or conform to a dependably known value or act of checking or adjusting (by comparing with standard) the accuracy of a measuring instrument.*

It is the procedure employed for making adjustments or checking a scale for the readings of a system conforming to the accepted or pre defined standard i.e. to say that the system has to prove its ability to measure reliably. Every measuring system must be provable. The procedure adopted to prove the ability of a measuring system to measure reliably is called calibration.

In this process, known values of input are fed to the system and the corresponding output is measured. A graph relating the output with input is plotted which is known as ‘calibration curve’

- During the process of experimentation known values of input magnitude are fed and the corresponding output is measured.
- A plot of output against the input is drawn and is called the calibration graph.

Threshold: If the instrument input is increased very gradually from zero, there will be some minimum value of input below which no output change can be detected. This minimum value defines the threshold of the instrument.

Hysteresis: An instrument is said to exhibit hysteresis when there is a difference in readings depending on whether the value of the measured quantity is approached from higher value or from a lower value as shown in

- Hysteresis arises because of mechanical friction, magnetic effects, elastic deformation or thermal effects.
- Hysteresis is a phenomenon which depicts different output effects when loading and unloading.
- It may be with respect to a mechanical system, electrical system or any system.
- Hysteresis is the non coincidence of loading and unloading curves.
- Consider an instrument which has no friction due to sliding or mating parts.
- When the input of this instrument is slowly varied from zero to full scale and then back to zero, its output varies as shown
- Hysteresis in a system arises due to the fact that all the energy put into the stress parts when loading is not recoverable upon unloading.

Typical Hysteresis curve

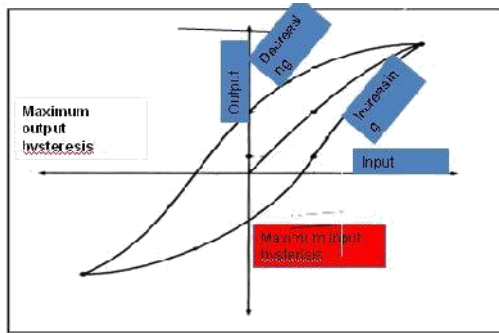

Sensitivity: It is the ratio of the linear movement of the pointer on the instrument to the change in the measured variable causing this motion or is the ratio of the magnitude of output quantity(response) to the magnitude of the input quantity.

For ex, a 1 mV recorder might have a 10 cm scale. Its sensitivity would be 10 cm/mV, assuming that the measurement is linear all across the scale.

- The static sensitivity of an instrument can be defined as the slope of the calibration curve. The sensitivity of an instrument should be high and the instrument should not have a range greatly exceeding the value to be measured. However some margin should be kept for accidental overloads.
- Sensitivity of an instrument is the ratio of magnitude of the response (output signal) to the magnitude of the quantity being measured (input signal).
- Sensitivity (k)= $\frac{\text{change of output signal}}{\text{change of input signal}}$
- Sensitivity is represented by the slope of the calibration curve.
- Sensitivity of the instrument system is usually required to be as high as possible as it becomes easier to take the measurement.

Resolution or Discrimination: It is defined as the smallest increment of input signal that a measuring system is capable of displaying. Resolution is defines the smallest measurable input change while threshold defines the smallest measurable input. Threshold is measured when the input is varied from zero while the resolution is measured when the input is varied from any arbitrary non- zero value.

Repeatability: It is defined as the ability of a measuring system to reproduce output readings when the same input is applied to it consecutively, under the same conditions, and in the same direction.

Reproducibility: It is defined as the degree of closeness with which the same value of a variable may be measured at different times.

Linearity: A measuring system is said to be linear if the output is linearly proportional to the input. A linear system can be easily calibrated while calibration of a non linear system is tedious, cumbersome & time consuming. Most of the systems require a linear behavior as it is desirable . I.e. output is linearly proportional to input.

- This is because the conversion from a scale reading to the corresponding measured value of input quantity is most convenient as one has to merely multiply by a fixed constant rather than a non linear calibration curve or compute from non linear curves and equation.
- Also it is to be noted that all non linear calibration curves are not inaccurate. Sometimes they may be more accurate than linear calibration curves.

Hence , many definition of linearity exists.

The best fitting straight line or method of least squares may be used to plot input vs. output data

Loading effect: The presence of a measuring instrument in a medium to be measured will always lead to extraction of some energy from the medium, thus making perfect measurements theoretically impossible.

This effect is known as ‘loading effect’ which must be kept as small as possible for better measurements. For ex, in electrical measuring systems, the detector stage receives energy from the signal source, while the intermediate modifying devices and output indicators receive energy from auxiliary source. The loading effects are due to impedances of various elements connected in a system

System response: Response of a system may be defined as the ability of the system to transmit & present all the relevant information contained in the input signal & to exclude all others. If the output is faithful to input, i.e. the output signals have the same phase relationships as that of the input signal, the system is said to have good *System response*. If there is a lag or delay in the output signal which may be due to natural inertia of the system, it is known as ‘*measurement lag*’ “Rise time” is defined as the time taken for system to change from 5% to 95% of its final value. It is a measure of the speed of response of a measuring system and a short rise time is desirable.

Amplitude Response

- A system is said to have to good amplitude response if it treats all the input amplitudes uniformly. i.e. if an input amplitude of 5 units is indicated as 20 units on the output side, an input of 10 units should give 40 units on the output side.
- In practice a measuring system will have good amplitude response over an unlimited range of input amplitudes.
- For ex, a 3-stage amplifier used for strain measurement has good response upto an input voltage of 10⁻² volts as shown in fig.

Amplitude response of 3-stage amplifier used for strain measurement

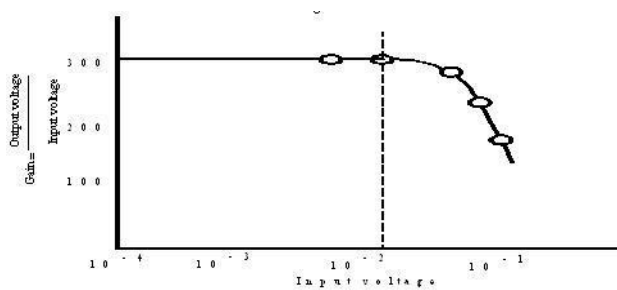

Frequency response

A system is said to have a good frequency response when it treats all input frequencies with equal faithfulness. For ex, if an input amplitude of 5 units at 60 Cps is indicated as 10 units on the output side, then irrespective of the change in input frequency, the output amplitude should not change as long as the input amplitude does not change. In practice a measuring system will have a lower & upper limits beyond which the system can not have a good frequency response.

The fig shows response curve of a device which has good frequency response between 5 Cps & 30,000 Cps.

Frequency response of 3-stage amplifier used for strain measurement

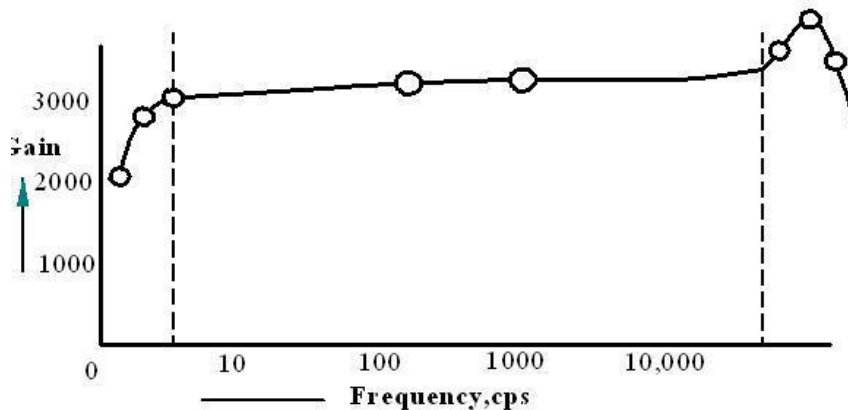

Phase response

- Amplitude response and frequency response are important for all types of input signals whether simple or complex. The phase response is, however, important only for complex waves.
- If the input signal is simple like a sine wave, the amplitude of the output, though out of phase with input, will not be affected. This is because the shape of the cycle is repetitive and does not change between the limits of the cycle.
- If the input signal is simple like a sine wave, the amplitude of the output, though out of phase with input, will not be affected. This is because the shape of the cycle is repetitive and does not change between the limits of the cycle.

Effect of poor phase response on recording of strain

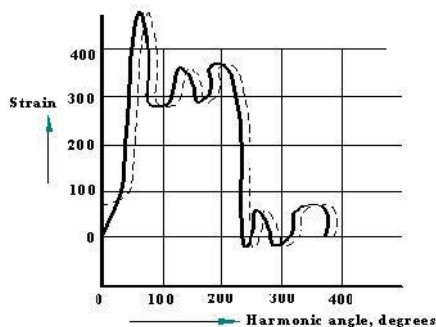

Errors in Measurements

Error may be defined as the difference between the measured value and the true value.

No measurement can be made without errors at all times i.e. 100% accurate measurements cannot be made at all times.

Error definition:

- Is defined as the difference between the best measured value and the true value of the quantity.
- A mistake, or inaccuracy in action, speech or a typing error.
- A incorrect belief or a wrong judgment.
- Deviation from a standard.
- Measure of the difference between some quantity and an approximation to or estimate of it.
- Often expressed as a percentage.
- Difference between the true value of a measurement and the value obtained during the measurement process.

Error classification:

Classified in different ways

- Systematic error
- Random errors
- Illegitimate errors

Systematic errors:

- Generally they will be constant / similar form /recur consistently every time measurement is measured.
- May result from improper condition or procedures employed.

Calibration errors:

Calibration procedure-is employed in a number of instruments-act of checking or adjusting the accuracy of a measuring instrument.

Human errors:

- The term “human error” is often used very loosely.
- We assume that when we use it, everyone will understand what it means.
- But that understanding may not be same as what the person meant in using the term.
- For this reason, without a universally accepted definition, use of such terms is subject to misinterpretation.

Meanings- related to human error:

- Human error as a cause: Ex- a patient's adverse reaction-allergic to some medicine-administered by nurse.
- Human error as an event or action: A doctor forgets to match the patient record to patient identified.

- Human error as a consequence: A nurse leaves some sponge material inside a patient after surgery.

In all the above, the focus is on the outcome, yet description is of the action. Hence, we must use the human error term and relate to the event/measurement. Human errors may also be systematic as in case of an individual's tendency to consistently read high or low values when synchronized readings are to be taken. The apparatus and equipment itself may cause or lead to built-in errors resulting from incorrect design, fabrication, poor maintenance (Ex-defective gears, linkage mechanism etc.)

(1) Systematic or fixed errors:

- (a) calibration errors
 - (b) Certain types of consistently recurring human errors
 - (c) Errors of technique
 - (d) Uncorrected loading errors
 - (e) Limits of system resolution
- Systematic errors are repetitive & of fixed value. They have a definite magnitude & direction

(2) Random or Accidental errors:

- (a) Errors stemming from environmental variations
- (b) Certain types of human errors
- (c) Due to Variations in definition
- (d) Due to Insufficient sensitivity of measuring system

Random errors are distinguishable by their lack of consistency. An observer may not be consistent in taking readings. Also the process involved may include certain poorly controlled variables causing changing conditions. The variations in temperature, vibrations of external medium, etc. cause errors in the instrument. Errors of this type are normally of limited duration & are inherent to specific environment.

(3) Illegitimate errors:

- (a) Blunders or Mistakes
- (b) Computational errors
- (c) Chaotic errors

Illegitimate errors : should not exist and may be eliminated by careful exercise & repetition of measurement. Chaotic errors which may be due to extreme vibration, mechanical shock of the equipment, pick up of extraneous noise make the testing meaningless unless all these disturbances are eliminated. If a measuring instrument is not *calibrated* periodically it will lead to errors in measurement .

Human errors : are due to variation of physical & mental states of a person which may lead to systematic or random errors.

Errors of technique: are due to improper usage of measuring apparatus. This may include errors resulting from incorrect design, fabrication or maintenance.

Loading errors : result from influence exerted by the act of measurement on the physical system being tested.

Sources of errors

- (1) *Noise*: It is defined as any signal that does not convey useful information.
- (2) *Design limitations*: These are certain inevitable factors such as friction & resolving power which lead to uncertainty in measurements.
- (3) *Response time*: It is the time lag between the application of input signal & output measurement.
- (4) *Deterioration of measuring system*: Physical and/or chemical deterioration or other alterations in characteristics of measuring system constitute a source of error in measurement.
- (5) *Environmental effects*: The change in atmospheric temperature may alter the elastic constant of a spring, the dimensions of a linkage, electrical resistance etc. similarly other factors such as humidity, pressure etc. also affect measurements.
- (6) *Errors in observation & Interpretation*: It is the mistake of operators in observing, interpreting & recording the data.
- (7) Poor maintenance of the system

Introduction to Transducers

Transducer is a first stage element of the measurement system. It detects and transforms the sensed signal into a more useful form.

Transfer efficiency: It is the ratio of output information delivered by the pick up (Sensor) to the information received by the pick up.

Transfer efficiency $\frac{I_{out}}{I_{in}}$

Where I_{out} =the information delivered by the unit, I_{in} =information received by the unit

Since the pick up can not generate any information , the transfer efficiency can not be greater than unity. The detector- transducer stage must be designed to have a high Transfer efficiency to the extent possible.

Active & Passive Transducers: Active transducers

Also known as self generating type transducers Develop their own voltage or current. Energy required for production of output signal is obtained by quantity being measured.Ex, Electronic & Piezo electric transducers.

Passive Transducers:

- Also known as externally powered transducer
- Derive the power for energy conversion from an external power source
- Ex: Bonded electrical resistance strain gauges

Detector Transducer or Primary Transducer

Here the sensing element may serve to transduce the sensed input and convert into a more convenient form.

For example

1. Ordinary dial indicator-Spindle acts as a detector.
2. Load cell detects the force/load applied and gives an output in the form of a deflection.

Secondary Transducer

- Example-Strain gauge load cell-It detects the force and gives an output in the form of deflection. This deflection may further be converted into an electrical output by strain gauges(whose resistance value changes) mounted on the load cell.

Bourdon Pressure gauge

- The tube acts as detecting-transducing element-primary detector transducer.
- Linkage acts as a secondary transducer.

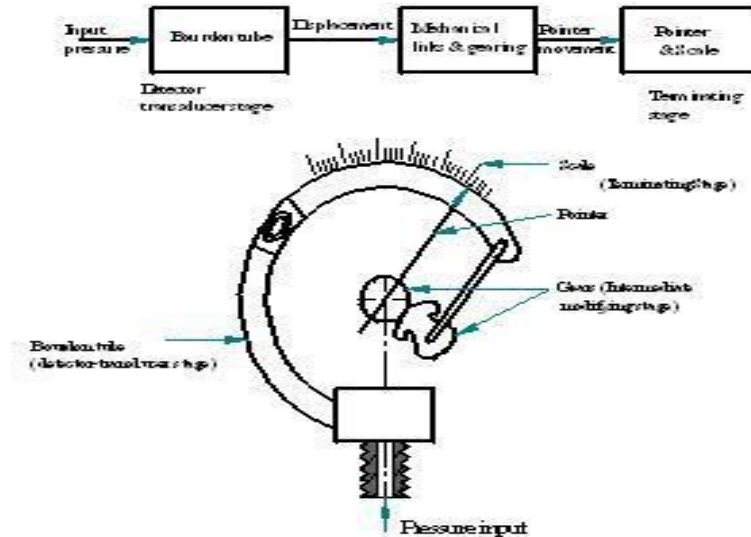

Primary Detector Transducer-Classification

Based on the number of operations performed:

- Class I-First stage element used as detector only.
- Class II-First stage element used as detector as well as transducer.
- Class III-First stage element used as detector and two transducer.

Mechanical Transducers

- Mechanical quantities include force, pressure, displacement, flow, temperature, etc.

- The mechanical transducers commonly used to convert the applied force into displacement are elastic members.
- They may be subjected to either direct tension/compression, Bending or Torsion.

Spiral springs: These are used to produce controlling torque in analogue type electrical instruments and clocks.

- The controlling torque will be proportional to the angle of deflection.
- Care must be taken *not to stress* the springs beyond *the elastic limit* as it will lead to permanent deformation.

Torsion bars: These are used in torque meters to sense torque which causes a proportionate angular twist which in turn is used as a measure of applied torque. (with the help of a displacement transducer)

Some torque meters, the strain gauges are used to sense the angular deformation.

- **Proving rings:** They are used to measure weight, force or load. The deflection can be measured with the help of micrometers, dial gauges or electrical transducers.

Pressure sensitive elements

Most pressure measuring devices use elastic members to sense the pressure. These elastic members convert pressure into displacement & can be of the following types;

- (i) Bourdon tubes
- (ii) Diaphragms
- (iii) Bellows

BOURDON TUBES

Bourdon tubes are elliptical cross section tubes bent into shapes as shown in fig.

- One end of the tube is sealed and physically held while the other end is open for the fluid to enter.
- The fluid whose pressure is to be measured enters the tube and tends to straighten the tube.
- This causes the movement of the free end which can be measured.
- The commonly used materials for bourdon tubes are brass, Phosphor bronze, Beryllium copper, etc.

Diaphragms

Diaphragms: Elastic diaphragms are used as primary pressure transducers in many dynamic pressure measuring devices.

- These may be either 'flat' or 'corrugated' as shown in fig.
- A diaphragm is a thin flat plate of circular shape fixed around its circumference.
- When a differential pressure ($P_1 - P_2$) occurs across the diaphragm, it will deflect as shown in fig.
- The deflection may be sensed by an appropriate displacement transducer such as strain gauge.
- A *flat diaphragm* is often used in conjunction with electrical secondary transducers whose sensitivity permits small diaphragm deflections.

- A *corrugated diaphragm* is useful when large deflections are required.
- An alternative form of diaphragm to obtain large deflections is a *metallic capsule* or pressure capsule, in which two corrugated diaphragms are joined back to back at their edges as shown in fig. Pressure P_2 is applied to the inside of the capsule which is surrounded by the pressure P_1

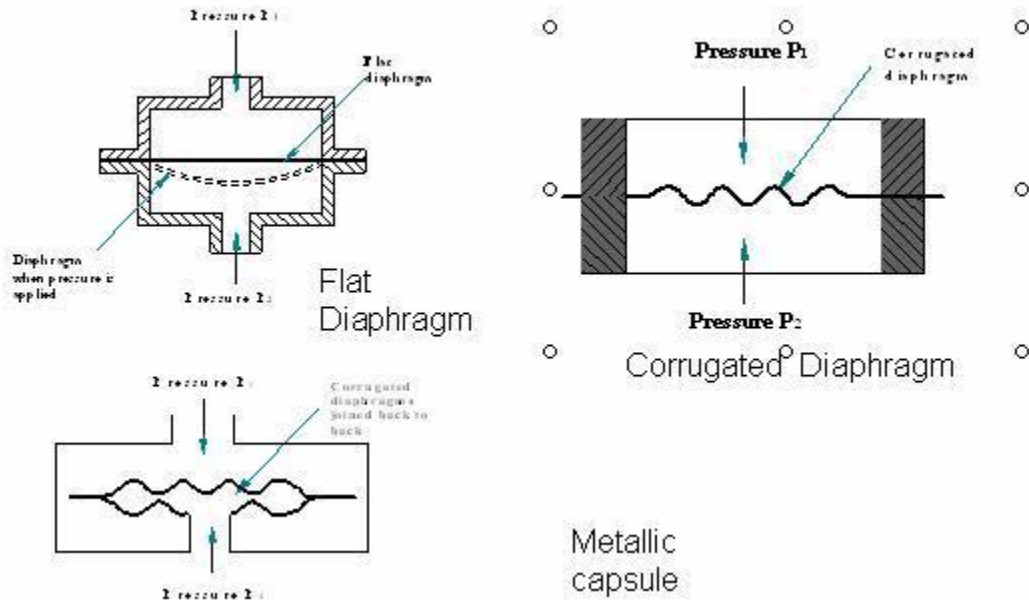

Bellow

Metallic bellows are thin walled tubes formed by hydraulic presses into a corrugated shape as shown in fig. Bellows can be of diameters upto 300 mm & are made of Brass, (80% copper & 20% zinc), Phosphor bronze, stainless steel, Beryllium copper. A differential pressure causes displacement of the bellows, which may be converted into an electrical signal.

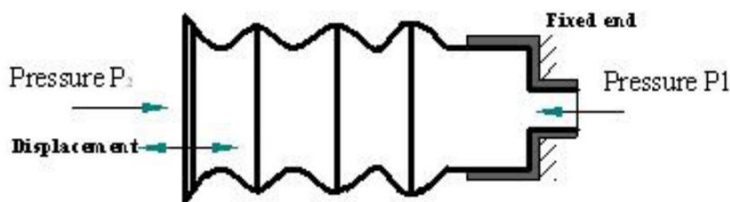

Metallic Bellow

Electrical transducer elements

- Most measuring devices have electrical elements as secondary transducers that convert the displacement of a primary sensor into electrical current, resistance or voltage.
- The transducers may be of resistive, inductive or capacitive type

Advantages of electrical transducers:

- (1) Very small size & compact.
- (2) Frictional & inertial effects are reduced .
- (3) Remote recording & control possible.
- (4) Amplification & attenuation of signals may be easily obtained.
- (5) Less power consumption.
- (6) Signal output may be easily processed and transmitted.

Resistive Transducers

The resistance of an electrical conductor varies according to the relation,

$$R = \frac{\rho L}{A}$$

where R= resistance in ohms, ρ = Resistivity of the material in ohm-cm, L= length of the conductor in cm, A= cross sectional area in cm². Any method of varying one of the quantities involved may be the design criterion for the transducer. Following are some types:

Sliding contact devices:

Convert mechanical displacement input into either current or voltage output - Achieved by changing the effective length of the conductor - The slide or contactor maintains electrical contact with the element and the slide is a measure of the linear displacement of the slide - Such devices are used for sensing relatively large displacements.

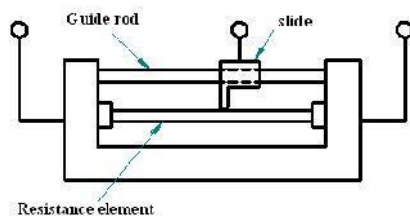

**Sliding contact
Resistive Transducer**

Potentiometers:

The resistance elements may be formed by wrapping a resistance wire around a card as shown in fig. In this the effective resistance between either end of the resistance element and the slide is a measure of angular displacement of the slide.

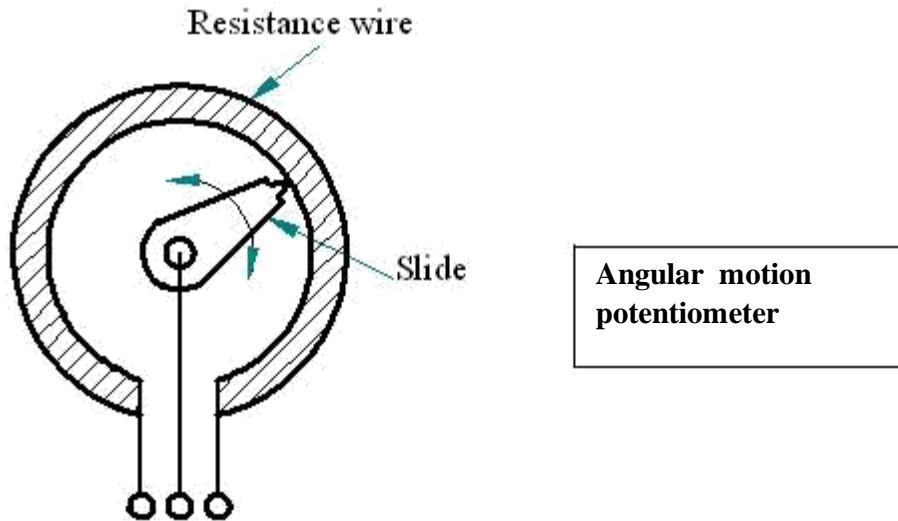

Angular motion potentiometer

- **Inductance** is the property in an electrical circuit where a change in the current flowing through that circuit induces an electromotive force (EMF) that opposes the change in current.
- In electrical circuits, any electric current i produces a magnetic field and hence generates a total magnetic flux Φ acting on the circuit.
- This magnetic flux, according to *Lenz's law* tends to oppose changes in the flux by generating a voltage (*a counter emf*) that tends to oppose the rate of change in the current.
- The ratio of the magnetic flux to the current is called the *self-inductance* which is usually simply referred to as the *inductance* of the circuit

Mutual Inductance:

When the varying flux field from one coil or circuit element induces an emf in a neighboring coil or circuit element, the effect is called Mutual Inductance.

Magnetic reluctance

Magnetic reluctance or magnetic resistance, is analogous to resistance in an electrical circuit.

In likeness to the way an electric field causes an electric current to follow the path of least resistance, a magnetic field causes magnetic flux to follow the path of least magnetic reluctance. Permeance is the reciprocal of reluctance

VARIABLE SELF INDUCTANCE TRASDUCER (Single Coil)

When a single coil is used as a transducer element, the mechanical input changes the permeance of the flux path generated by the coil, thereby changing its inductance.

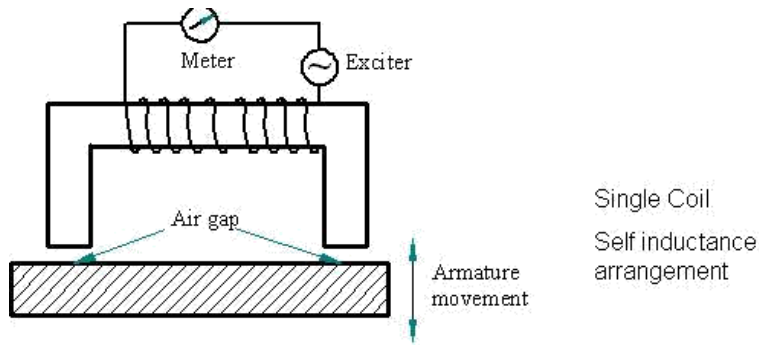

This change can be measured by a suitable circuit, indicating the value of the input. As shown in fig, the flux path may be changed by a change in the air gap.

The Two Coil arrangement, shown in fig, is a single coil with a center tap. Movement of the core alters the relative inductance of the two coils. These transducers are incorporated in inductive bridge circuit in which variation in inductance ratio between the two coils provides the output. This is used as a secondary transducer for pressure measurement.

Variable self inductance -Two Coil (Single coil with center tap)

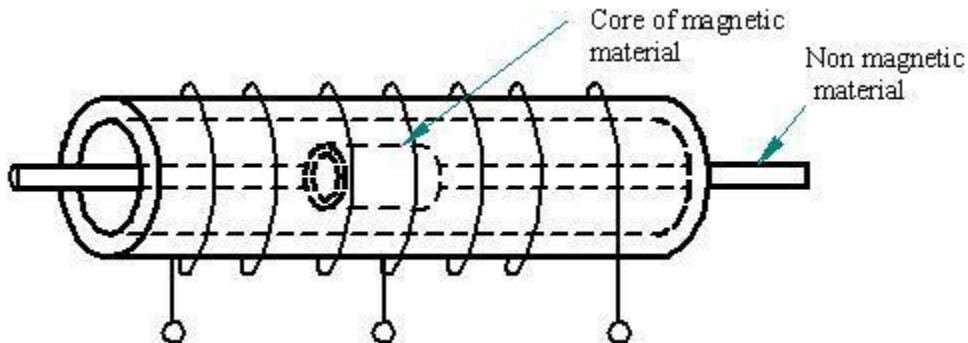

Variable Mutual inductance -Two Coil

- In this type, the flux from a power coil is coupled to a pickup coil, which supplies the output.
- Input information in the form of armature displacement, changes the coupling between the coils.
- The air gap between the core and the armature govern the degree of coupling.

Two Coil Mutual Inductance Transducer

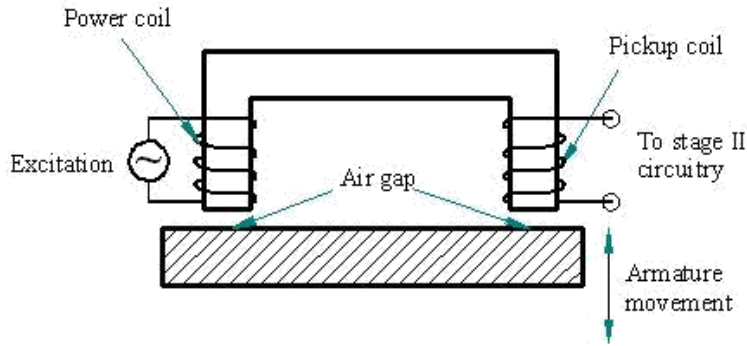

Note: Three Coil mutual inductance device (LVDT) is already discussed in Comparators Chapter.

A Variable reluctance Transducers are used for dynamic applications, where the flux lines supplied by a permanent magnet are cut by the turns of the coil. Some means of providing relative motion is included into the device.

- The fig shows a simple type of reluctance pickup consisting of a coil wound on a permanent magnetic core.
- Any variation of the permeance of the magnetic circuit causes a change in the flux, which is brought about by a serrated surface subjected to movement.
- As the flux field expands or collapses, a voltage is induced in the coil.

Variable Reluctance Transducer

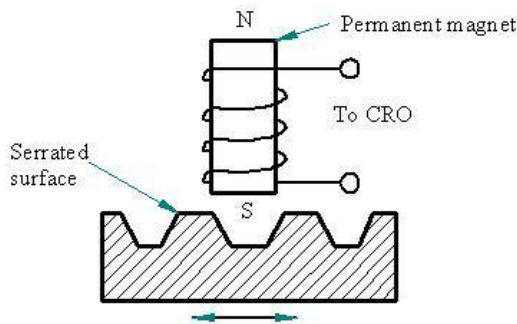

Capacitance Transducer

Generally it consists of two plates separated by a dielectric medium

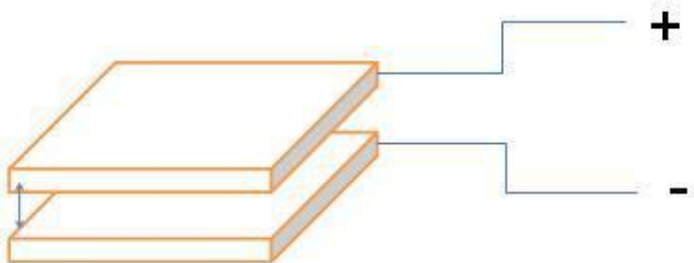

The principle of these type is that variations in capacitance are used to produce measurement of many physical phenomenon such as dynamic pressure, displacement, force, humidity, etc.

An equation for capacitance is $C = \frac{0.244KA(N-1)}{d}$ Farads

Where K = dielectric constant (for air $K=1$), A = area of one side of one plate, N = Number of plates, d = Separation of plate surfaces (cm)

The change in the capacitance may be brought about by three methods:

1. Changing the dielectric
2. Changing the area
3. Changing the distance between the plates
4. Fig shows a device used for the measurement of liquid level in a container.
5. The capacitance between the central electrode and the surrounding hollow tube varies with changing dielectric constant brought about by changing liquid level.
6. Thus the capacitance between the electrodes is a direct indication of the liquid level.
7. Variation in dielectric constant can also be utilized for measurements of thickness, density, etc.

Capacitance Pickup to measure liquid level (Changing dielectric constant)

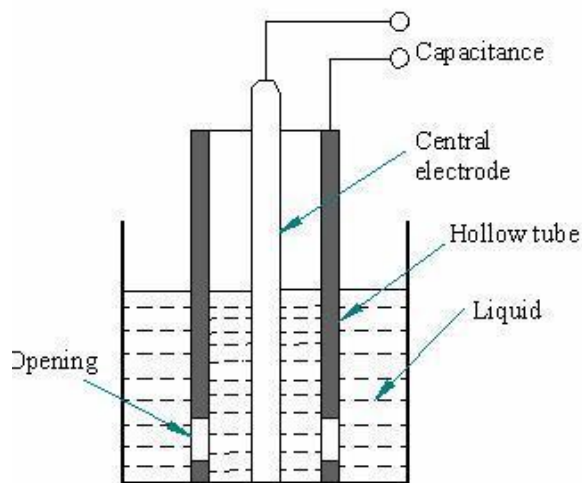

*****capacitance** is the ability of a body to hold an electrical charge.

Capacitance is also a measure of the amount of electric charge stored for a given electric potential. A common form of charge storage device is a two-plate capacitor. If the charges on the plates are $+Q$ and $-Q$, and V gives the voltage between the plates, then the capacitance is given by $C=(Q/V)$

The SI unit of capacitance is the farad; 1 farad = 1 coulomb per volt

Capacitive Transducer- Changing area:

- Capacitance changes depending on the change in effective area.
- This principle is used in the secondary transducing element of a *Torque meter*.
- This device uses a sleeve with serrations cut axially and a matching internal member with similar serrations as shown in fig.

- Torque carried by an elastic member causes a shift in the relative positions of the serrations, thereby changing the effective area. The resulting capacitance change may be calibrated to read the torque directly.

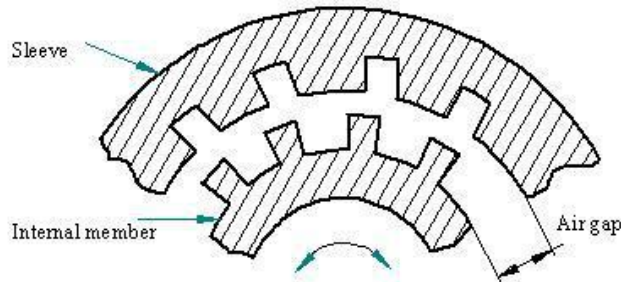

Torque Meter
(Capacitive type)

Capacitive Transducer-Changing distance

The capacitance varies inversely as the distance between the plates. The fig shows a capacitive type pressure transducer where the pressure applied to the diaphragms changes the distance between the diaphragm & the fixed electrode which can be taken as a measure of pressure.

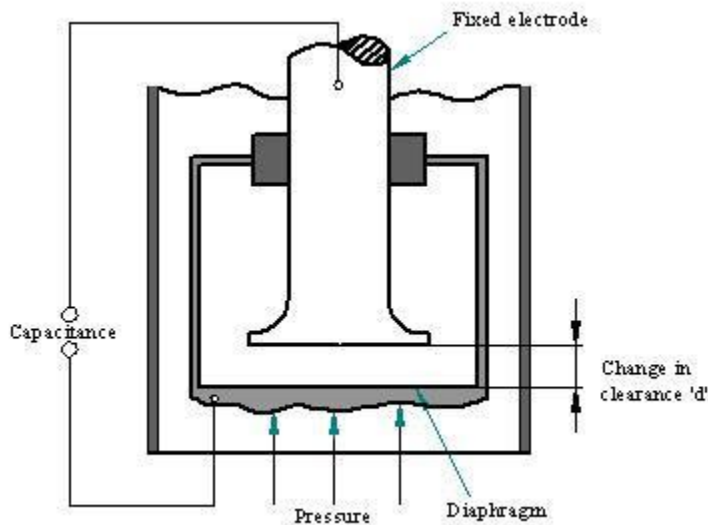

Capacitive type pressure pickup

Advantages of Capacitive Transducers

- (1) Requires extremely small forces to operate and are highly sensitive
- (2) They have good frequency response and hence useful for dynamic measurements.
- (3) High resolution can be obtained.
- (4) They have high input impedance & hence loading effects are minimum.
- (5) These transducers can be used for applications where stray magnetic fields render the inductive transducers useless.

Disadvantages of Capacitive Transducers

- (1) Metallic parts must be properly insulated and the frames must be earthed.
- (2) They show nonlinear behaviour due to edge effects and guard rings must be used to eliminate this effect.
- (3) They are sensitive to temperature affecting their performance.
- (4) The instrumentation circuitry used with these transducers are complex.
- (5) Capacitance of these transducers may change with presence of dust particles & moisture.

Piezoelectric Transducers :

- Certain materials can produce an electrical potential when subjected to mechanical strain or conversely, can change dimensions when subjected to voltage. This effect is called '*Piezoelectric effect*'.
- The fig shows a piezoelectric crystal placed between two plate electrodes and when a force 'F' is applied to the plates, a stress will be produced in the crystal and a corresponding deformation. The induced charge $Q=d \cdot F$ where 'd' is the piezoelectric constant
- The output voltage $E=g \cdot t \cdot p$ where 't' is crystal thickness, 'p' is the impressed pressure & 'g' is called voltage sensitivity given by $g=(d/e)$, e being the strain.

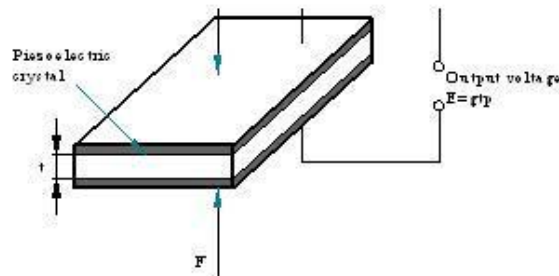

Piezoelectric effect

Piezoelectric materials

The common piezoelectric materials are quartz, Rochelle salt (Potassium sodium tartarate), ammonium dihydrogen phosphate and ordinary sugar. The desirable properties are stability, high output, insensitivity to temperature and humidity and ability to be formed into desired shape. Quartz is most suitable and is used in electronic oscillators. Its output is low but stable. Rochelle salt provides highest output, but requires protection from moisture in air & cannot be used above 45°C. Barium titanate is polycrystalline, thus it can be formed into a variety of sizes & shapes.

Piezoelectric transducers are used to measure surface roughness, strain, force & torque, Pressure, motion & noise. Desirable Properties of Piezoelectric Crystals Good stability, should be insensitive to temperature extremes, possess the ability to be formed to any desired shape.

Photoelectric Transducers:

A photoelectric transducer converts a light beam into a usable electric signal. As shown in the fig, light strikes the photo emissive cathode and releases electrons, which are attracted towards the anode, thereby producing an electric current in the circuit. The cathode & the anode are enclosed in a glass or quartz envelope, which is either evacuated or filled with an inert gas. The photo electric sensitivity is given by; $I = s \cdot f$ where I = Photoelectric current, s = sensitivity, f = illumination of the cathode. The response of the photoelectric tube to different wavelengths is influenced by

- (i) The transmission characteristics of the glass tube envelope and
- (ii) Photo emissive characteristics of the cathode material.

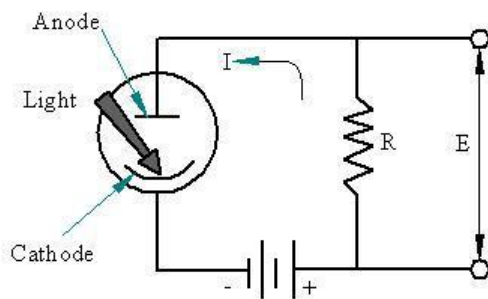

Photoelectric tubes are useful for counting purposes through periodic interruption of a light source

Photoconductive Transducers:

The principle of these transducers is when light strikes a semiconductor material, its resistance decreases, thereby producing an increase in the current. The fig shows a cadmium sulphide semiconductor material to which a voltage is applied and when light strikes, an increase in current is indicated by the meter.

Photoconductive transducers are used to measure radiation at all wavelengths. But extreme experimental difficulties are encountered when operating with long wavelength radiations.

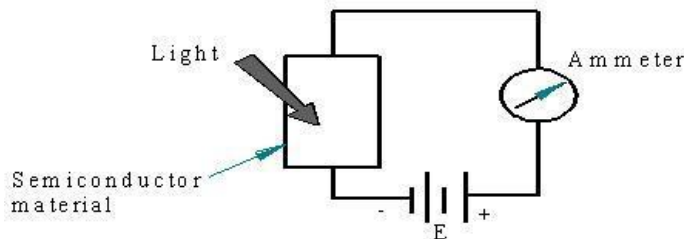

Photoconductive Transducer

The principle of *photovoltaic cell* is illustrated in the fig. It consists of a base metal plate, a semiconductor material, and a thin transparent metal layer. When light strikes the transparent metal layer and the semiconductor material, a voltage is generated. This voltage depends on the load resistance R . The open circuit voltage is a logarithmic function, but linear behavior may be obtained by decreasing the load resistance.

- It is used in light exposure meter for photographic work.
-

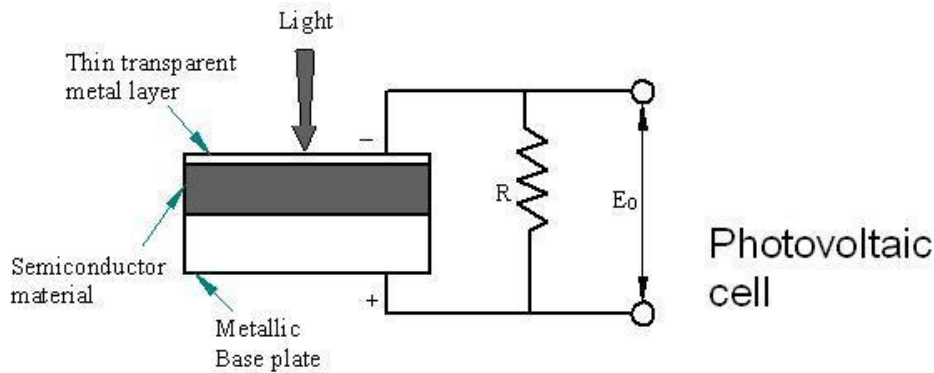

Ionization Transducers

- Ionization Transducers consist of a glass or quartz envelope with two electrodes A & B and filled with a gas or mixture of gases at low pressures.
- The radio frequency (RF) generator impresses a field to ionize the gas inside the tube.
- As a result of the RF field, a glow discharge is created in the gas, and the two electrodes A & B detect a potential difference in the gas plasma.
- It depends on the electrode spacing and the capacitive coupling between the RF plates and the gas
- When the tube is at the central position between the RF plates, the potentials on the electrodes will be the same, but when the tube is displaced from its central position, a D.C potential will be created.
- Thus ionization transducer is an useful device for measuring displacement.

Applications:

Pressure, acceleration & humidity measurements. They can sense capacitance changes of 10-15 farads or movements of 2.5×10^{-5} mm can be accurately measured with a linearity better than 1%.

Ionization Transducer

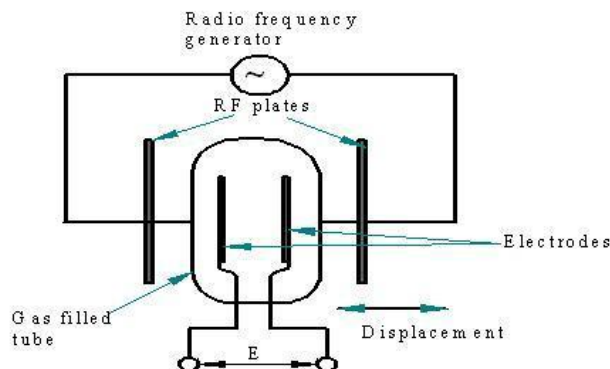

- The fig shows the schematic diagram of an *Electronic transducer* element which is basically an electronic tube in which some of the elements are movable.
- Here, the plates are mounted on an arm which extends through a flexible diaphragm in the end of the tube.
- A mechanical movement applied to the external end of the rod is transferred to the plates within the tube thereby changing the characteristics of the tube.

Applications:

Electronic transducer element is used as surface roughness

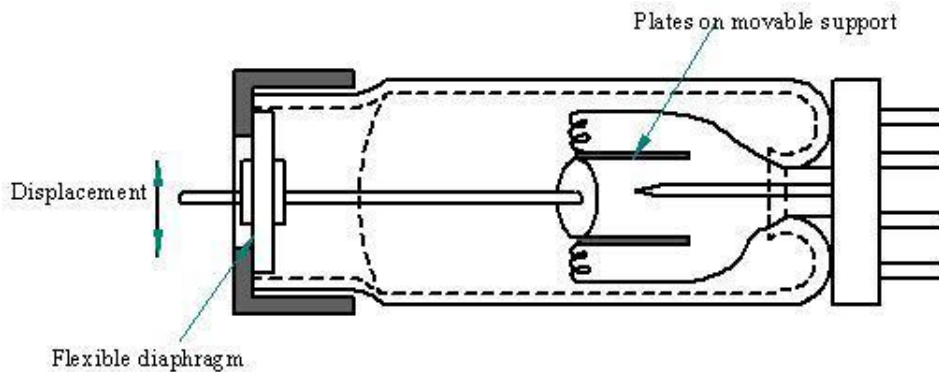

Electrokinetic Transducer

- The Electrokinetic phenomenon is also referred to as ‘Streaming Potential’ which occurs when a polar liquid such as water, Methanol, or acetonitrile (CH_3CN) is forced through a porous disc.
- When the liquid flows through the pores, a voltage is generated which is in phase with and directly proportional to the pressure across the faces of the disc.
- When direction of flow is reversed, the polarity of the signal is also reversed.

Electrokinetic Transducer

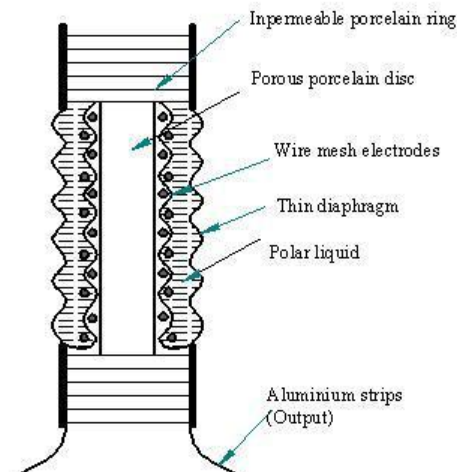

An unlimited supply of liquid is required on the upstream to measure static differential pressure with this type of pickup. Since this is impractical, finite amount of liquid is constrained within the electrokinetic cell. i.e. the device is used for dynamic rather than static pressure measurements.

- *Fig. shows a typical electrokinetic cell. It consists of a porous porcelain disc fitted into the center of an impermeable porcelain ring.*
- *The diaphragms are tightly sealed on either side to retain the polar liquid, which fills the space between the diaphragms.*
- *A wire mesh electrode is mounted on either side of the porous disc, with electrical connections via the aluminium strips.*
- *The whole assembly is fitted in a suitable housing.*

Applications: Measurement of small dynamic displacements, pressure & acceleration. **Limitations:** Can not be used for measurement of static quantities.

OUTCOMES

Students will understand

1. Concept of measurements and measuring devices.
2. Concept of transducers.

SELF ASSESMENT QUESTIONS

1. What is the difference between active and passive sensors and continuous and discrete sensors?
2. Briefly explain the principles of operation of limit switch, proximity switch and photoelectric sensors.

FURTHER READING

1. Jain R. K., 1997, Engineering Metrology, Khanna Publishers.
2. Shawne A. K., 1998, Mechanical Measurement and Instrumentation, Dhanpat Rai and Co. (P) Ltd.
3. Hazra Chowdhury, 1995, Workshop Technology, Media Promoters and Publishers Pvt. Ltd