

## Module -1

### CAUSES OF ENERGY SCARCITY

The world is facing energy scarcity. Several countries including India are facing various associated difficulties for its techno-socio-economic development because of energy shortage. The development is affected due to the energy dependence on the other countries. Energy use scenario of the present indicates that social and economical equality cannot be achieved, when 30% population is utilizing 70% of energy and 70% population is forced to live with the 30% of the remaining energy.

Following points may be considered as the principal causes of energy scarcity

#### 1. Increasing Population

Worldwide population is increasing at an alarming rate. It is expected that by the turn of 21st century, population will increase manifold. These populations are unevenly distributed worldwide. Africa shares the largest population growth rate, followed by South Asia and then by Europe.

#### 2. Increasing Energy Usage or Consumption

The civilization from early man to the present technological man was totally based on energy usage. Energy is constantly used at home, at work, and for leisure period of enjoyment. Energy maintains techno-socio-economic development. Energy provides the society electricity daily and motivates power to industry, transportation and modern way of life. Consumption includes

1. In homes, for lighting and cooking, domestic appliances, televisions, computers, etc.
2. In industry to power manufacturing of the products.
3. In transport system to power cars, trucks, ships, for transporting people and goods.

An increase in the world population and consequent increase in energy consumption increases energy demands manifold. World Energy Council has provided the most reliable prediction as that indicates that by [2050](#), the world population will nearly be doubled from the present level and will rise to about 10 billion. Likewise, energy demand is projected to be at least double than the present level.

#### 3. Uneven Distribution of Energy Resources

It is well known that very few wealthy countries have access to and actually use the largest part of the world's energy and material resources. The generation of environmental and social instability in several areas of the globe can be related to the existence of disparity, uneven distribution of energy and resource trade among countries is of great importance to environmental and political stability.

For example, Middle East countries are full of crude oil reserves, but they are forced to involve in conflicts and wars and their energy reserves are forcefully used by wealthy countries. Geographical distribution is the main consideration for an uneven distribution of fossil fuels (coal, oil, gas, and nuclear). Renewable energy flows are also spread out unevenly. Cloudiness in equatorial regions reduces solar radiation. Whole stretches of the continent have insufficient wind. There are very few sites with the best potential for geothermal, tides, or ocean thermal. In fact, a few densely populated region or area have no significant locally available energy sources at all.

#### 4. Lacks of Technical Knowledge

Several countries or regions are having energy in abundance but they are not able to fully utilize them due to the lack of knowledge of conversion, transmission, distribution, the lack of technical knowledge. Resources are mined and processed in resource enriched countries and then refined and used in developed countries. The price of exported resources is normally inadequate to compensate for the depletion of energy reserves and the environmental burden generated by resource extraction and primary processing in energy enriched countries. However, resources significantly contribute for economic benefits in techno-economically developed countries.

### SOLUTION TO ENERGY CRISIS OR SCARCITY

Owing to the growing importance of energy needs, efforts should be systematically diverted in the following directions to tackle energy scarcity problems

1. Minimizing population growth exploitation and harnessing the large utilization of known and unknown energy reservoirs.
2. Development of energy conversion techniques to convert basic energy available from energy reservoirs (primary energy resources) to usable form of energy (secondary resources). Usable energy form should be such that it is easy to generate, control, transport and utilize. Electrical energy being the only usable form of energy to meet all these at present.
3. Keep the new energy system pollution free as far as possible, thereby environmentally acceptable to human beings
4. The development of cheap and reliable energy storage systems. Maintaining new energy development program that is independent of foreign impact to the extent is possible.
5. Energy management

## FACTORS AFFECTING ENERGY RESOURCE DEVELOPMENT

Examination of certain basic principles of energy availability studies reveals the following five factors that make energy resource development more difficult are

### 1. Energy or Fuel Substitution or Scale of Shift

Today, there is no readily available energy resources that is large enough to substitute for fossil fuels (coal, oil, gas, and nuclear) at requisite scale. Undoubtedly, solar energy is several orders of magnitude larger than any conceivable global energy demand. Practical conversion to electricity using photovoltaic or large scale industrial heat are quite negligible.

### 2. Energy Density

The amount of energy contained in a unit of material object (energy resource) is termed as energy density. Air-dry crop residue (mostly straw and agricultural waste) contain only [12-15 MJ/kg](#)

For example, the energy density of good quality coal is twice as high (i.e. [25-30](#) MJ/kg) as oil (i.e., [42-45](#) MJ/kg). In order to obtain an equivalent output, replacement of a unit of fossil fuels with approximately 2 kg of phytomass will be needed to substitute solid biofuel. The ratio would be about [1.5](#) times when substituting plant-derived ethanol for petrol. These realities would be reflected in the reserve capacity, cost, and operation of the required infrastructure.

### 3. Power Density

Power density refers to the rate of energy production per unit of earth's area and usually expressed in watts per square meters. Owing to lengthy period of formation (from biomass to coal and then from coal to hydrocarbons), fossil fuel deposits are an extraordinarily concentrated source of high quality energy.

In contrast, biomass energy production has densities of 1 watt per meter square. while density of electricity produced by water and wind is below 10 w/m<sup>2</sup>. Only photovoltaic electricity generation can deliver larger than 20 w/m<sup>2</sup>. [although](#) the cost and performance are the constraints.

### 4. Intermittency

Growing demand for fuels, energy, and electricity fluctuates daily and seasonally in modern civilization. Further, the base load, which is defined as the minimum energy required meeting the demand of the day, has been increasing. Easily storable high-energy density fossil fuels and thermal electricity generating stations that are capable of operating with high load factors meet these needs.

On the other hand, wind and direct solar radiation are intermittent and far from practicable. They can never deliver such high load factors. Photovoltaic electric generation is still so negligible to offer any meaningful average with relatively large capacities are 20-25%. Unfortunately, we still lack the means for storing wind or solar-generated electricity on a large scale.

## 5. Geographical Energy Distribution

'As already mentioned, there are uneven distributions of fossil fuels and the non-fossil fuels. Cloudiness in the equatorial zone reduce direct solar radiation. Whole stretches of continent has insufficient wind. There are very few sites with the best potential for geothermal, tidal, or ocean energy conversions.

## ENERGY RESOURCES AND CLASSIFICATION

The following sections deals with the classification of promising energy resources of immediate interests

### 1. Primary and Secondary Energy Resources

1. Primary energy resources are derived directly from natural reserve. Examples are chemical solar, wind, geothermal, nuclear hydropower, etc. They are used either in basic raw energy form or by converting them to usable form (secondary energy). Secondary energy resources are usable forms of energy generated by means of suitable plants to convert the primary energy. Examples are electrical energy, steam power, hot water power, hydrogen energy.

Usable form of energy is cost effective, highly efficient with improved performance, environmentally acceptable and system acceptability index approaching to unity is achievable during conversion, transportation, distribution, and end use. From the abovementioned viewpoints, Electrical energy will continue to be dominant.

Primary energy resources may be further sub-classified as follows

1. Conventional and non-conventional energy resources: (a) Conventional energy resources and their technical knowledge are known to mankind to a great extent. They are the energy stored within the earth and the sea. They include both fossil fuels (coal, oil, and gas) and clear energy (uranium and thorium) and required human intervention to release the energy from them. These sources have formed over hundreds of millions of years ago and when they are used, there will be no more for future generations. They are also known as finite energy resources. (b) Non-conventional energy resources are also known as infinite energy resources. Their technical knowledge is little known and they need full exploitation and improved technical understanding. However, it may be mentioned that owing to the cost factor and overall performance, one may think of utilizing all these energy resources only when all the conventional energy resources have been fully exploited and utilized. They are obtained from the energy flowing through the natural environment. It is necessary to note that the energy is passing through the environment as a current or as a flow and whether there is an artificial device there to intercept and harness the power or not. Further, it is important to know the rate at which useful energy can be obtained from these sources.

2. Renewable and non-renewable energy resources: (a) Renewable energy resources are continuously restored by nature. Examples are solar, water, wind, etc. (b) Non-renewable energy resources are the reserve that is once accumulated in nature has practically ceased to form under new geological conditions. They are also known as expendable energy. Examples are gas, nuclear, etc.

## 2. Oil

Oil companies estimate that the world's proven oil reserves are about [1,050](#) thousand million barrels (BP [2002](#)). This is equivalent to about [6.4](#) x [1,021](#) J or [6,400](#) exajoules. Estimates of reserves are always subject to uncertainty and change. There is a very uneven distribution of oil reserves across the world, with some 71% of proven oil reserves being in the Middle East. The ultimately recoverable and unconventional reserves are very much more difficult to specify. The estimates of additional reserves that will be found and the growth to existing fields will vary widely. However, there is general agreement that crude oil is a finite resource that will run short and may sometime become very expensive in the first half of this century

## 3. Natural Gas

The proven reserves of natural gas are presently some [152](#) trillion cubic meters (about [5.9](#) x [1.021](#) Joules or [5,900](#) exajoules). This is about the same as the reserves of oil. However, because gas is more difficult to transport and trade, there has not been as much effort is put into finding gas when compared with that of finding oil. There are some prospective regions of the world that have not been fully explored. Technologies for extracting gas constantly improve, thus making it difficult to estimate the sizes of the gas fields. The [2001](#) world gas consumption rate of [2.5](#) trillion cubic meters per annum (The World Fact book) has doubled over the last 30 years, while oil consumption has only increased some 30%.

## 4. Coal

In [1999](#), the proved recoverable reserves of coal is around one million tonnes [The World Energy Council estimates]. There is much more coal than any other fossil fuel. This is equivalent to a  $3 \times 10^{10}$  J or [30,000](#) exajoules; this is enough to sustain present production for more than years. The world's consumption of coal is still rising (at less than 1% a year), but industrial countries over recent decades have decreased their dependence on coal. The use of coal is limited More by environmental considerations than by the size of the resource. modern techniques for burning coal using liquefaction and gasification processes can greatly reduce some of the pollutants from coal. However, coal always produces a great deal of carbon dioxide (greenhousegas). There had been no cost-effective way developed for capturing and sequestering this carbon dioxide, but extensive research programs are underway

## 5. Uranium

The economically accessible reserves of natural uranium were estimated by the World Energy Council in [1999](#) at three million tonnes. In the [1970s](#), this was expected to last no more than a few decades, but due to the slower grown than the expected growth in the nuclear industry and increased availability of uranium and the decommissioning of nuclear weapons, this time frame

has been extended. There are public reservations about the cost and the safety of nuclear power plants, but they produce almost no CO<sub>2</sub> and the technology is mature

## 6. Hydroelectric power

At present, hydroelectricity provides the second biggest renewable energy contribution to world energy supply, with an annual output of 2,600 TWh. Information received from energy sources indicates that the world's total technically feasible hydro potential is about 14,400 TWh/yr, out of which just over 8,000 TWh/yr is currently considered to be economically feasible for development.

Hydropower is dependent on rainfall, and climate change could affect this potential. There is considerable opposition to the building of large dams for social and environmental reasons.

## RENEWABLE ENERGY

Renewable energy is the energy that comes from natural resources such as sunlight, wind, rain, tides, and geothermal heat, which are renewable (naturally replenished). The availability of the renewable energy resources is discussed in the following sections

### 1. Worldwide Renewable Energy Availability

Of global final energy consumption comes from renewable with 10% coming from traditional biomass, which is mainly used for heating, and 3.4% from hydroelectricity.

#### 1. Renewable power excluding hydro

#### 2. Wind

#### 3. Biomass

#### 4. Solar photovoltaic

#### 5. Geothermal

New renewable energy (small hydro, modern biomass, wind, solar, geothermal, and biofuel) accounted for another 3% and were growing very rapidly. The share of renewable energy in electricity generation is around 19%, with 16% of global electricity coming from hydroelectricity, and 3% from new renewable energy.

## **Module -2**

### **SOLAR THERMAL SYSTEMS**

#### **INTRODUCTION**

1. "Drying is an excellent way to preserve food and solar food dryers are an appropriate food preservation technology for a sustainable world." Actually, solar food drying is one of the oldest agricultural techniques related to food preservation,
2. Drying of crops can change this trend and is useful in most areas of the world, especially those without a high humidity during the harvesting season. If drying of produce were widely implemented, significant savings to farmers would be achieved. These savings could help strengthen the economic situation of numerous developing governments as well as change the nutritional condition in these same countries. Unfortunately many of the areas that could benefit from solar drying technology lack adequate information related to how to employ this technology and which technology to use under specific conditions. Many of the latest developments in solar drying technology, as well as significant achievements through applying this body of knowledge are not available in libraries or the Universities of developing countries. However, modern science has provided a new resource that helps bridge this information void. The World Wide Web, commonly know as the INTERNET can provide the solution to rapidly spreading new information and applications of known information into areas of greatest need.

**Physical principles of the conversion of solar radiation into heat:**

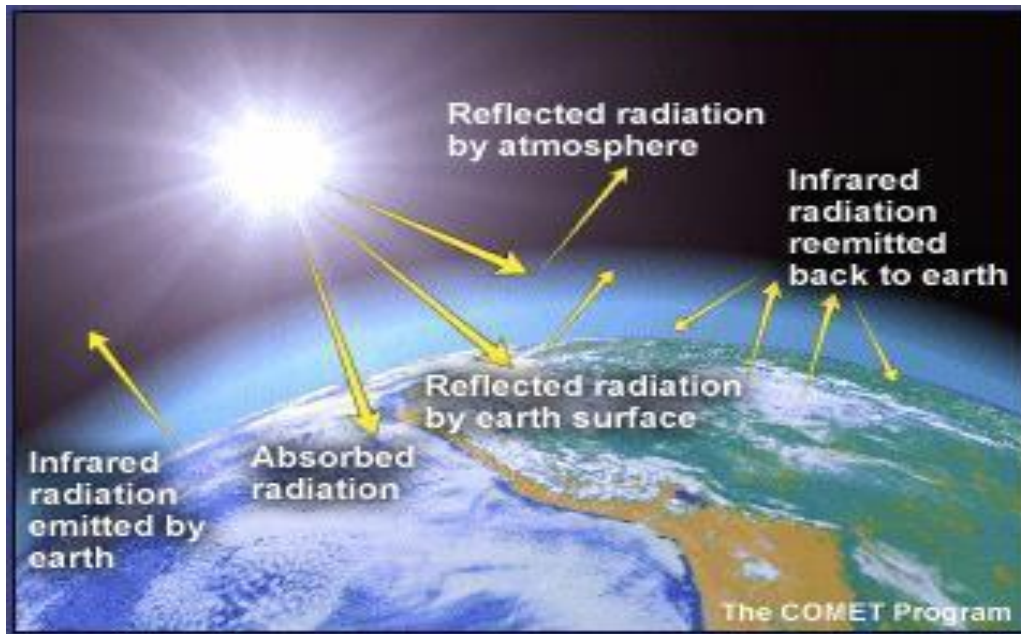

1. Green houses are useful for growing and propagating plants because they both allow sunlight to enter and prevent heat from escaping.
2. The transparent covering of the greenhouse allows visible light to enter unhindered, where it warms the interior as it is absorbed by the material within. The transparent covering also prevents the heat from leaving by reflecting the energy back into the interior and preventing outside winds from carrying it away.
3. Like the greenhouse covering, our atmosphere also serves to retain heat at the surface of the earth. Much of the sun's energy reaches earth as visible light. Of the visible light that enters the atmosphere, about 30% is reflected back out into space by clouds, snow and ice-covered land, sea surfaces, and atmospheric dust. The rest is absorbed by the liquids, solids, and gases that constitute our planet.
4. The energy absorbed is eventually reemitted, but not as visible light (only very hot objects such as the sun can emit visible light). Instead, it's emitted as longer-wavelength light called infrared radiation. This is also called "heat" radiation, because although we



cannot see in infrared, we can feel its presence as heat. This is what you feel when you put your hand near the surface of a hot skillet.

5. Certain gases in our atmosphere (known as "trace" gases because they make up only a tiny fraction of the atmosphere) can absorb this outgoing infrared radiation, in effect trapping the heat energy. This trapped heat energy makes the earth warmer than it would be without these trace gases.
6. The ability of certain trace gases to be relatively transparent to incoming visible light from the sun yet opaque to the energy radiated from earth is one of the best-understood processes in atmospheric science. This phenomenon has been called the "greenhouse effect" because the trace gases trap heat similar to the way that a greenhouse's transparent covering traps heat. Without our atmospheric greenhouse effect, earth's surface temperature would be far below freezing. On the other hand, an increase in atmospheric trace gases could result in increased trapped heat and rising global temperatures.

### **Flat plate Collectors:**

1. Made of rectangular panels (1.7 to 2.9 Sq.m)
2. Simple to construct and erect.
3. Can collect and absorb both direct and diffuse radiations
4. Flat plate solar collectors classified into two types based on the type of heat transfer fluid
  1. Liquid heating collectors are used for heating water and nonfreezing aqueous solutions ( rarely Non aqueous solutions)
  2. Air or gas heating collectors are employed as solar air heaters.

### **Basic Components of Flat plate collectors:**

1. A transparent cover which may be one or more sheets of glass or radiation transmitting plastic film or sheets.
2. Tubes, fins, passages or channels are integrate with the collector absorber plate or

connected to it, which carry the water, air or other fluids.

3. The absorber plate, normally metallic or with a black surface although a wide variety of other materials can be used with air heaters.
4. Insulation, Which should be provided at the back and sides to minimize the heat losses. (fiber glass or styro-foam)
5. The casing or container which enclose the other components and protects them from the weather.

### Collectors

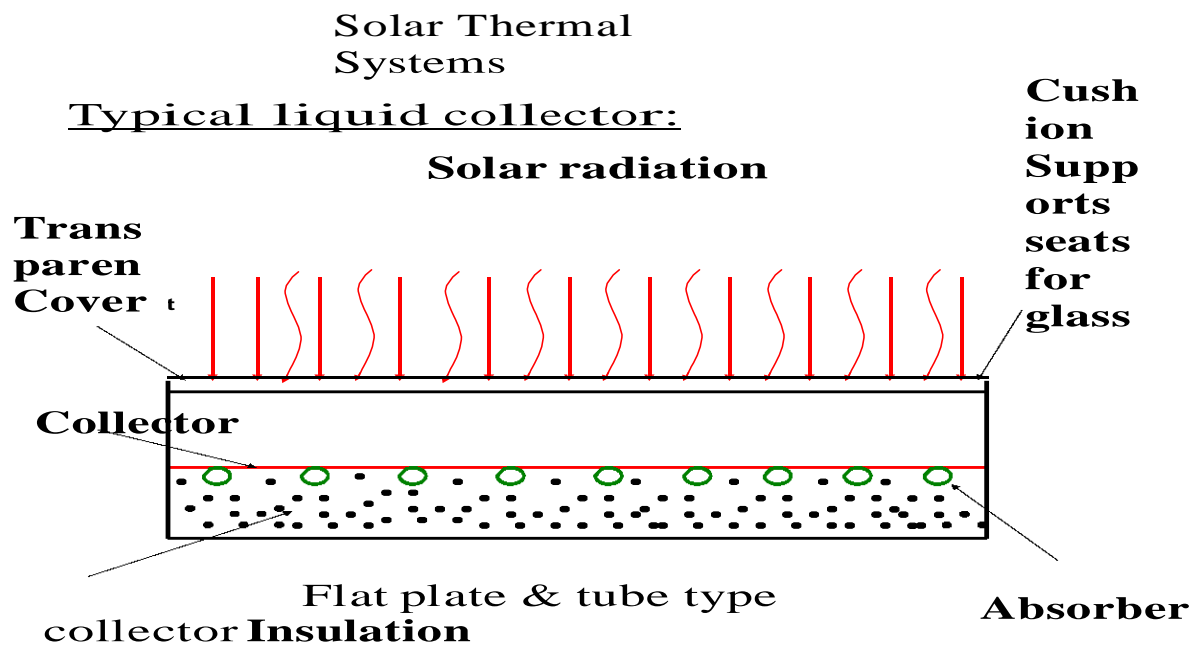

**Advantages of Flat plate collector:**

1. Of using both beam and diffuse solar radiations
2. They do not require orientation towards the sun
3. They require little maintenance.
4. Mechanically simpler than the concentrating reflectors, absorbing surfaces and orientation devices of focusing collectors

**Drawbacks of using water as fluid:**

1. Freezing in the collector tubes in the cold climates during cold nights. (ethylene glycol is added to prevent)
2. Corrosion of the metal tubes

**Air collector or solar air heaters****Applications:**

1. Heating buildings
2. Drying agricultural produce and lumber.
3. Heating green houses
4. Air conditioning (refrigeration process)
5. Heat sources for a heat engine

**Concentrating Collector:**

1. Focusing Collector is a device to collect solar energy with high intensity of solar radiation on the energy absorbing surface. Optical system in the form of reflectors or refractors are used.
2. A focusing collector is a special form of flat plate collector modified by introducing a reflecting surface between the solar radiators and absorber.
3. Radiation increases from low value of 1.5-2 to high values of the order of 10,000.

4. Radiation falling on a relatively large area, is focused on to a receiver (or absorber) of considerably smaller area.
5. Fluid can be heated to temperature of  $500^{\circ}\text{C}$  or more.

**Types of Concentrating Collectors:**

1. Depending on concentrating, collectors may classified as
  1. Line focusing and
  2. Point focusing

As per the no. of concentrating collector geometries, the main types of concentrating collector are

1. Parabolic through collector
2. Mirror strip reflector
3. Fresnel lens collector
4. Flat plate collector with adjustable mirrors
5. Compound parabolic concentrator (C.P.C)

### **Line focusing collectors (Parabolic through reflector)**

1. Solar radiation coming from the particular direction is collected over the area of the reflecting surface and is concentrated at the focus of the parabola, if the reflector is in the form of a trough with parabolic cross-section, the solar radiation is focused along a line.
2. Mostly cylindrical parabolic concentrators are used, in which absorber is placed along focus axis.

Parabolic through reflectors have been made of highly polished aluminum, of silvered glass or of a thin film of aluminized plastic on firm base

### **Mirror strip Reflector:**

1. Slightly curved mirror strips are mounted on a flat base.
2. The angles of the individual mirrors are such that they reflect solar radiation from a specific direction on to the same focal line.
3. Angles of the mirrors must be adjusted to allow for changes in the sun's elevation, while the focal line remains in a fixed position.

### **Pointed Focusing collector (Paraboloidal type)**

1. Absorber located at the focus is a cavity made of zirconium-copper alloy with black chrome selective coating.
2. The heat transport fluid flows into and out of the absorber cavity through pipe bonded to

the interior.

**Advantages and Disadvantages of concentrating collectors over flat Plate type collectors:**

**Advantages:**

1. Reflecting surfaces require less material and are structurally simpler than flat plate collectors. (less cost )
2. The absorber area of a concentrating system is smaller than that of a flat plate system for same solar energy collection.

3. Loss of energy after collecting is less than FPC, because of large absorber area in FPC, working fluid can attain higher temperature.
4. Owing to the small area of absorber per unit of solar energy collecting area, selective surface treatment and/or vacuum insulation to reduce heat losses and improve collector efficiency are economically feasible.
5. Can be used for electricity power generation.
6. Heat storage costs are less
7. Little or no anti freeze is required to protect the absorber.
8. It is possible to get higher efficiencies.

**Disadvantages:**

1. Only beam component is collected.
2. Costly oriented systems
3. Additional requirements of maintenance is required.
4. Non uniform flux on the absorber.
5. Additional optical losses such as reflectance loss and the intercept loss, so they introduce additional factors in energy balances.
6. High Initial cost.

**Solar furnace cookers:**

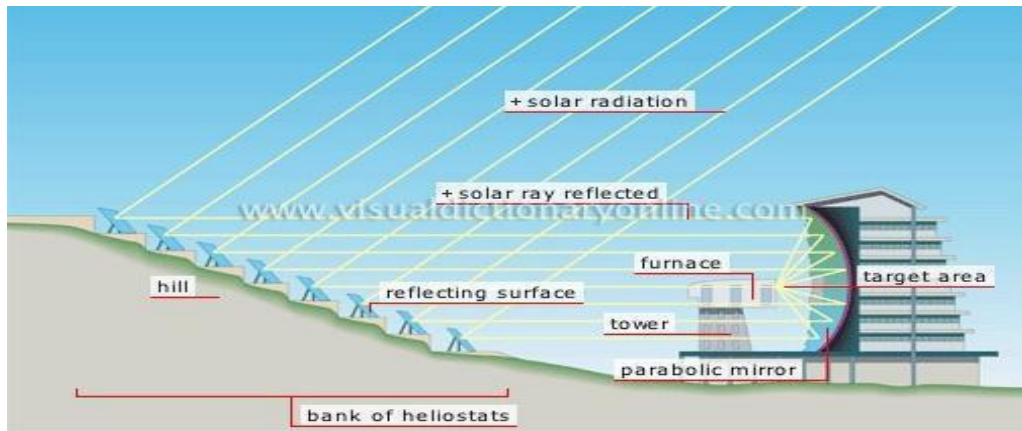



## Solar Thermal Systems

### Solar cooking:

- Basically there are three designs of solar cooker
1. Flat plate box type
  2. Multi reflector type solar oven and
  3. Parabolic disc concentrator type solar cooker

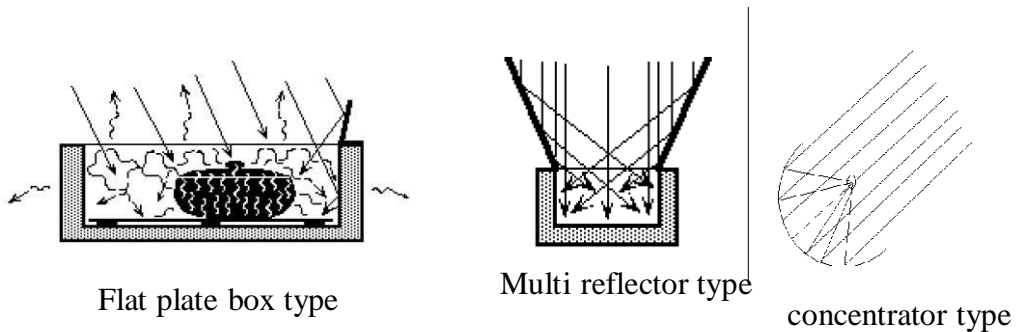

## Solar Thermal Systems

### Box type Cooker:

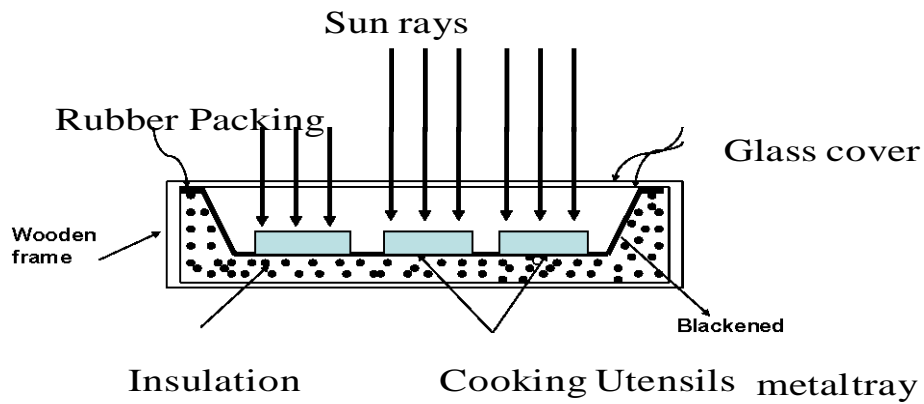

**ooker:**

1. The solar rays penetrate through the glass covers and absorbed by a blackened metal tray kept inside the solar box.
2. The solar radiation entering the box are of short wave length.
3. The higher wave length radiation is not able to pass through the glass cover i.e reradiation from absorber plate to outside the box is minimized to gain minimize the heat loss.
4. Rubber strips are used to reduce the loss.
5. Insulation material like glass wool, paddy husk, saw dust are used.
6. A solar box cooks because the interior of the box is heated by the energy of the sun.
7. Sunlight, both direct and reflected, enters the solar box through the glass or plastic top. It turns to heat energy when it is absorbed by the dark absorber plate and cooking pots. This heat input causes the temperature inside of the solar box cooker to rise until the heat loss of the cooker is equal to the solar heat gain.
8. Temperatures sufficient for cooking food and pasteurizing water are easily achieved.

**Merits of Solar cooker:**

1. No attention is needed during cooking
2. No fuel is required.
3. Negligible maintenance cost
4. No pollution
5. Vitamins of the food are not destroyed
6. No problem of charring of food and no overflowing

**Limitations:**

1. One has to cook according to the sun shine, menu has to be preplanned.
2. One cannot cook at short notice and food cannot be cooked in the night or during cloudy days.
3. It takes comparatively more time.
4. Chapatias are not cooked because high temperature is required and also needs manipulation at the time of baking

## SOLAR ELECTRIC SYSTEMS

### Solar Still:

1. The basic principles of solar water distillation are simple yet effective, as distillation replicates the way nature makes rain.
2. The sun's energy heats water to the point of evaporation. As the water evaporates, water vapor rises, condensing on the glass surface for collection.
3. This process removes impurities such as salts and heavy metals as well as eliminates microbiological organisms. The end result is water cleaner than the purest rainwater.
4. The SolAqua still is a passive solar distiller that only needs sunshine to operate. There are no moving parts to wear out.
5. Solar stills use natural evaporation and condensation, which is the rainwater process. This allows for natural pH buffering that produces excellent taste as compared to steam distillation.
6. Solar stills can easily provide enough water for family drinking and cooking needs.
7. Solar distillers can be used to effectively remove many impurities ranging from salts to microorganisms and are even used to make drinking water from seawater.
8. SolAqua stills have been well received by many users, both rural and urban, from around the globe. SolAqua solar distillers can be successfully used anywhere the sun shines.
9. The SolAqua solar stills are simple and have no moving parts. They are made of quality materials designed to stand-up to the harsh conditions produced by water and sunlight.
10. Operation is simple: water should be added (either manually or automatically) once a day through the still's supply fill port. Excess water will drain out of the overflow port and this will keep salts from building up in the basin.
11. Purified drinking water is collected from the output collection port.

## Solar Thermal Systems

### Solar Distillation: (solar still)

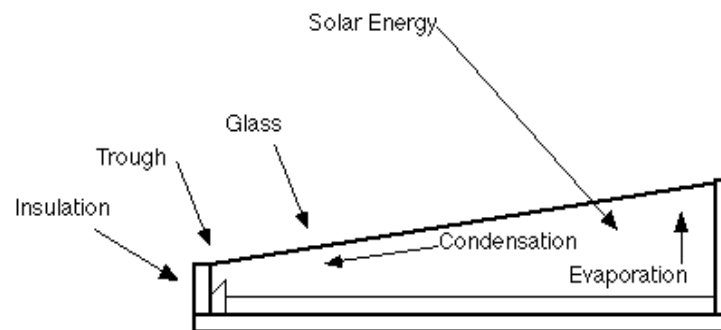

## **SOLAR DRYING**

Drying preserves foods by removing enough moisture from food to prevent decay and spoilage. Water content of properly dried food varies from 5 to 25 percent depending on the food. Successful drying depends on:

- enough heat to draw out moisture, without cooking the food;
- dry air to absorb the released moisture; and
- adequate air circulation to carry off the moisture.

When drying foods, the key is to remove moisture as quickly as possible at a temperature that does not seriously affect the flavor, texture and color of the food. If the temperature is too low in the beginning, microorganisms may grow before the food is adequately dried. If the temperature is too high and the humidity too low, the food may harden on the surface. This makes it more difficult for moisture to escape and the food does not dry properly. Although drying is a relatively simple method of food preservation, the procedure is not exact.

**lar Driers:**

1. In many countries of the world, the use of solar thermal systems in the agricultural area to conserve vegetables, fruits, coffee and other crops has shown to be practical, economical and the responsible approach environmentally.
2. Solar heating systems to dry food and other crops can improve the quality of the product, while reducing wasted produce and traditional fuels - thus improving the quality of life, however the availability of good information is lacking in many of the countries where solar food processing systems are most needed.

**Solar green houses**

Greenhouses are used extensively by botanists, commercial plant growers, and dedicated gardeners. Particularly in cool climates, greenhouses are useful for growing and propagating plants because they both allow sunlight to enter and prevent heat from escaping. The transparent covering of the greenhouse allows visible light to enter unhindered, where it warms the interior as it is absorbed by the material within. The transparent covering also prevents the heat from leaving by reflecting the energy back into the interior and preventing outside winds from carrying it away.

Like the greenhouse covering, our atmosphere also serves to retain heat at the surface of the earth. Much of the sun's energy reaches earth as visible light. Of the visible light that enters the atmosphere, about 30% is reflected back out into space by clouds, snow and ice-covered land, sea surfaces, and atmospheric dust. The rest is absorbed by the liquids, solids, and gases that constitute our planet. The energy absorbed is eventually reemitted, but not as visible light (only very hot objects such as the sun can emit visible light). Instead, it's emitted as longer-wavelength light called infrared radiation. This is also called "heat" radiation, because although we cannot see in infrared, we can feel its presence as heat. This is what you feel when you put your hand near the surface of a hot skillet. Certain gases in our atmosphere (known as "trace" gases because they make up only a tiny fraction of the atmosphere) can absorb this outgoing

infrared radiation, in effect trapping the heat energy. This trapped heat energy makes the earth warmer than it would be without these trace gases.

The ability of certain trace gases to be relatively transparent to incoming visible light from the sun yet opaque to the energy radiated from earth is one of the best-understood processes in atmospheric science. This phenomenon has been called the "greenhouse effect" because the trace gases trap heat similar to the way that a greenhouse's transparent covering traps heat. Without our atmospheric greenhouse effect, earth's surface temperature would be far below freezing. On the other hand, an increase in atmospheric trace gases could result in increased trapped heat and rising global temperatures.

### **Solar Photovoltaic:**

Photovoltaics (PV) is a method of generating electrical power by converting solar radiation into direct current electricity using semiconductors that exhibit the photovoltaic effect. Photovoltaic power generation employs solar panels composed of a number of solar cells containing a photovoltaic material. Materials presently used for photovoltaics include monocrystalline silicon, polycrystalline silicon, amorphous silicon, cadmium telluride, and copper indium gallium selenide/sulfide. Due to the growing demand for renewable energy sources, the manufacturing of solar cells and photovoltaic arrays has advanced considerably in recent years.

Solar photovoltaics have long been argued to be a sustainable energy source.[1] By the end of 2011, a total of 67.4 GW had been installed, sufficient to generate 85 TWh/year.[2] Solar photovoltaics is now, after hydro and wind power, the third most important renewable energy source in terms of globally installed capacity. More than 100 countries use solar PV. Installations may be ground-mounted (and sometimes integrated with farming and grazing) or built into the roof or walls of a building (either building-integrated photovoltaics or simply rooftop).

### **Solar cells:**

Photovoltaics are best known as a method for generating electric power by using solar cells to convert energy from the sun into a flow of electrons. The photovoltaic effect refers to photons of light exciting electrons into a higher state of energy, allowing them to act as charge carriers for an electric current. The photovoltaic effect was first observed by Alexandre-Edmond Becquerel in 1839.[7][8] The term photovoltaic denotes the unbiased operating mode of a photodiode in

which current through the device is entirely due to the transduced light energy. Virtually all photovoltaic devices are some type of photodiode.

Solar cells produce direct current electricity from sun light, which can be used to power equipment or to recharge a battery. The first practical application of photovoltaics was to power orbiting satellites and other spacecraft, but today the majority of photovoltaic modules are used for grid connected power generation. In this case an inverter is required to convert the DC to AC. There is a smaller market for off-grid power for remote dwellings, boats, recreational vehicles, electric cars, roadside emergency telephones, remote sensing, and cathodic protection of pipelines.

Photovoltaic power generation employs solar panels composed of a number of solar cells containing a photovoltaic material. Materials presently used for photovoltaics include monocrystalline silicon, polycrystalline silicon, amorphous silicon, cadmium telluride, and copper indium gallium selenide/sulfide.[9] Due to the growing demand for renewable energy sources, the manufacturing of solar cells and photovoltaic arrays has advanced considerably in recent year. Cells require protection from the environment and are usually packaged tightly behind a glass sheet. When more power is required than a single cell can deliver, cells are electrically connected together to form photovoltaic modules, or solar panels. A single module is enough to power an emergency telephone, but for a house or a power plant the modules must be arranged in multiples as arrays

Cells require protection from the environment and are usually packaged tightly behind a glass sheet. When more power is required than a single cell can deliver, cells are electrically connected together to form photovoltaic modules, or solar panels. A single module is enough to power an emergency telephone, but multiples as arrays

for a house or a power  
plant the modules must  
be arranged in

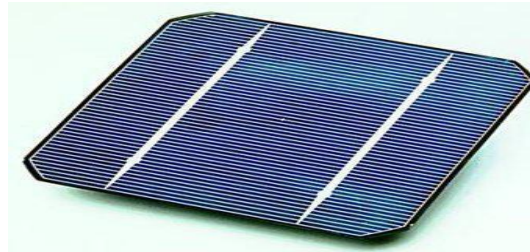



### **Classification of solar cell:**

The sun in one year can produce  $3.8 \times 10^{23}$ -kilowatt solar energy, is now equivalent to the entire mankind on earth, the total energy used in the  $6 \times 10^5$  billion times. Of these, about 1 / 22 billion to the solar radiation on Earth, the Earth is now equivalent to the total energy used by 30,000 times. Solar cells is a human use of solar energy devices, it is the use of solar photovoltaic effect should be directly converted into electrical energy, and only when the sunlight power generation only, therefore, must have a battery to store electricity. At present, the photo pool used for a silicon cell, the photoelectric conversion efficiency up to 11% to 14%. In addition, there are CdS battery, battery gallium arsenide, cadmium telluride, such as batteries. The use of solar equipment is also increasing, such as electronic calculators, watches, telephones, radios, tape recorders and so on, the price of commercial solar cells has dropped to below 4 U.S. dollars per watt. Solar cells more and more applications, more and more promising prospects. Solar cars, solar power, solar spacecraft, space solar power station, such as the use of solar energy research by the world's attention in general, are a number of countries in the field of energy in the future the focus of development. Some experts predict that solar cells will become the 21st century, one of the major sources of electricity.

### **Monocrystalline silicon solar cells:**

Series silicon solar cells, silicon cells can convert Dayang the most efficient, most mature technology. High-performance single crystal silicon cell is built on high-quality single crystal silicon and related materials into the thermal processing technology based on. Now the power to single crystal silicon technology has matured in recent in battery production, is generally used on the surface texture, firing passive zone, area, such as doping technology, the development of batteries are flat silicon cells and groove Monocrystalline silicon gate electrode buried in the battery. To improve the efficiency of conversion depends mainly on the surface of silicon micro-structure to deal with doping and zoning process. In this respect, Germany Fu Langhuo fee falaj Fort Solar System Research Institute maintains a leading position in the world. The technique photo-lithography technology to cell surface texture, made of inverted pyramid structure. And on

the surface of a 13nm. Thickness of the oxide layer passivation and two-reflection coating by the combination. By improving the process of electroplating the gate to increase the ratio of width and height: more than a battery system conversion efficiency over 23%, the largest value of up to 23.3 percent. Kyocera Corporation prepared a large area (225cm<sup>2</sup>) single-crystal solar cell power conversion efficiency of 19.44 percent for domestic Beijing Solar Energy Research Institute is also active high-performance crystalline silicon solar cell research and development, the development of high-performance single crystal silicon flat battery (2cm X 2cm) reached 19.79 percent conversion efficiency, the groove gate electrode buried in crystalline silicon cells (5cm X 5cm) up 8.6 percent conversion efficiency.

Monocrystalline silicon solar cell conversion efficiency is the highest in the large-scale application and industrial production is still dominant, but because of the single crystal silicon material prices and the cumbersome process of the batteries affected, resulting in high cost single crystal silicon At least, to a significant reduction in the cost is very difficult. In order to save high-quality materials, single crystal silicon cells to find alternative products, the development of the thin film solar cells, polysilicon thin film solar cells and thin film amorphous silicon solar cells is a typical representative.

### **Polysilicon thin film solar cells:**

The normally crystal silicon solar cells in the 350-450 $\mu$ m thickness of high-quality silicon made on this silicon or pulling from the casting of silicon ingots from the Juge. Therefore, the actual consumption of silicon material more. In order to save materials, from the mid-70 began in the low-cost polysilicon thin film deposited on the substrate, but because of the growth of silicon film grain size, not made of valuable solar cells. In order to obtain large-size grain of the film, people have never stopped, and a lot of ways. At present, preparation of polycrystalline silicon thin film batteries use chemical vapor deposition, including the low-pressure chemical vapor deposition (LPCVD) and plasma enhanced chemical vapor deposition (PECVD) process. In

addition, the liquid phase epitaxy (LPPE) and the sputtering deposition could be made available for preparation of polycrystalline silicon thin film batteries.

Chemical vapor deposition is the main  $\text{SiH}_2\text{Cl}_2$ ,  $\text{SiHCl}_3$ ,  $\text{SiCl}_4$  or  $\text{SiH}_4$ , as the reaction gas, a certain degree of protection in an atmosphere of silicon atoms to form and deposited on the substrate heating, the choice of substrate materials in general Si,  $\text{SiO}_2$ ,  $\text{Si}_3\text{N}_4$ , and so on. But the study found that in non-silicon substrates is difficult to form a larger grain, and easily form a gap between grain. To solve this problem is first in LPCVD substrate Shen Chi-thin layer of amorphous silicon layer, and then this layer of amorphous silicon layer annealing, the greater the grain, and then in this layer on the seed Thick polysilicon thin film deposition, recrystallization technology is a very important aspect of the current technology are solid-phase crystallization of the law and the Central re-melt crystallization. In addition to the polysilicon thin film batteries using the re-crystallization process, also used almost all of the preparation of single crystal silicon solar cell technology, such a system, the conversion efficiency of solar cells has increased remarkably. Germany falaj Fort Hall area using solar energy research institute recrystallization technology in the FZ Si substrate on a silicon-cell conversion efficiency of 19%, Japan's Mitsubishi with the preparation of the battery, the effective rate was 16.42 percent.

Liquid phase epitaxy (LPE) is a principle of law by molten silicon in its mother's body, the lower the temperature of precipitation silicon membrane. Astropower U.S. companies LPE Preparation of the battery efficiency of 12.2%. China photovoltaic technology development center Chen Zheliang LPE method used in the metallurgical grade silicon on a silicon crystal growth, and a design similar to the crystalline silicon thin film solar cells a new type of solar cells, known as the "silicon tablets of" solar energy Battery, but the performance has not yet seen the report.

As the polysilicon thin film batteries used in the silicon single crystal silicon than the less efficient and no recession, and there may be low-cost substrate material on the preparation, the cost much lower than the single crystal silicon cells, and more efficient than amorphous Silicon thin film battery, polysilicon thin film solar cells will soon be in power to dominate the market.

### **Amorphous silicon thin film solar cells:**

The development of solar cells on two key issues: the conversion to increase efficiency and reduce costs. As the amorphous silicon thin film solar cells, low cost, ease of large-scale production, generally people's attention and rapid development, in fact, as early as in the early 1970s, Carlson, and so began the development of amorphous silicon cells, during the past few In its development has been rapid development of the world's been many companies in the production of this type of battery products.

Although the material as amorphous silicon solar battery is a good material, but because of its optical band gap is 1.7eV, making their own materials on the long-wave solar radiation spectrum of the region is not sensitive, so restrictions on the amorphous silicon solar cells The conversion efficiency. In addition, the efficiency of the photoelectric light as an extension of time and decay, the so-called photo-induced recession of the S-W effect, making the battery performance of instability. To address these issues in this track is prepared laminated solar cells, solar cells are stacked in the preparation of p, i, n single-junction solar cell layer and then deposited on one or more sub-Pin of a battery system. Tandem solar cells increase the conversion efficiency of single-junction cells do not resolve the key to the stability of the problem is:

- ① it to a different band gap of Materials group with Taiwan, in response to the increased scope of the spectrum;
- ② top of the i-thin battery , The light produced by small changes in the electric field strength to ensure that i layer of photo-induced carriers out;
- ③ generated at the end of the battery carrier is about one-half of the battery, reducing the effect of photo-induced recession;
- ④ tandem solar cells each child Battery is a series together.

Amorphous silicon thin film solar cells have a lot of preparation, response, including sputtering, PECVD method, LPCVD law, the response of raw materials for gas H<sub>2</sub> diluted SiH<sub>4</sub>, and the glass substrate for the main piece of stainless steel, made of amorphous silicon Thin film battery

technology through a different process can be a single-node tandem solar cells and batteries. At present, amorphous silicon solar cells made major progress in the study: First, the laminated structure of the three amorphous silicon solar cell conversion efficiency of 13%, setting a new record; in the second. Laminated three annual production capacity of solar cells up to 5MW. United Solar Energy Company (VSSC) obtained the highest single-junction solar cell conversion efficiency of 9.3 percent for the third band gap cell stack three highest conversion efficiency of 13%. Above the highest conversion efficiency in a small area (0.25cm<sup>2</sup>) to get the battery. Had reported single-node amorphous silicon solar cell conversion efficiency of more than 12.5%, Academia Sinica, Japan adopted a series of new measures, a system of amorphous silicon cells for the conversion efficiency of 13.2 percent. With regard to domestic battery in particular, amorphous silicon thin film tandem solar cell research, Xinhua Geng's Nankai University, and other industrial materials used to back Al electrode prepared for the area 20X20cm<sup>2</sup>, to 8.28 percent conversion efficiency of a - Si / a-Si tandem solar cells. As the amorphous silicon solar cells with high conversion efficiency and low cost and light weight, and other features, has a great potential. At the same time, but because of its stability is not high, a direct impact on its practical application. If you can solve problems and improve the stability of the conversion rate, then the sun can be amorphous silicon cell is the main development of solar products. Solar photovoltaic cells (referred to as photovoltaic cells) used to direct the sun's light energy into electrical energy. At present, a large number of terrestrial photovoltaic system is based on the use of the silicon substrate for silicon solar cells can be divided into single crystal silicon, polycrystalline silicon, amorphous silicon solar cells. In the energy conversion efficiency and performance, and other aspects of life, better than the single crystal silicon and amorphous silicon cell battery. Polysilicon conversion efficiency is slightly lower than silicon, but the cheaper price.

In accordance with application requirements, solar cells go through a combination of up to the required output power and the rated output voltage of a group of photovoltaic cells, called photovoltaic components. According to the size and scale photovoltaic power plant, photovoltaic components can be composed of a variety of different size of the array.

The advent of the first single crystal silicon solar cells are solar cells. Silicon is the Earth is a

great deal of elements of a nearly everywhere silicon have a presence could be said to be inexhaustible. Used to manufacture silicon solar cells, has no shortage of raw materials. However, refining it is not easy, so people in the production of single crystal silicon solar cells at the same time, the polysilicon solar cell research and amorphous silicon solar cells, since commercial-scale production of solar cells, not yet out of a series of silicon. In fact, for the manufacture of solar cells, many semiconductor materials, with the materials industry, the solar cell will be more and more species. Has been At present, research & development of solar cells, with the exception of silicon series, there are CdS, gallium arsenide, copper indium selenium and many other types of list goes on, this election only a few of the more common solar cells for presentation.

#### **Monocrystalline silicon solar cell:**

Monocrystalline silicon solar cell is the fastest development of a solar cell, its structure and production technology have stereotypes, the products have been widely used in space and on the ground. This high purity of the single crystal silicon solar cells to stick to raw materials, the purity of 99.999 percent requirement. In order to reduce production costs, ground applications such as solar cells using solar-grade silicon rods, materials performance has been relaxed. Some also use semiconductor materials and processing of waste at the beginning and end silicon materials, rehabilitation and Latin America through the exclusive use of single crystal silicon solar cells made of sticks.

The single crystal silicon solar cell Tablets monomers made after a random test, according to the specifications required for assembly into a solar cell components (solar panels), serial and parallel with the method in some parts of the output voltage and current.

#### **Polycrystalline silicon solar cells:**

At present, the use of polysilicon solar cell materials, most of the particles contain a large number of single-crystal aggregates, or waste time silicon materials and metallurgical grade silicon material from melting casting, and then into the graphite mold, to be gradually cooling solidification , That is, a polycrystalline silicon ingots. This can make a cube of silicon ingots, in

order to slice processed into a square film solar cells, improve material utilization and to facilitate assembly. Polycrystalline silicon solar cell production process and almost single crystal silicon solar cell, its photoelectric conversion efficiency of about 12%, slightly lower than the single crystal silicon solar cells, but the material is simple, to save power consumption, with a total production costs than Low, it has been a large number of development.\

### **Amorphous silicon solar cell:**

Amorphous silicon solar cells in 1976 is the emergence of a new type of thin film solar cell type, with single crystal silicon and polycrystalline silicon solar cell production method is completely different, very little silicon material consumption, lower power consumption, is very attractive.

Amorphous silicon solar cells have different structures, of which there is a better structure called PiN battery, which is in the first substrate layer deposition of N-P-doped amorphous silicon and then a layer of sediment is not doped i Layer, and then deposited a layer of boron-doped amorphous silicon-based P, with the final electron beam evaporation by a layer of reflective film, and electrode silver evaporation. Such production process, a series of deposition chamber can be used in the production process constitutes a row in order to achieve high-volume production. At the same time, thin amorphous silicon solar cells can be made of laminated type, or integrated circuits produced in a plane, with the appropriate mask technology, the production of a number of batteries in series to achieve a higher voltage . Japan is now in series production of amorphous silicon solar cells up to 2.4 volts. Amorphous silicon solar cell problems in photoelectric conversion rate is low and unstable, so a lot yet to be used for large-scale solar power, for most, such as pocket-sized electronic calculators, electronic watches and clocks, and copiers, and so on.

### **Multi-compound solar cells:**

Multiple compounds refers to the solar cell is not a single element semiconductor materials

made of solar cells. Now a wide variety of national studies, though not yet the majority of industrial production, but indicates that the photoelectric conversion Spring garden. There are CdS solar cells, gallium arsenide solar cells, solar cells are several copper indium selenium.

### **Solar cells Condenser:**

Solar concentrator solar cells is to reduce the use of a measure of the total cost. By condenser result of larger-sun together in a small, to form the "focal" or "focal zone" and will put solar cells "focal" or "focal zone" in order to Increase in light intensity, solar radiation to overcome the shortcomings of low density and thus more power output. Concentrator is usually greater than the rate of a few dozen of its structure may or lens-reflex. Condenser's optical tracking with automatic tracking in general. Can be a way of cooling water or air, water heater and some combination of both access to electricity, hot water to be.

For condenser of monomer solar cells, solar cells and ordinary slightly different, because to be resistant to high-rate of solar radiation, particularly in the higher temperature of photovoltaic conversion performance to be assured that it is in the choice of semiconductor materials, batteries And the structure of the grid lines have to design some special consideration. The best material is gallium arsenide, followed by single crystal silicon material. In the cell structure, the general structure of the plane to make more use of solar cells, solar cells and condenser regular vertical structure in order to reduce the series resistance. At the same time, the condenser battery grid lines are more dense, typical of the condenser battery grid lines account for about 10% of the cell area to meet the high current density.

Solar cells have the type of single-crystal silicon and amorphous silicon, multi-crystalline silicon three categories, and most of the applications currently on the market for single-crystal silicon and amorphous silicon.

### **1. Single-crystal silicon solar cell**

The most common single-crystal silicon cells are used for power plants, charging systems, lighting and traffic signals, and so on, the electricity voltage and a wide range of high-efficiency, long service life, the world's leading manufacturers, such as Siemens of Germany, United



Kingdom Oil and Japan's Sharp are the production of such single-crystal silicon-based solar cells, as the market share of about five, single-crystal silicon cell efficiency from 11% to 24% of the space level (-evaporation) chip from 16% to 24% efficiency, of course, the higher the price of its more expensive.

## **2. Multi-crystalline silicon solar cell:**

Polysilicon cell efficiency than the low-single-crystal silicon, but the process step is relatively simple, low-cost, single-crystal silicon cell less than 20%, so some of the power of low-power applications using polysilicon solar cells

### **Solar characteristic:**

In solar cell applications this characteristic is usually drawn inverted about the voltage axis, as shown below. The cell generates no power in short-circuit (when current  $I_{sc}$  is produced) or open-circuit (when cell generates voltage  $V_{oc}$ ). The cell delivers maximum power  $P_{max}$  when operating at a point on the characteristic where the product  $IV$  is maximum. This is shown graphically below where the position of the maximum power point represents the largest area of the rectangle shown.

The efficiency ( $\eta$ ) of a solar cell is defined as the power  $P_{max}$  supplied by the cell at the maximum power point under standard test conditions, divided by the power of the radiation incident upon it. Most frequent conditions are: irradiance  $100 \text{ mW/cm}^2$ , standard reference spectrum, and temperature  $25^\circ \text{C}$ . The use of this standard irradiance value is particularly convenient since the cell efficiency in percent is then numerically equal to the power output from the cell in  $\text{mW/cm}^2$ .

**solar panel, module and array :**

Assemblies of photovoltaic cells are used to make solar modules which generate electrical power from sunlight. Multiple cells in an integrated group, all oriented in one plane, constitute a solar photovoltaic panel or "solar photovoltaic module," as distinguished from a "solar thermal module" or "solar hot water panel." The electrical energy generated from solar modules, referred to as solar power, is an example of solar energy. A group of connected solar modules (such as prior to installation on a pole-mounted tracker system) is called an "array."



Solar panel

Solar module and array

**Solar Photovoltaic Systems:**

Solar Photovoltaic System uses solar cells to convert light into electricity. A PV system consists of PV modules and balance of systems (BOS). Balance of systems includes module support structure, storage, wiring, power electronics, etc.

DC (direct current) electricity is generated when solar radiation strikes the PV module. Power can be used in any DC load directly during this generation. But the generation exists during daytime. So, some storage device is needed to run the system at night or in low sunshine hour. Again this power cannot be used to run any AC (alternate current) load. Inverter has to be used to convert D

Solar PV systems are categories into

Stand-alone PV systems (also called off-grid systems)

Grid connected PV systems (also called on-grid systems)

Hybrid systems

### **Stand-alone PV systems**

Stand-alone systems are not connected with utility power lines and these are self sufficient systems. These systems could either be used to charge the batteries that serve as an energy storage device or could work directly using the solar energy available in the daytimes. These systems consist of the following:

Solar panels mounted on the roof or in open spaces. Photovoltaic modules produce direct current (DC) electrical power.

Batteries to store DC energy generated by the solar panels.

Charge controller to prevent overcharging the battery.

Inverter to convert electricity produced by the system from DC to AC power.

The following diagram shows PV system powering AC loads with battery bank. DC loads can also be connected directly to the battery bank. It is also possible to power the AC load without battery, but in that case it would be confined only to daytime when solar radiation is sufficient to generate required electricity.

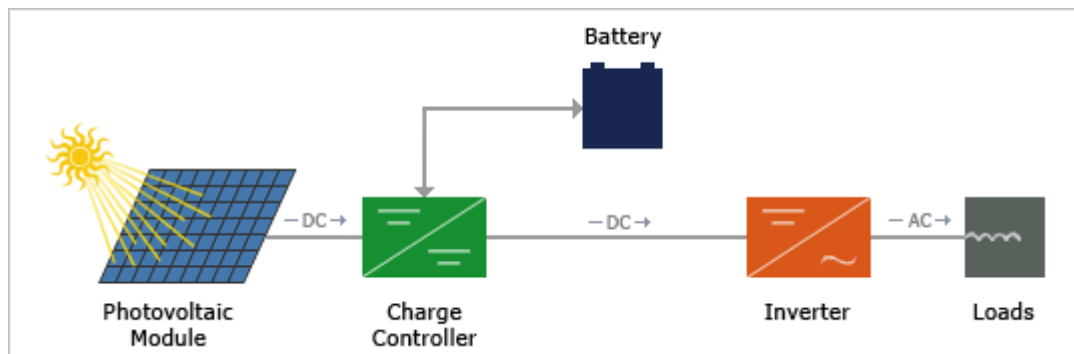

### Grid connected PV systems

A grid connected photovoltaic system will be interacted with utility grid. The main advantage of this system is that power can be drawn from the utility grid and when power is not available from grid, PV system can supplement that power. These grid connected systems are designed with battery or without battery storage. These systems consist of the following:

Solar panels mounted on the roof or in open spaces. Photovoltaic modules produce direct current (DC) electrical power.

Batteries to store DC energy generated by the solar panels.

Charge controller to prevent overcharging the battery.

Specially designed inverter to transform the PV generated DC electricity to the grid electricity (which is of AC) at the grid voltage.

The following diagram shows PV system powering AC loads. This system is connected to utility power supply and having battery storage for backup

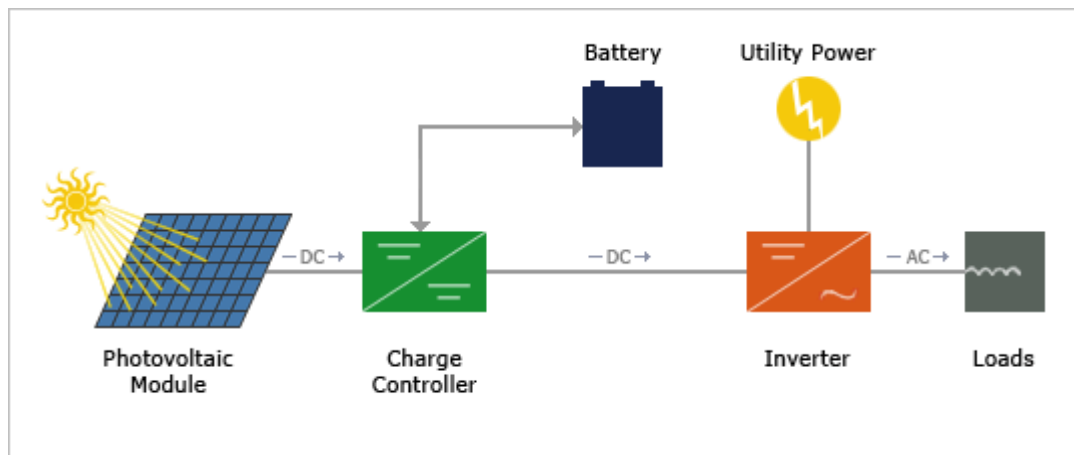

## Applications :

### Solar Lighting

A Solar lantern is a simple application of solar photovoltaic technology, which has found good acceptance in rural regions where the power supply is irregular and scarce. Even in the urban areas people prefer a solar lantern as an alternative during power cuts because of its simple mechanism. Home lighting System is powered by solar energy using solar cells that convert solar energy (sunlight) directly to electricity. The electricity is stored in batteries and used for the purpose of lighting whenever required. These systems are useful in non-electrified rural areas and as reliable emergency lighting system for important domestic, commercial and industrial applications. The SPV systems have found important application in the dairy industry for lighting milk collection/ chilling centers mostly located in rural areas.

Solar Street Light system is designed for outdoor application in un-electrified remote rural areas. This system is an ideal application for campus and village street lighting. The system is provided with battery storage backup sufficient to operate the light for 10-11 hours daily. The system is provided with automatic ON/OFF time switch for dusk to dawn operation and overcharge / deep discharge prevention cut-off with LED indicators.

## **Energy Storage**

### **Introduction:**

A type of thermodynamically force that is used to derive the system equally to do work is called as energy. There are different forms of in energy in different field of science such as physics and chemistry both have different forms of energy in their relevant fields which are used to derive their phenomena's separately. As we know that there are different Laws which explain that energy is neither created nor destroyed. As it is cleared that it is difficult to create energy for different appliances independently so, a method was used to reduce such condition of created the energy again that is called as energy storage.

### **Types of Energy Storage:**

There are lots of types which are used to store energy but there are three main types which are used to store energy for the long term use, theses types are as follows

Hydrogen cells

Batteries Fuel

tanks **Hydrogen**

### **Cells:**

An energy storing type that is used to store the energy in the form of hydrogen ions and then generate the power that is really free of environmental hazards to derive the working of different applications is called as hydrogen cell. This type can do the work more affectively as compared to other energy storing devices.

### **Batteries:**

A second type of energy storing device is called as battery, it is that type of device which can generate the power with the help different cells arrangement in a specific manner is called as battery. The cells which are arranged in the battery for working are

of two types that is primary cells and secondary cells.

### **Fuel Tanks:**

A special type of energy storing device that stores energy in the form of liquid, it is look like box that is filled with the flammable liquid i.e. mostly gasoline that is used by the engine to generate the energy and start the working, such device is called as fuel tank.

### **Methods of Energy Storage:**

There are many methods or ways to store energy, these methods really help us to store energy which is useful in our future to run different kind of systems. Energy storage methods are different in different fields of science such as chemistry, bio or physics etc. we can store energy by different types of methods which are chemically in nature such as energy storage by hydrogen, nitrogen in the liquid form etc. Energy can also store through the different kinds of mechanical methods such as hydraulic accumulator, fly wheel energy storage etc. sometimes energy storage can also done thermally such as ice storage, molten salts, hot bricks etc.

### **Importance of Energy Storage:**

There are lots of aspects which made the energy storage valuable or important for the mankind. Some of them are as follows

It plays an important part in power leveling.

It can increase the efficiency of the engine and increase the output.

It can change the low duty cycles into important ones.

## Module-3

# WIND ENERGY

### Introduction:

Winds are essentially created by the solar heating of the atmosphere. Several attempts have been made since 1940 to use wind to generate electric energy and development is still going on. However, techno-economic feasibility has yet to be satisfactorily established. Wind as a power source is attractive because it is plentiful, inexhaustible and non-polluting. Further, it does not impose extra heat burden on the environment. Unfortunately, it is non-steady and undependable. Control equipment has been devised to start the wind power plant whenever the wind speed reaches 30km/h. Methods have also been found to generate constant frequency power with varying wind speeds and consequently varying speeds of wind mill propellers. Wind power may prove practical for small power needs in isolated sites. But for maximum flexibility, it should be used in conjunction with other methods of power generation to ensure continuity. For a rotor of 17m diameter and a velocity of 48 km/h the theoretical power is 265kW and the practical would be roughly half of this value.

There are some distinctive energy end-use features of wind power systems:

Most wind power sites are in remote rural, island or marine areas. Rural grid systems are likely to be 'weak' in these areas, since they carry relatively low voltage supplies (e.g.33kV).

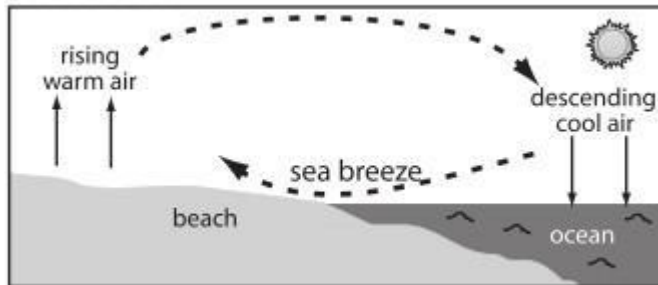
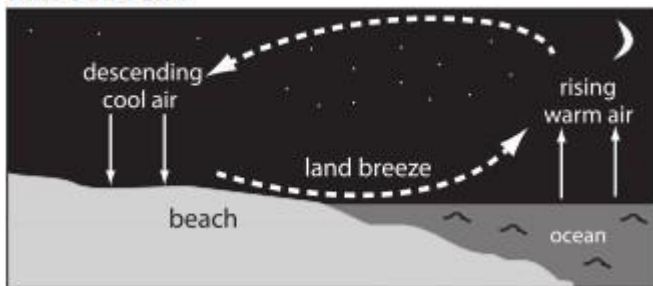

**Sea Breeze****Land Breeze****Wind energy:**

Can be economically used for the generation of electrical energy.

Winds are caused due to Heating and cooling of the main atmosphere which generates convection currents. The rotation of the earth with respect to atmosphere, and its motion around the sun. The potential of wind energy is abundant.  $1.6 \times 10^7$  MW. (Same order of present energy consumption) Wind mill is drives generator to produce electricity.

Water pumping for irrigation and drinking water Required Wind speed range is 8 to 36Km per hour In India, coastal areas of Saurashtra, western Rajasthan and some parts of central India.

**Wind Direction:**

A weather vane, or wind vane, is used to show the direction of the wind. A wind vane points toward the source of the wind. Wind direction is reported as the direction from which the wind blows, not the direction toward which the wind moves. A north wind blows from the north toward the south.

**Wind Speed:**

It is important in many cases to know how fast the wind is blowing. Wind speed can be measured using a wind gauge or anemometer. One type of anemometer is a device with three arms that spin on top of a shaft. Each arm has a cup on its end. The cups catch the wind and spin the shaft. The harder the wind blows, the faster the shaft spins. A device inside counts the number of rotations per minute and converts that figure into miles per hour. A display on the anemometer shows the speed of the wind.

**History of Wind Machines:**

Since ancient times, people have harnessed the wind's energy. Over 5,000 years ago, the ancient Egyptians used the wind to sail ships on the Nile River. Later, people built windmills to grind wheat and other grains. The early windmills looked like paddle wheels. Centuries later, the people in Holland improved the windmill. They gave it propellertype blades, still made with sails. Holland is famous for its windmills. In this country, the colonists used windmills to grind wheat and corn, to pump water, and to cut wood at sawmills. Today, people occasionally use windmills to grind grain and pump water, but they also use modern wind turbines to make electricity.

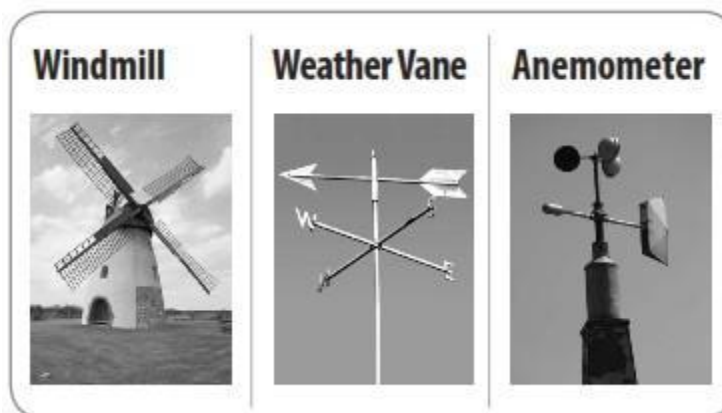

| Date           | Typical Capacity | Typical Blade Length | Typical Technology                                       |
|----------------|------------------|----------------------|--|
| Mid 1990s      | 400-500 kW       | 15-25 m              | Fixed rotational speed and fixed blade pitch angle       |
| 2000           | 1000 kW          | 25-35 m              | Dual rotational speed and fixed blade pitch angle        |
| Today          | 2000-3000 kW     | 35-45 m              | Variable rotational speed and variable blade pitch angle |
| Within 5 years | 3000-7000 kW     | 45-60 m              |  |

### Today's Wind Turbines:

Like old-fashioned windmills, today's wind turbines use blades to capture the wind's kinetic energy. Wind turbines work because they slow down the speed of the wind. When the wind blows, it pushes against the blades of the wind turbine, making them spin. They power a generator to produce electricity. Most wind turbines have the same basic parts: blades, shafts, gears, a generator, and a cable. (Some turbines do not have gearboxes.)

These parts work together to convert the wind's energy into electricity.

1. The wind blows and pushes against the blades on top of the tower, making them spin.
2. The turbine blades are connected to a low-speed drive shaft. When the blades spin, the shaft turns. The shaft is connected to a gearbox. The gears in the gearbox increase the speed of the spinning motion on a high-speed drive shaft.
3. The high-speed drive shaft is connected to a generator. As the shaft turns inside the generator, it produces electricity.
4. The electricity is sent through a cable down the turbine tower to a transmission line.

The amount of electricity that a turbine produces depends on its size and the speed of the wind. Wind turbines come in many different sizes. A small turbine may power one home.

Large wind turbines can produce enough electricity to power up to 1,000 homes. Large turbines are sometimes grouped together to provide power to the electricity grid. The grid is the network of power lines connected together across the entire country

### **Wind Power Plants:**

Wind power plants, or wind farms, are clusters of wind turbines used to produce electricity. A wind farm usually has dozens of wind turbines scattered over a large area. Choosing the location of a wind farm is known as siting a wind farm. The wind speed and direction must be studied to determine where to put the turbines. As a rule, wind speed increases with height, as well as over open areas with no windbreaks.

Turbines are usually built in rows facing into the prevailing wind. Placing turbines too far apart wastes space. If turbines are too close together, they block each other's wind. The site must have strong, steady winds. Scientists measure the winds in an area for several years before choosing a site. The best sites for wind farms are on hilltops, on the open plains, through mountain passes, and near the coasts of oceans or large lakes. The wind blows stronger and steadier over water than over land. There are no obstacles on the water to block the wind. There is a lot of wind energy available offshore. Offshore wind farms are built in the shallow waters off the coast of major lakes and oceans. Offshore turbines produce more electricity than turbines on land, but they cost more to build and operate. The first offshore wind farm in the United States, off the coast of Massachusetts, was approved in April 2011. Construction is expected to begin in 2013.

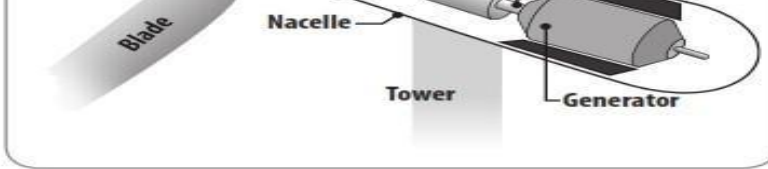

## **Wind Production**

Every year, wind produces only a small amount of the electricity this country uses, but the amount is growing every year. One reason wind farms don't produce more electricity is that they can only run when the wind is blowing at certain speeds. On Midwestern wind farms, the wind is optimum for producing electricity between 65 and 90 percent of the time.



## **Environmental Impacts**

In some areas, people worry about the birds and bats that may be injured by wind turbines. Some people believe wind turbines produce a lot of sound, and some think turbines affect their view of the landscape. On the other hand, wind is a clean, renewable energy source that produces no air pollution. And wind is free to use. Wind power is not the perfect answer to our electricity needs, but it is a valuable part of the solution.

### Power in a wind stream

A wind stream has total power given by  $P_t = \dot{m} \cdot (K.E.w) = 0.5 \dot{m} \cdot V_i^3$

Where,  $\dot{m}$  = mass flow rate of air, kg/s

$V_i$  = incoming wind velocity, m/s

Air mass flow rate is given by

$$\dot{m} = \rho A V_i$$

Where,  $\rho$  = Density of incoming wind,  $\text{kg/m}^3 = 1.226 \text{ kg/m}^3$  at 1 atm, 15°C

$A$  = Cross-sectional area of wind stream,  $\text{m}^2$

Substituting the above and accounting for the constants, we arrive at the following:

$$P_w = 0.5 \rho A V_i^3 C_p$$

Where,

$P_w$  = extracted power from the wind,

$\rho$  = air density. (approximately 1.2  $\text{kg/m}^3$  at 20°C at sea level)

$R$  = blade radius (in m). (it varies between 40-60 m)

$V_i$  = wind velocity (m/s) (velocity can be controlled between 3 to 30 m/s)

$C_p$  = the power coefficient which is a function of both tip speed ratio ( $\lambda$ ), and blade pitch angle,  $\beta$  (deg.)

Power coefficient ( $C_p$ ) is defined as the ratio of the output power produced to the power available in the wind.

### **Betz Limit**

Betz limit is the theoretical limit assigned to efficiency of a wind turbine. It states that no turbine can convert more than 59.3 % of wind kinetic energy into shaft mechanical energy. Thus the value of  $C$  is limited to Betz limit. For a well designed turbine the efficiency lies in the range of 35-45 %.

### **Wind Turbines**

A wind turbine is a rotating machine which converts the wind kinetic energy into mechanical energy. If the mechanical energy is then converted to electricity, the machine is called a wind generator, wind turbine. Wind turbines can be separated into two types based by the axis in which the turbine rotates as Horizontal Axis Wind Turbines and Vertical Axis Wind Turbines. The former are more commonly used due to several inherent advantages, the latter being used in small scale.



Wind Turbine Generator units

Turbine subsystems include:

- Rotors which convert wind energy into mechanical energy of the shaft ;
- Nacelle (enclosure) which contains all the conversion equipment, generator ,gear shaft etc.
- Tower, to increase the height of the turbine systems so that higher wind speeds are captured.
- Control equipment, Cables and other Civil works.



## **Horizontal Axis Wind Turbines (HAWTs)**

Horizontal-axis wind turbines (HAWT) get their name from the fact that their axis of rotation is horizontal. They have the main rotor shaft and electrical generator at the top of a tower, and are pointed into the wind. The variability of wind distribution and speed brings up the requirement of a gear system connected to the rotor and the generator. The gear system enables a constant speed of rotation to the generator thus enabling constant frequency generation. Turbine blades are made stiff in order to prevent the blades from being pushed into the tower by high winds. Downwind machines have also been built, as they no longer require a yaw mechanism to keep them facing the wind, and also because in high winds the blades can turn out of the wind thereby increasing drag and coming to a stop. Most of the HAWTs' are upwind as downwind systems cause regular turbulence which may lead to fatigue.

### **HAWT advantages**

- Variable blade pitch, which gives the turbine blades the optimum angle of attack.

Changing the angle of attack provides greater control over power generated and enables maximum efficiency.

- As wind energy increases with height, the tall tower in the HAWT gives access to higher windspeed. In some cases increase of even 10m height leads to increase in wind speed by 20 %
- In HAWTs' the blades move horizontally that is perpendicular to the wind and hence have minimum drag and they receive power throughout the rotation.



**HAWT disadvantages**

- Due to inherent large structures, construction costs are very high and so are transportation costs.
- Civil construction is costly due to erection of large towers.
- Wind turbine operation often leads to production of electronic noise which affects radar sites.
- In case of downwind HAWTs' the regular turbulence produced leads to structural failure.
- HAWTs require an additional yaw control mechanism to turn the blades toward the wind.

**Types of HAWTs:****Mono-Blade Horizontal Axis Wind Turbine (HAWT)****Features:**

1. They have lighter rotor and are cheaper.
2. Blade are 15-25 m long and are made up of metal, glass reinforced plastics, laminated wood, composite carbon fiber/ fiberglass etc.
3. Power generation is within the range 15 kW to 50 kW and service life of plant is 30 years.

**Advantages:**

1. Simple and lighter construction.
2. Favorable price

3. Easy to install and maintain.

**Disadvantages:**

1. Tethering control necessary for higher loads.
2. Not suitable for higher power ratings.

**Applications:**

1. Field irrigation
2. Sea-Water desalination Plants
3. Electric power supply for farms and remote loads.

**Twin-Blade HAWT**

1. They have large sizes and power output in range of 1 MW, 2 MW and 3MW.
2. These high power units feed directly to the distribution network.

**Blade HAWT**

1. 3 blade propeller type wind turbines have been installed in India as well as abroad.
  2. The rotor has three blades assembled on a hub. The blade tips have a pitch control of 0 to 30 degrees for controlling shaft speed.
  3. The shaft is mounted on bearings.
  4. The gear chain changes the speed from turbine shaft to generator shaft.
- Vertical axis Wind Turbines Vertical-axis wind turbines (or VAWTs) have the main rotor shaft arranged vertically as the plane of rotation is vertical. Blades are also vertical in this arrangement. The biggest advantage of VAWTs is they don't require a yaw control mechanism to be pointed into the wind.

These are useful in sites where wind direction is random or there is presence of large obstacles like trees, houses etc. Also VAWTs' don't require a tower structure and can be placed nearby a ground enabling access to electrical components. Some drawbacks are the low efficiency of wind production and the fact that large drag is created for rotating the blades in a vertical axis.

### **VAWT advantages**

- A massive tower structure is not required, as VAWTs' are mounted closer to the ground
- They don't require yaw mechanisms.
- These are located closer to the ground and hence easier to maintain.
- These have lower startup speeds than their horizontal counterparts. These can start at speeds as low as 10Kmph.
- These have a lower noise signature.

### **VAWT disadvantages**

- VAWTs' have lower efficiency as compared to HAWTs' because of the additional drag produced due to rotation of blades.
- Even though VAWTs' are located closer to the ground, the equipment now resides at the bottom of the turbines structure thus making it inaccessible.

- Because of their altitudes.

low height they cannot capture the wind energy stored in higher

### **Types of VAWTs**

#### **Persian Windmill:**

1. The Persian windmill was the earliest windmill installed. (7th Century A.D. – 13th Century A.D. in Persia, Afghanistan, and China)
2. It is a vertical axis windmill.. This windmill was used to grind grains and make flour.

#### **Savonius Rotor VAWT:**

1. Patented by S.J. Savonius in 1929.
2. It is used to measure wind current.
3. Efficiency is 31%.
4. It is Omni-directional and is therefore useful for places where wind changes direction frequently.

#### **Darrieus Rotor VAWT:**

1. It consists of 2 or 3 convex blades with airfoil cross-section.

2. The blades are mounted symmetrically on a vertical shaft.
3. To control speed of rotation mechanical brakes are incorporated. Those brakes consist of steel discs and spring applied air released calipers for each disc.

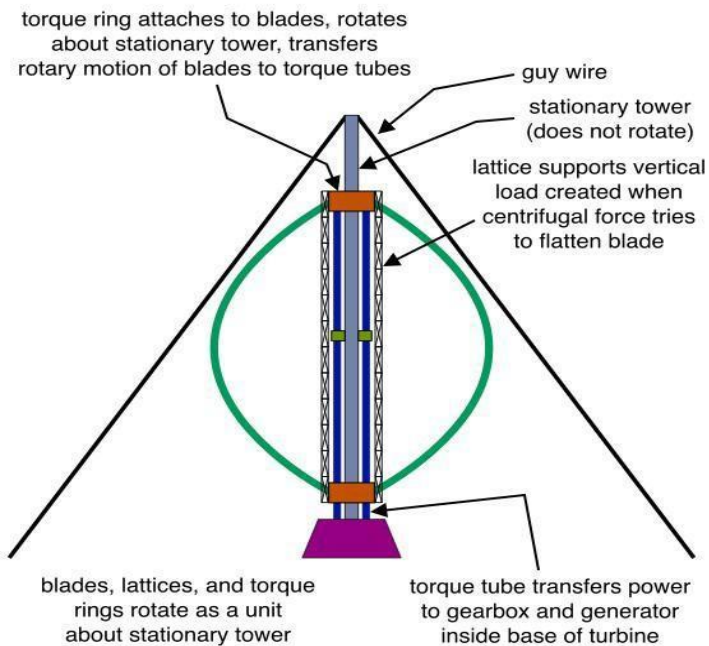

High Mechanical Efficiency Centrifugally Stable Darrieus Turbine

### Internal Components of a Wind Turbine

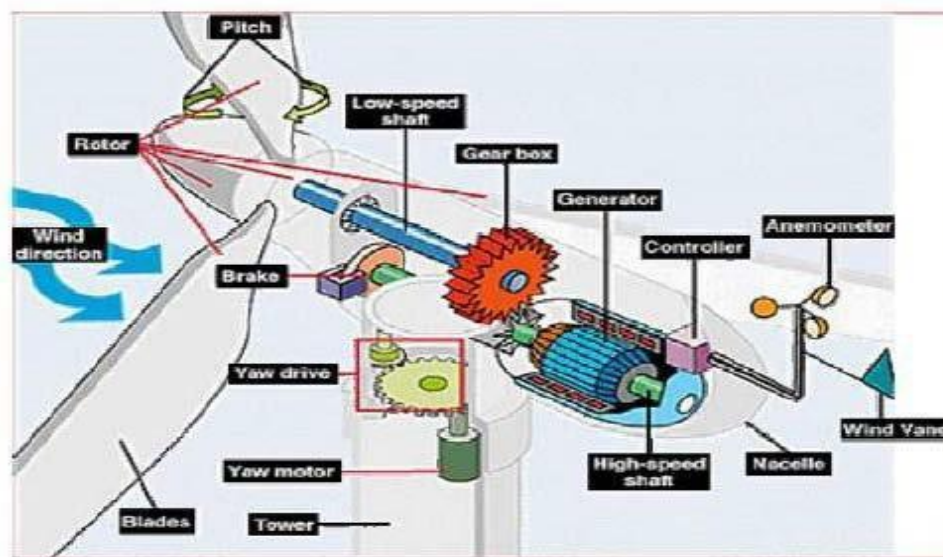



## Internal Components of a Wind Turbine

**Anemometer:** This device is used for measurement of speed. The wind speed is also fed to the controller as it is one of the variables for controlling pitch angle and yaw

**Blades:** These are aerodynamically designed structures such that when wind flows over them they are lifted as in airplane wings. The blades are also slightly turned for greater aerodynamic efficiency

**Brake:** This is either a mechanical, electrical or hydraulic brake used for stopping the turbine in high wind conditions

**Controller:** This is the most important part of the turbine as it controls everything from power output to pitch angle. The controller senses wind speed, wind direction, shaft speed and torque at one or more

**Gear box:** This steps-up or steps down the speed of turbine and with suitable coupling transmits rotating mechanical energy at a suitable speed to the generator. Typically a gear box system steps up rotation speed from 50 to 60 rpm to 1200 to 1500 rpm

**Generator:** This can be a synchronous or asynchronous AC machine producing power at 50Hz  
High-speed shaft: Its function is to drive the generator. Low-speed shaft: The rotor turns the low-speed shaft at about 30 to 60 rotations per minute.

**Nacelle:** The nacelle is the housing structure for high speed shaft, low speed shaft, gear box, generator, converter equipment etc. It is located at the top of the tower structure mostly in the shadow of the blades

**Pitch:** This is basically the angle the blades make with the wind. Changing the pitch angle changes whether the blades turn in or turn out of the wind stream.

**Rotor:** The hub and the blades together compose the rotor.

**Tower:** Towers are basically made up of tubular steel or steel lattice. Taller the towers

greater is the amount of power generated as the wind speed generally goes on increasing with height. Also the temp of generator and power output produced is sensed

**Wind direction:** Generally erratic in nature, hence the rotor is made to face into the wind by means of control systems.

**Wind vane:** Basically the job of a wind sensor, measuring the wind speed and communicating the same to the yaw drive, so as to turn the turbine into the wind flow direction.

**Yaw drive:** This drive controls the orientation of the blades towards the wind. In case the turbine is out of the wind, then the yaw drive rotates the turbine in the wind direction

**Yaw motor:** Powers the yaw drive.

## **DESIGN OF THE WIND TURBINE ROTOR**

There are several parameters involved in the design of an efficient yet economical wind turbine. Generally an efficient design of the blade is known to maximize the lift and minimize the drag on the blade. Now, minimization of the drag means that the aerofoil should face the relative wind in such a way that minimum possible area is exposed to the drag force of the wind. Furthermore the angle of this relative wind to the blades is determined by the relative magnitudes of the wind speed and the blade velocity. The thing to note here is that the wind velocity basically stays constant throughout the swept area but the blade velocity increases from the inner edge to the tip. Which means the relative angle of the wind with respect to the blade is ever-changing. Now the various parameters which determine the design of the wind turbine are noted below:

**Diameter of the Rotor:**

Since the power generated is directly proportional to the square of the diameter of the rotor, it becomes a valuable parameter. It's basically determined by the relation between the optimum power required to be generated and the mean wind speed of the area.

Power generated,

$$\begin{aligned}
 P &= \eta_e \eta_m C_p P_0 \\
 &= 1/2 \eta_e \eta_m C_p A \rho V_\infty^3 && \text{here, } \eta_e = \text{efficiency of electrical generation} \\
 &= 1/8 \eta_e \eta_m C_p \pi \rho V_\infty^3 D^2 && \eta_m = \text{efficiency of mechanical transmission}
 \end{aligned}$$

In the absence of concrete data, the following empirical formulae can be used:

$$\begin{aligned}
 P &= 0.15 V_\infty^3 D^2 && , \text{ for slow rotors} \\
 &= 0.20 V_\infty^3 D^2 && , \text{ for faster rotors}
 \end{aligned}$$

**Choice of the number of blades:**

The choice of the number of blades of a wind rotor is critical to its construction as well as operation. Greater number of blades is known to create turbulence in the system, and a lesser number wouldn't be capable enough to capture the optimum amount of wind energy. Hence the number of blades should be determined by both these constraints and after proper study of its dependence on the TSR. Now, let  $t$  be the time taken by one blade to move into the position previously occupied by the previous blade, so for an  $n$ -bladed rotor rotating at an angular velocity,  $\omega$  we have the following relation: Again let  $t_d$  be the time taken by the disturbed wind, generated by the interference of the blades to move away and normal air to be reestablished. Now this will basically depend on the wind

speed, on how fast or how slow the wind flow is. Hence it depends on the wind speed  $V$  & the length of the strongly perturbed wind stream, say  $d$ . Here we have:

$$t_b = d/V$$

For maximum power extraction,  $t_a$  &  $t_b$  should be equal, hence

$$t_a = t_b$$

$$\Rightarrow 2\pi/n\omega = d/V$$

$$\Rightarrow d = 2\pi V/n\omega$$

$d$  has to be determined empirically.

### Power Speed Characteristics

The mechanical power that can be extracted from the wind depends heavily on the wind speed, and for each wind speed there is always an optimum turbine speed at which the wind power extracted at the shaft of the turbine is maximum, at any other speed apart from this optimum speed we get sub-standard operation of the system. So our chief goal would be to find out the optimum turbine speed over the operational range of the wind stream speeds. This thing is basically area specific, because the wind speeds would vary from place to place. Now the mechanical power transmitted at the shaft is:

$$P = 0.5 C_p A \rho V_\infty^3$$

As we know  $C_p$  is a function of the TSR & the pitch angle. For a wind turbine with radius  $R$ , the above formula can be written as,

$$P=0.5C_p \pi R^2 \rho V_\infty^3$$

Now as the TSR,  $\lambda = \omega R / V_\infty$

The maximum value of the shaft power output for any wind speed can be expressed as:

$$P_m = 0.5 C_p \pi (R^5 / \lambda^3) \omega^3 \rho$$

$$\Rightarrow P_m \propto \omega^3$$

## **Indian Wind Energy Potential**

### **Indian Scenar**

India has a vast supply of renewable energy resources. India has one of the world's largest. Programs for deployment of renewable energy products and systems, with wind energy being one of the highest with 11087MW installed.

The Indian wind energy scene is upbeat, with a large number of forays being made by multinationals like vestas, gamesa, GE power etc. and with suzlon making brisk pace in the international market, the nations wind potential is rightly being tapped. Here we analyze the wind potential of four distinct spots on the subcontinent.

### **Advantages of Wind Power**

The wind blows day and night, which allows windmills to produce electricity throughout the day. (Faster during the day) Energy output from a wind turbine will vary as the wind varies, although the most rapid variations will to some extent be compensated for by the inertia of the wind turbine rotor. Wind energy is a domestic, renewable source of energy that generates no pollution and has little environmental impact. Up to 95 percent of land used for wind farms can also be used for other profitable activities including ranching, farming and forestry.

The decreasing cost of wind power and the growing interest in renewable energy sources should ensure that wind power will become a viable energy source in the United States and worldwide.

### **isadvantages of wind power**

Intermittent output of wind energy

Low energy density of wind energy

Wildlife

Aesthetics

National Security

1. Wind energy available is dilute and fluctuating in nature.
2. Noisy in operation
3. Large area is required
4. Wind velocity in India are relatively low (5 km/hr to 20 km/hr)

### **SITE SELECTION CONSIDERATIONS:**

This is a list of things to consider when selecting sites for installing wind monitoring devices and wind generators. Site selection will depend on a number of factors including the general terrain and wind flow characteristics of an area and the proximity to the location of intended use. For more detailed information, check the references listed below.

**Considerations:**

**Wind Characteristics:** Ideal sites are generally located in areas with good exposure to the prevailing wind, away from structures, terrain or vegetation that might alter the wind or introduce excessive turbulence. For wind measurement, sites that represent a wide area are ideal in order to estimate the wind resource over as wide an area as possible. Vegetation will often show signs of "flagging" if wind is present in sufficient amounts.

**Proximity to End Use:** The costs associated with wind energy grow with increased distance to where the energy might be used. A windy site close to transmission lines or close to a pumping location might be most appropriate.

**Terrain and Land Use:** Consider the amount of land available, how this land is currently used, it's proximity to other uses such as roads, houses, towns or parks. Avoid potential problems by considering your neighbors and the public in this process.

**Site Accessibility:** To install a monitoring tower or a wind turbine and to provide routine maintenance it will be necessary to get equipment to the site. Accessibility may be important. It may also be useful to have cell phone coverage at the site to obtain help with maintenance issues that might arise.

The following characteristics are important in considering a wind turbine site, and are examined in this

- A. Predicted Wind Resource
- B. Noise
- C. Environmental Issues and Permitting
- D. Proximity to Airports



E. Wind Turbine Component Transportation & Access

F. Distance to Transmission/Distribution Lines for Power Distribution

G. Net-metering

H. Production Estimates for Selected Turbines

**Some wind mills located in India**

1. Cazri wind mills at jodhapur
2. WP-2 water pumping wind mill by NAL, Bangalore
3. Madurai wind mill
4. Jayabji wind mill in rajasthan etc.

## Module -4

# BIOMASS ENERGY

Biomass is biological material from living, or recently living organisms, most often referring to plants or plant-derived materials. As a renewable energy source, biomass can either be used directly, or indirectly -- once or converted into another type of energy product such as biofuel. Biomass can be converted to energy in three ways: thermal conversion, chemical conversion, and biochemical conversion.

Historically, humans have harnessed biomass derived energy products since the time when people began burning wood to make fire. In modern times, the term can be referred to in two meanings. In the first sense, biomass is plant matter used either to generate electricity (via steam turbines or gasifiers), or to produce heat (via direct combustion). Wood remains the largest biomass energy source today; examples include forest residues (such as dead trees, branches and tree stumps), yard clippings, wood chips and even municipal solid waste. In the second sense, biomass includes plant or animal matter that can be converted into fibers or other industrial chemicals, including biofuels. Industrial biomass can be grown from numerous types of plants, including miscanthus, switchgrass, hemp, corn, poplar, willow, sorghum, sugarcane, bamboo, and a variety of tree species, ranging from eucalyptus to oil palm (palm oil).

The adoption of biomass-based energy plants has been a slow but steady process. Over the past decade, the production of these plants has increased 14%. In the United States, alternative electricity-production sources on the whole generate about 13% of power; of this fraction, biomass contributes approximately 11% of the alternative production. According to a study conducted in early 2012, of the 107 operating biomass plants in the United States, 85 have been cited by federal or state regulators for the violation of clean air or water standards laws over the past 5 years. This data also includes minor infractions.

Biomass mass derived energy also holds the promise of reducing carbon dioxide emissions, a significant contributor to global warming, carbon dioxide acts as a “greenhouse” gas by trapping heat absorbed by the earth from the sun. Although the burning of biomass energy releases as much carbon dioxide as fossil fuels, biomass burning does not release “new carbon” into the

atmosphere while burning fossil fuels does.

This is because carbon dioxide released from fossil fuels was carbon that was fixated via photosynthesis millions of years ago that had been locked in the hydrocarbons of fossil fuels.

Industry professionals claim that a range of issues can affect a plant's ability to comply with emissions standards. Some of these challenges, unique to biomass plants, include inconsistent fuel supplies and age. The type and amount of the fuel supply is completely reliant factors; the fuel can be in the form of building debris or agricultural waste (such as deforestation of invasive species or orchard trimmings). Furthermore, many of the biomass plants are old, use outdated technology and were not built to comply with today's stringent standards. In fact, many are based on technologies developed during the term of President Jimmy Carter, who created the Department of Energy in 1977.

The Energy Information Administration projected that by 2017, biomass is expected to be about twice as expensive as natural gas, slightly more expensive than nuclear power, and much less expensive than solar panels. In another EIA study released, concerning the government's plan to implement a 25% renewable energy standard by 2025, the agency assumed that 598 million tons of biomass would be available, accounting for 12% of the renewable energy in the plan

### **PRINCIPLES FOR PRODUCTION OF BIOGAS:**

Organic substances exist in wide variety from living beings to dead organisms . Organic matters are composed of Carbon (C), combined with elements such as Hydrogen (H), Oxygen (O), Nitrogen (N), Sulphur (S) to form variety of organic compounds such as carbohydrates, proteins & lipids. In nature MOs (microorganisms), through digestion process breaks the complex carbon into smaller substances.

**There are 2 types of digestion process :**

Aerobic digestion.

Anaerobic digestion.15



The digestion process occurring in presence of Oxygen is called Aerobic digestion and produces mixtures of gases having carbon dioxide (CO<sub>2</sub>), one of the main “green houses” responsible for global warming.

The digestion process occurring without (absence) oxygen is called Anaerobic digestion which generates mixtures of gases. The gas produced which is mainly methane produces 5200-5800 KJ/m<sup>3</sup> which when burned at normal room temperature and presents a viable environmentally friendly energy source to replace fossil fuels (non-renewable

### **OBJECTIVES:**

Optimization of gas production

Comparison with conventional plants

Effect of different parameters viz.

- \* Temperature
- \* PH
- \* Total & volatile solid concentration
- \* Alkalinity
- \* C:N Ratio

To increase the production by using \*

- \* Additives
- \* Nutrients
- \* Nitrogen source

### **Photosynthesis:**

Photosynthesis is the process of converting light energy to chemical energy and storing it in the bonds of sugar. This process occurs in plants and some algae (Kingdom Protista). Plants need only light energy, CO<sub>2</sub>, and H<sub>2</sub>O to make sugar. The process of photosynthesis takes place in the chloroplasts, specifically using chlorophyll, the green pigment involved in photosynthesis.

Photosynthesis takes place primarily in plant leaves, and little to none occurs in stems, etc. The parts of a typical leaf include the upper and lower epidermis, the mesophyll, the vascular bundle(s) (veins), and the stomates. The upper and lower epidermal cells do not have chloroplasts, thus photosynthesis does not occur there. They serve primarily as protection for the rest of the leaf. The stomates are holes which occur primarily in the lower epidermis and are for air exchange: they let CO<sub>2</sub> in and O<sub>2</sub> out. The vascular bundles or veins in a leaf are part of the plant's transportation system, moving water and nutrients around the plant as needed. The mesophyll cells have chloroplasts and this is where photosynthesis occurs.

As you hopefully recall, the parts of a chloroplast include the outer and inner membranes, intermembrane space, stroma, and thylakoids stacked in grana. The chlorophyll is built into the membranes of the thylakoids.

Chlorophyll looks green because it absorbs red and blue light, making these colors unavailable to be seen by our eyes. It is the green light which is NOT absorbed that finally reaches our eyes, making chlorophyll appear green. However, it is the energy from the red and blue light that are absorbed that is, thereby, able to be used to do photosynthesis. The green light we can see is not/cannot be absorbed by the plant, and thus cannot be used to do photosynthesis.

The overall chemical reaction involved in photosynthesis is:  $6\text{CO}_2 + 6\text{H}_2\text{O} (+ \text{light energy}) \rightarrow \text{C}_6\text{H}_{12}\text{O}_6 + 6\text{O}_2$ . This is the source of the O<sub>2</sub> we breathe, and thus, a significant factor in the concerns about deforestation.

### **Stages of Photosynthesis:**

Photosynthesis is a two stage process. The first process is the Light Dependent Process (Light Reactions), requires the direct energy of light to make energy carrier molecules that are used in the second process. The Light Independent Process (or Dark Reactions) occurs when the products of the Light Reaction are used to form C-C covalent bonds of carbohydrates. The Dark Reactions can usually occur in the dark, if the energy carriers from the light process are present. Recent evidence suggests that a major enzyme of the Dark Reaction is indirectly stimulated by light, thus the term Dark Reaction is somewhat of a misnomer. The Light Reactions occur in the grana and the Dark Reactions take place in the stroma of the chloroplasts.

**Biofuel:**

A biofuel is a type of fuel whose energy is derived from biological carbon fixation. Biofuels include fuels derived from biomass conversion, as well as solid biomass, liquid fuels and various biogases. Biofuels are gaining increased public and scientific attention, driven by factors such as oil price hikes and the need for increased energy security. However, according to the European Environment Agency, biofuels do not address global warming concerns.

Bioethanol is an alcohol made by fermentation, mostly from carbohydrates produced in sugar or starch crops such as corn or sugarcane. Cellulosic biomass, derived from non-food sources, such as trees and grasses, is also being developed as a feedstock for ethanol production. Ethanol can be used as a fuel for vehicles in its pure form, but it is usually used as a gasoline additive to increase octane and improve vehicle emissions. Bioethanol is widely used in the USA and in Brazil. Current plant design does not provide for converting the lignin portion of plant raw materials to fuel components by fermentation.

Biodiesel is made from vegetable oils and animal fats. Biodiesel can be used as a fuel for vehicles in its pure form, but it is usually used as a diesel additive to reduce levels of particulates, carbon monoxide, and hydrocarbons from diesel-powered vehicles. Biodiesel is produced from oils or fats using transesterification and is the most common biofuel in Europe.

In 2010, worldwide biofuel production reached 105 billion liters (28 billion gallons US), up 17% from 2009, and biofuels provided 2.7% of the world's fuels for road transport, a contribution largely made up of ethanol and biodiesel.[citation needed] Global ethanol fuel production reached 86 billion liters (23 billion gallons US) in 2010, with the United States and Brazil as the world's top producers, accounting together for 90% of global production. The world's largest biodiesel producer is the European Union, accounting for 53% of all biodiesel production in 2010.[3] As of 2011, mandates for blending biofuels exist in 31 countries at the national level and in 29 states or provinces. According to the International Energy Agency, biofuels have the potential to meet more than a quarter of world demand for transportation fuels by 2050.

**Bioalcohols:**

Biologically produced alcohols, most commonly ethanol, and less commonly propanol and butanol, are produced by the action of microorganisms and enzymes through the fermentation of sugars or starches (easiest), or cellulose (which is more difficult). Biobutanol (also called biogasoline) is often claimed to provide a direct replacement for gasoline, because it can be used directly in a gasoline engine (in a similar way to biodiesel in diesel engines).

Ethanol fuel is the most common biofuel worldwide, particularly in Brazil. Alcohol fuels are produced by fermentation of sugars derived from wheat, corn, sugar beets, sugar cane, molasses and any sugar or starch from which alcoholic beverages can be made (such as potato and fruit waste, etc.). The ethanol production methods used are enzyme digestion (to release sugars from stored starches), fermentation of the sugars, distillation and drying. The distillation process requires significant energy input for heat (often unsustainable natural gas fossil fuel, but cellulosic biomass such as bagasse, the waste left after sugar cane is pressed to extract its juice, can also be used more sustainably).

Ethanol can be used in petrol engines as a replacement for gasoline; it can be mixed with gasoline to any percentage. Most existing car petrol engines can run on blends of up to 15% bioethanol with petroleum/gasoline. Ethanol has a smaller energy density than that of gasoline; this means it takes more fuel (volume and mass) to produce the same amount of work. An advantage of ethanol ( $\text{CH}_3\text{CH}_2\text{OH}$ ) is that it has a higher octane rating than ethanol-free gasoline available at roadside gas stations, which allows an increase of an engine's compression ratio for increased thermal efficiency. In high-altitude (thin air) locations, some states mandate a mix of gasoline and ethanol as a winter oxidizer to reduce atmospheric pollution emissions.

Ethanol is also used to fuel bioethanol fireplaces. As they do not require a chimney and are "flueless", bioethanol fires are extremely useful for newly built homes and apartments without a flue. The downside to these fireplaces is their heat output is slightly less than electric heat or gas fires.

In the current corn-to-ethanol production model in the United States, considering the total energy consumed by farm equipment, cultivation, planting, fertilizers, pesticides, herbicides, and



fungicides made from petroleum, irrigation systems, harvesting, transport of feedstock to processing plants, fermentation, distillation, drying, transport to fuel terminals and retail pumps, and lower ethanol fuel energy content, the net energy content value added and delivered to consumers is very small. And, the net benefit (all things considered) does little to reduce imported oil and fossil fuels required to produce the ethanol.

Although corn-to-ethanol and other food stocks have implications both in terms of world food prices and limited, yet positive, energy yield (in terms of energy delivered to customer/fossil fuels used), the technology has led to the development of cellulosic ethanol. According to a joint research agenda conducted through the US Department of Energy,[8] the fossil energy ratios (FER) for cellulosic ethanol, corn ethanol, and gasoline are 10.3, 1.36, and 0.81, respectively.

Even dry ethanol has roughly one-third lower energy content per unit of volume compared to gasoline, so larger (therefore heavier) fuel tanks are required to travel the same distance, or more fuel stops are required. With large current unsustainable, unscalable subsidies, ethanol fuel still costs much more per distance traveled than current high gasoline prices in the United States.

Methanol is currently produced from natural gas, a nonrenewable fossil fuel. It can also be produced from biomass as biomethanol. The methanol economy is an alternative to the hydrogen economy, compared to today's hydrogen production from natural gas.

Butanol (C<sub>4</sub>H<sub>9</sub>OH) is formed by ABE fermentation (acetone, butanol, ethanol) and experimental modifications of the process show potentially high net energy gains with butanol as the only liquid product. Butanol will produce more energy and allegedly can be burned "straight" in existing gasoline engines (without modification to the engine or car), and is less corrosive and less water-soluble than ethanol, and could be distributed via existing infrastructures. DuPont and BP are working together to help develop butanol. E. coli strains have also been successfully engineered to produce butanol by hijacking their amino acid metabolism.

### **Biogas:**

Biogas is methane produced by the process of anaerobic digestion of organic material by

anaerobes. It can be produced either from biodegradable waste materials or by the use of energy crops fed into anaerobic digesters to supplement gas yields. The solid byproduct, digestate, can be used as a biofuel or a fertilizer.

Biogas can be recovered from mechanical biological treatment waste processing systems.

Note: Landfill gas, a less clean form of biogas, is produced in landfills through naturally occurring anaerobic digestion. If it escapes into the atmosphere, it is a potential greenhouse gas.

Farmers can produce biogas from manure from their cattle by using anaerobic digesters

**Factors affecting Biogas production:**

1. Substrate temperature
2. pH level
3. Mixing Ratio
4. Loading Rate
5. Hydraulic Retention time
6. Nitrogen inhibition
7. C/N ratio
8. Agitation
9. Toxicity
10. Solid concentration
11. Seeding
12. Metal Cations
13. Particle size
14. Additives
15. BOD

16. COD

17. Heating

### **BENEFITS OF BIOGAS TECHNOLOGY :**

Production of energy.

Transformation of organic wastes to very high quality fertilizer.

Improvement of hygienic conditions through reduction of pathogens.

Environmental advantages through protection of soil, water, air etc. Micro-economical benefits by energy and fertilizer substitutes. Macro-economical benefits through decentralizes energy generation and environmental protection.

### **Main types of simple biogas plants :**

- balloon plants,

- fixed-dome plants,

- floating-drum plants.

#### **Balloon Plants:**

A balloon plant consists of a plastic or rubber digester bag, in the upper part of which the gas is stored. The inlet and outlet are attached direct to the skin of the balloon. When the gas space is full, the plant works like a fixed-dome plant - i.e., the balloon is not inflated; it is not very elastic. The fermentation slurry is agitated slightly by the movement of the balloon skin. This is favourable to the digestion process. Even difficult feed materials, such as water hyacinths, can be used in a balloon plant. The balloon material must be UV-resistant. Materials which have been used successfully include RMP (red mud plastic), Trevira and butyl.

**Advantages:**

Low cost, ease of transportation, low construction (important if the water table is high), high digester temperatures, uncomplicated cleaning, emptying and maintenance.

**Disadvantages:**

Short life (about five years), easily damaged, does not create employment locally, little scope for self-help.

Balloon plants can be recommended wherever the balloon skin is not likely to be damaged and where the temperature is even and high. One variant of the balloon plant is the channel-type digester with foil and sunshade.

**Fixed-Dome Plants:**

A fixed-dome plant consists of an enclosed digester with a fixed, non-movable gas space. The gas is stored in the upper part of the digester. When gas production commences, the slurry is displaced into the compensating tank. Gas pressure increases with the volume of gas stored; therefore the volume of the digester should not exceed 20 m<sup>3</sup>. If there is little gas in the holder, the gas pressure is low.

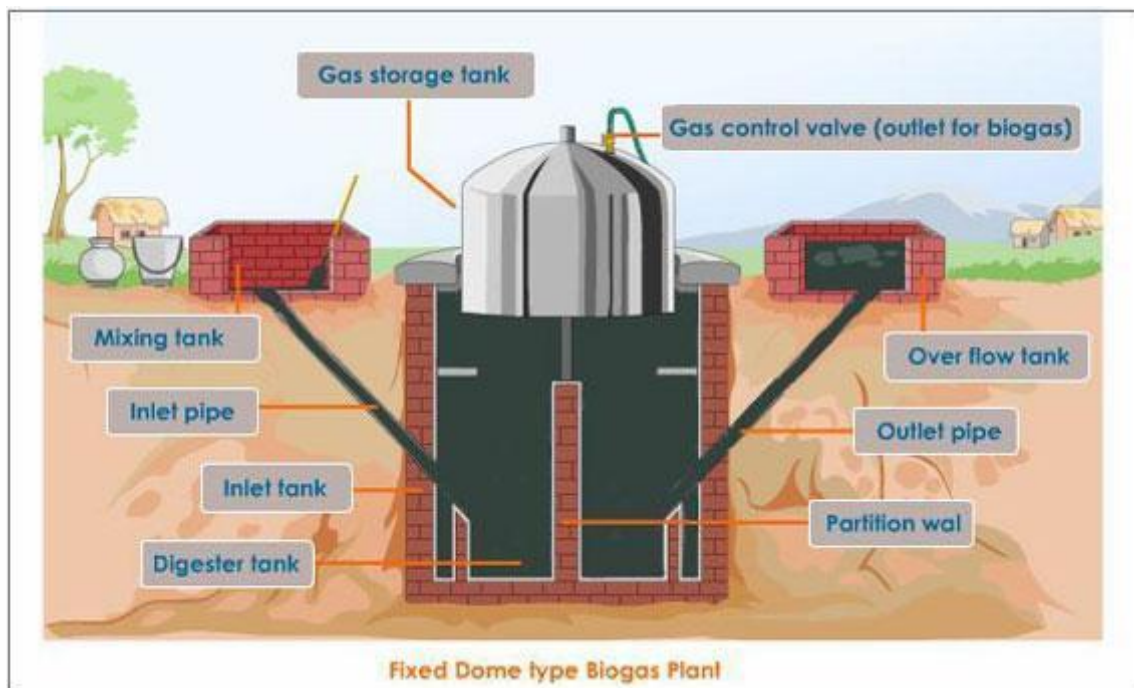

**Floating-Drum Plants:**

Floating-drum plants consist of a digester and a moving gasholder. The gasholder floats either directly on the fermentation slurry or in a water jacket of its own. The gas collects in the gas drum, which thereby rises. If gas is drawn off, it falls again. The gas drum is prevented from tilting by a guide frame.

**Advantages:**

Simple, easily understood operation, constant gas pressure, volume of stored gas visible directly, few mistakes in construction.

**Disadvantages:**

High construction cost of floating-drum, many steel parts liable to corrosion, resulting in short life (up to 15 years; in tropical coastal regions about five years for the drum), regular maintenance costs due to painting.

In spite of these disadvantages, floating-drum plants are always to be recommended in cases of doubt. Water-jacket plants are universally applicable and especially easy to maintain. The drum won't stick, even if the substrate has a high solids content.

Floating-drums made of glass-fibre reinforced plastic and high density polyethylene have been used successfully, but the construction cost is higher than with steel. Floating-drums made of wire-mesh-reinforced concrete are liable to hairline cracking and are intrinsically porous. They require a gaslight, elastic internal coating. PVC drums are unsuitable because not resistant to UV.

The floating gas drum can be replaced by a balloon above the digester. This reduces construction costs (channel type digester with folia), but in practice problems always arise with the attachment of the balloon at the edge. Such plants are still being tested under practical conditions.

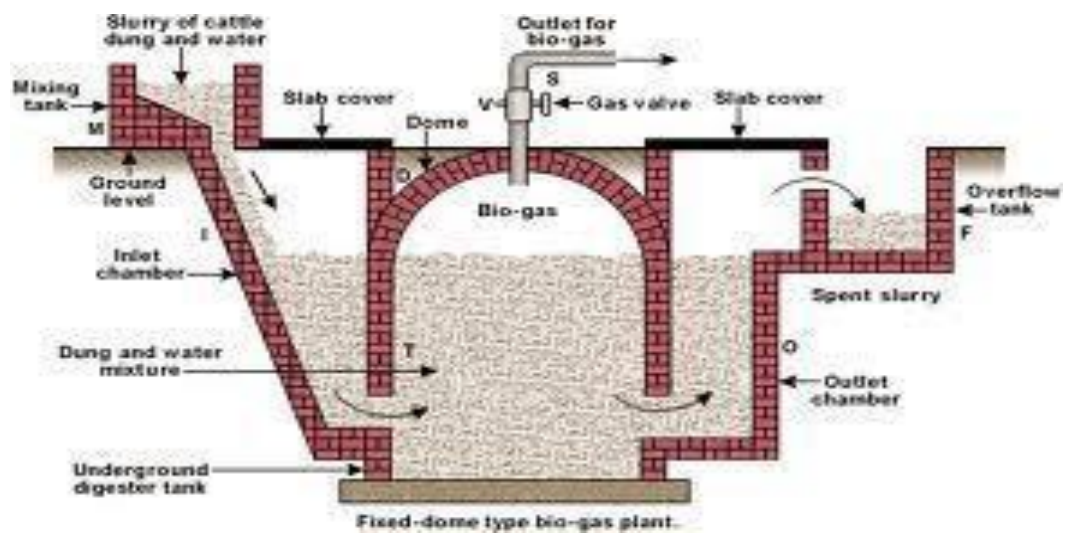



**Energy from biomass:**

1. Alternative source of energy
2. We have plenty of agricultural and forests for production of biomass.
3. Produced through photosynthesis achieved by solar energy conversion
4. Biomass means organic matter (Carbohydrate)
5.  $H_2O + CO_2 \text{ -----} > CH_2O + O_2$
6.  $CH_2O + O_2 \text{ -----} > CO_2 + H_2O + 112 \text{ Kcal/mole}$
7. Algae has lots of carbohydrates, could be harvested, dried and burned for production of heat 8.that could be converted into electricity.
9. Can be converted into liquid and gaseous fuels.

**Advantage and applications:**

- In big cities, sewage source is the main source for production of biogas.
- The sewage biogas is found to contain 84% methane, could be economically used to run engines to drive electric generator.
- In the rural sector, cooking and lighting mechanical power for generation of small electricity.
- The gas can be used with advantage to improve sanitary conditions and also to check environmental pollutions.
- 12 lakhs families in india are installed bio gas plants.
- Maradnagar (U.P.), Rishikesh (U.P.), Sanganer (Raj), Sihar (Raj) Pondicheri, bhopal etc.,

**ENERGY FROM THE OCEANS**

Tide energy can furnish a significant portion of all such energies which are renewable in

nature. It has been estimated that about a billion kW of tidal power is dissipated by friction and eddies alone. This is slightly less than the economically exploitable power potential of all the rivers of the World. It is only indication of the magnitude of tidal power available; all of it is not economically feasible also. The first attempt to utilize energy of the ocean was in the form of tidal “mills “in the eleventh century in Great Britain and latter in France and Spain. The large scale up and down movement of sea water represents an unlimited source of energy. If some part of this vast energy can be converted into electrical energy it would be an important source of hydro-power. The main feature of the tidal cycle is the difference in water surface elevations at the high tide and at the low tide. If this differential head could be utilized in operating a hydraulic turbine, the tidal energy could be converted into electrical energy by means of an attached generator.

**In principle**, this is not very difficult as water, at the time of high tide, is at a high level and can be let into a basin to be stored at a high level. The same water can be let back into the sea during the low tide through the turbines, thus producing power.

Since the basin water level is high and sea water is low, there is a differential head comparable to the tidal range that can be utilized for the running of the turbines. Basically it appears to be a simple proposition, the problems involved in it, are many.

The Tides, as we see, although free, were inconvenient because they come at varying times from day to day, have varying ranges (heads) and, for large outputs required large capital expenditures.

Their early use declined and eventually came to a halt with the coming of the age of steam and cheap coal. With the beginning of the energy crisis in the 1970s, the tidal energy, like other renewable energy sources, received renewed attention.

The first tidal power plant was commissioned by General DeGaulle at La Rance in 1966 which marked a breakthrough. The average tidal range is 8.4 m ( $\pm 4.2$  m), and the maximum is 13.5 m.

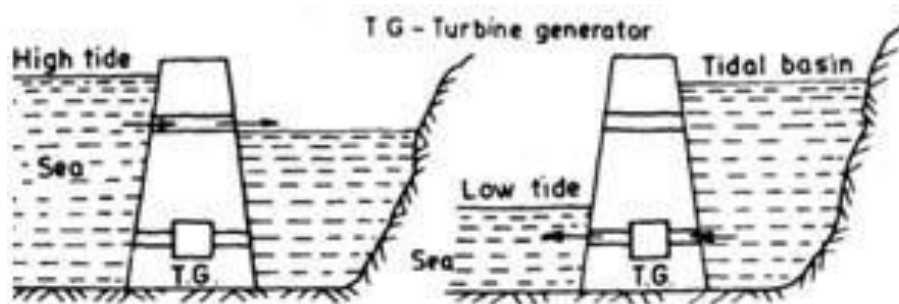

**Fig.PRINCIPLE OF TIDAL POWER GENERATION.**

Effective basin surface is 22 km<sup>2</sup> ; basin volume is 184,000,000 m<sup>3</sup>. There are no special problems with this site, and it was a very sensible choice for the world's *first* tidal power station.

It has used a single basin and submerged reversible propeller type turbine generators that could generate power with the water flowing in either direction through the turbine runner.

Bulb turbines have been provided in this project, they are operating satisfactorily for the last 25 years.

The dam contains a small lock for commercial vessels, six movable sluice gates, and 24 turbo generators units of 10 MW each. The movable gates are used to accelerate filling and emptying of the storage basin at small differential water levels.

Installed capacity of 240 MW, but of course the average power generating capacity is less, because power can be generated only intermittently.

Maximum electric energy production capacity is 544,000 MW h/yr., which gives a plant capacity factor, without any allowance for maintenance or down time, of 0.26.

Maximum utilization of the stored hydraulic potential energy is 18 per cent, which may be increased to 24% in future by additional of 80 MW more generating capacity.

There are presently two tidal power stations operating, one in France and one in the USSR. The one in France is a full commercial station. The one in the USSR is more in the nature of a pilot plant engineering experiment, and is rather small in size.

The French project at Rance near St. Malo in Brittany, uses a dam that goes straight across the estuary of the Rance river. The dam is not too long—750 m, shore to shore. The depth is never more than 12 m below mean sea level, there is an above surface rock part way across, the climate is moderate, KisloyaGuba, on the Barents sea, 70km north of Murmansk.

It is small and was intended as a pilot project. It has one generator of 400 MW rating and delivers 700 to 800 MWh/yr, to the local electrical grid operation began in 1968.

Nearly for 17 years there was a dull period in the tidal power development due to the problems involved in it. The main disadvantage of tidal power plant is that the production of power from tidal station occurs at times and in magnitudes which are dependent on the relative positions of earth, moon and sun to one another and not on the electrical demand of consumers.

The success of La Rance stimulated interest in Canada where on the eastern coast, in the Bay of Fundy, the largest tidal ranges in the World occur—being as high as 16 m—on spring tides. The pioneering project in Nova Scotia, Canada at Annapolis Royal was commissioned in 1983. For the first time conventional bulb turbines were replaced by large rim generator units of straflo turbines with runner diameter of 7.6 m and capacity of 10 MW.

Though this type of turbine has been in use for many years in Europe, its runner diameter was limited to about 2 m by sealing problems at the runner periphery.

If these prove successful, it will provide an attractive alternative to the bulb unit, since the straflo unit has much higher inertia, thus enhancing system stability, and access to the generator is easier, thus facilitating maintenance.

**In India**, there are possible tidal projects in the Gulf of Kutch and Cambay, and on a smaller scale, in the Sunderbans regions of the Bay of Bengal.

**In Korea**, there have been a series of studies by Canadian and French firms, the latest one being of Garolim **Bay**. **A comparative** statistics of some recently proposed tidal schemes are given in the **table**.

**Table : Comparative Statistics of some Recently Proposed Schemes**

| Country Site                             | Installed capacity (MW) | Actual energy (GW h) | No. of 7.6 m diameter turbines | range (m) |
|--|-------------------------|----------------------|--------------------------------|-----------|
| UK Seven Estuary                         | 7200                    | 13000                | 230                            | 9.3       |
|  | 525                     | 1090                 | 21                             | 6.7       |
| Mersy Estuary                            | 210                     | 530                  | 30                             | 3.1       |
| Strangford Lough Eire<br>Shannon Estuary | 318                     | 715                  | 30                             | 3.8       |

|                             |     |      |    |     |
|-----------------------------|-----|------|----|-----|
| India Gulf of Kutch: Kandla | 600 | 1600 | 43 | 5.2 |
| Korea Garolim Bay           | 480 | 1200 | 32 | 4.6 |
| Brazil Bacanga              | 30  | 55   | 2  | 4.1 |

|                         |       |       |          |      |
|-------------------------|-------|-------|----------|------|
| U.S.A. Knoik Arm        | 2220  | 5500  | 80       | 7.8  |
| Canada Cumberland basin | 1147  | 3420  | 37       | 10.5 |
| Cobequid Bay            |       | 12600 | 106      | 12.4 |
| Annapolis Royal         | 20    | 50    | 1        | 6.7  |
| China Liangxia          | 3     | 11    | 6(2.5 m) | .- 6 |
| USSR Lumbousky          | 400   | —     | —        | -6   |
| Mezenskaya              | 10000 | —     | —        | — 9  |

## BASIC PRINCIPAL OF TIDAL POWER

Tides are produced mainly by the gravitational attraction of the moon and the sun on the water of solid earth and the oceans. About 70 per cent of the tide producing force is due to the moon and 30 per cent to the sun. The moon is thus the major factor in the tide formation.

Surface water is pulled away from the earth on the side facing the moon, and at the same time the solid earth is pulled away from the water on the opposite side. Thus high tides occur in these two areas with low tides at intermediate points. As the earth rotates, the position of a given area relative to the moon changes, and so also do the tides.

There is thus a periodic succession of high and low tides. Although there are exceptions, two tidal cycles (*i.e.* two high tides and two low tides) occur during a lunar day of 24 hours and 50 minutes (The lunar day is the apparent time of revolution of the moon about the earth).

That is to say, the time between high tides and low tide at any given location is a little over 6 hours. A high tide will be experienced at a point which is directly under the moon. At the same time, a diametrically opposite point on the earth's surface also experiences a high tide due to dynamic balancing.

Thus a full moon as well as a no moon produce a high tide. In a period of 24 hrs 50 minutes, there are therefore, two high tides and two low tides. Fig. These are called semi-diurnal tides. The rise and fall of the water level follows a sinusoidal curve, shown with point A indicating the high tide point and point B indicating the low tide point. The average time for the water level to fall from A to B and then rise to C is approximately 6 hours 12.5 mm.



The difference between high and low water levels is called the *range* of the tide. The *tidal range* R is defined as:

$R = \text{water elevation at high tide} - \text{water elevation at low tide}.$

Because of the changing positions of the moon and sun relative to the earth, the range varies continuously. There are however, some characteristic features of this variation.

At times near full or new moon, when sun, moon and earth are approximately in a line, the gravitational forces of sun and moon enhance each other. The tidal range is then exceptionally large, the high tides are higher and low tides are lower than the average. These high tides are called *spring tides*, on the other hand, near the first and third quarters of the moon, when the sun and moon are at right angles with respect to the earth, *neap tides* occur. The tidal range is then exceptionally small; the high tides are lower and the low tides higher than the average. Hence the range is not constant.

It varies during the 29.5 day lunar month (Fig.) being maximum at the time of new and full moons, called the spring tides, and minimum at the time of the first and third quarter moons, called the neap tides. The spring-neap tidal cycle lasts one-half of a lunar month. A typical *mean range* is roughly one third of the spring range. The actual variations in range are somewhat complicated by seasonal variations caused by the ellipticity of the earth's orbit around the sun.

The variations in the periodicity and monthly and seasonal ranges must, of course, be taken into account in the design and operation of tidal power plants. The tides, however, are usually predictable, and fairly accurate tide tables are usually available.

**Spring  
tide**      **Neap  
tide**      **Spring  
tide**      **Neap  
tide**      **Spring  
tide**

**Fig. Relative high and low tides showing variation in range during lunar month.**

Tidal ranges vary from one earth location to another. They are influenced by such conditions as the profile of the local shoreline and water depth. When these are favourable, a resonance like effect causes very large tidal ranges. Ranges have to be very large to justify the huge costs of building dams and associated hydroelectric power plants. Such tides occur only in a few locations in the world.

**Following *points* have to be specially noted in connection with the tidal phenomenon.**

(1) The tides are a periodical phenomenon but no two tides in any cycle are alike. Since the relative positions of sun and moon and their distances from earth are continuously changing, the tides are also influenced accordingly.

Of the two high tides in a single day, one tide is higher than the other. In any month, the tides on the full moon and no moon days are particularly higher than the rest, as on these days sun's and moon's attraction acts in a directly additive manner. These are termed as the spring tides.

In any year, the tides that occur at the time of vernal and autumnal equinoxes will be even higher due to the relative location of the sun and earth. Thus the tidal range  $R$  shown in the figure varies from time to time. Generally, a long time mean value of  $R$  is designated as mean tidal range at any particular place.

(2) The mean tidal range varies from place to place. The shape of the tidal cycle depends upon the interaction of the sea with the coast-line. Where the coast-line offers a resonating influence,

the tidal range gets accentuated, at the other places, the land may produce a dampening effect on the tidal phenomenon. For instance, in land locked seas, the tidal phenomenon is always much subdued. Because of this interacting effect, the tidal range (as well as the tidal period) varies from place to place. For example; the mean tidal range on the west coast of India is as high as 7

to 8 meters near the gulf of Kutch, whereas it is only one meter or so near Kerala, down south. Bay of Fundy (Canada) has one of the greatest tidal ranges in the world *i.e.* of 20 m, whereas the Adriatic sea at the Zara has virtually static water with the range being only of a few cm. Thus the tidal phenomenon is a unique feature of every coast line.

(3) In spite of their complexity, the tides are amenable to mathematical analysis. As a result the exact time and the water level for a high tide as low tide can be forecast with great accuracy.

### **COMPONENTS OF TIDAL POWER PLANTS**

There are *three* main components of a tidal power plant *i.e.*

(i) The power house

(ii) The dam or barrage (low wall) to form pool or basin.

(iii) Sluice-ways from the basins to the sea and *vice versa*

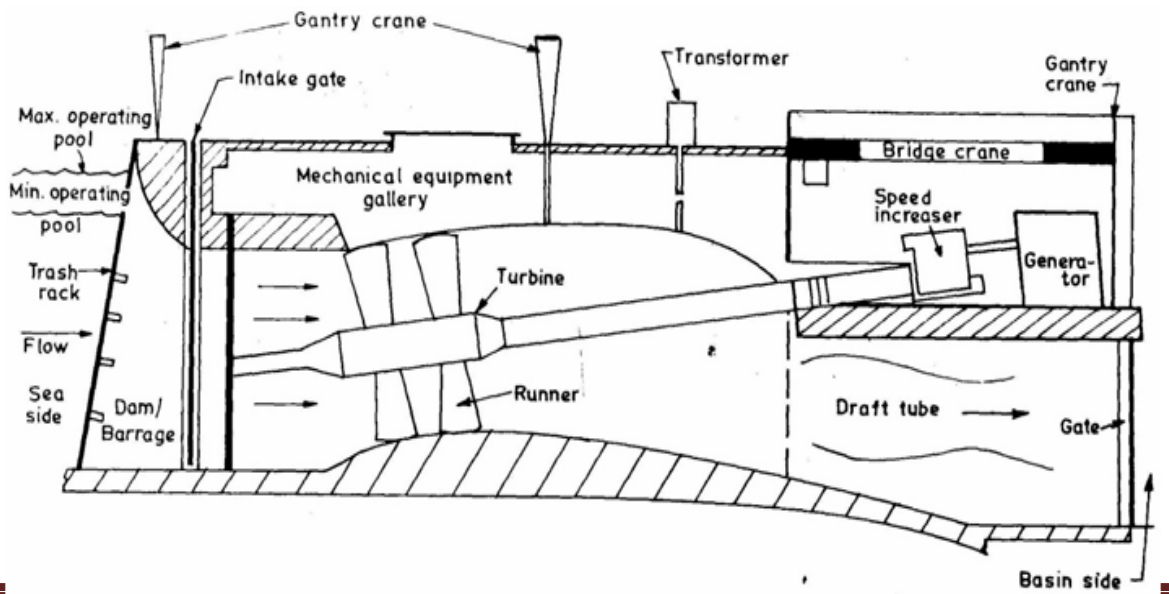

The turbine, electric generators and other auxiliary equipments are the main equipments of a power house. The function of dam to form a barrier between the sea and the basin or between one basin and the other in case of multiple basins.

The sluice ways are used either to fill the basin during the high tide or empty the basin during the low tide, as per operational requirement. These are gate controlled devices.

It is generally convenient to have the power house as well as the sluice-ways in alignment with the dam. The design cycle may also provide for pumping between the basin and the sea in either direction. If reversible pump turbines are provided, the pumping operation can be taken over at any time by the same machine.

The modern tubular turbines are so versatile that they can be used either as turbines or as pumps in either direction of flow. In addition, the tubular passages can also be used as sluice-ways by locking the machine to a stand still.

As compared to conventional plants, this, however, imposes a great number of operations in tidal power plants. For instance, the periodic opening and closing of the sluice-ways of a tidal plant are about 730 times in a year.

**Dam (Barrage).** Dam and barrage are synonymous terms. Barrage has been suggested as a more accurate term for tidal power schemes, because it has only to withstand heads a fraction of the structure's height, and stability problems are far more modest.

However, the literature does not always make the distinction, even though heads are small with tidal power cut offs.

Tidal power barrages have to resist waves whose shock can be severe and where pressure changes sides continuously.

Since barrage length adds also to the price tag of the plant, short barrages are preferred even if basin size may have to be smaller as a result of site choice. Up to a height of 20 m, cost remains proportional to length as it is not changed by the need to build a darn wall to withstand high hydrostatic pressure.

When, the elevation exceeds the 20 m limit, costs increase faster with length. Most tidal power plants do not have heads exceeding 20 m.

The barrage needs to provide channels for the turbines in prestressed or reinforced concrete. To build these channels a temporary cofferdam is necessary, but it is now possible to built them on land, float them to the site, and sink them into place.

Flatness is required for the sea bottom; sandy bottom usually necessitates piling. There, where sand or rock can bear the weight of the structure to be implanted, the bottom can be prepared, the structure placed on it and then anchored. Prefabricated concrete blocks can be used as the core for large barrages and voids filled with rocks or concrete remaining holes with sand, and the entire construction then asphalted.

Construction of a barrage usually will influence the tidal amplitude. Indeed, such a construction modifies the effective length of the embayment or basin and its shape as well, particularly if the scheme involves supplementary spur dams, or brings about relocation or disappearance of natural obstruction as is foreseen for the severn plant and has occurred in the Rance estuary.

The construction influence the resonance of the bay, and most bays are less than the resonant length of the tidal wave. If resonance is reduced, the range will decrease; if measures are taken to augment the resonance, tidal amplitude may be increased.

Tidal barrages require sites where there is a sufficiently high tidal range to glue a good head of water—the minimum useful range is around three meters. The, best sites are bays and estuaries, but water can also be impounded behind bunded reservoirs built between two points on the same shore line.

The precise design of barrage and its mode of operation depend critically on the requirements for power and on a careful analysis of the economics. The simplest and cheapest schemes would normally involve —a-single barrage designed to trap water in a basin at high tide and to generate on the ebb. More complex schemes could involve generation on both the ebb and flood tides, or the construction of a secondary basin which would permit water to be stored and discharged whenever desired. This would provide more firm power on a flexible basis.

The expertise necessary to design and build such structures is available. The location of the barrage is important, because the energy available is related to the size of the trapped basin and to the *square* of the tidal range. The nearer it is built to the mouth of an estuary or bay, the larger the basin, but the smaller the tidal range. A balance must also be struck between increased output and increased material requirements and construction costs. Gates and Locks.

Tidal power basins have to be filled and emptied. Gates are opened regularly and frequently but heads vary in height and on the side where they occur, which is not the case with conventional river projects. The gates must be opened and closed rapidly and this operation should use a minimum of power. Leakage, is tolerable for gates and barrage. Since we are dealing with sea water, corrosion problems are acute, they have been very successfully solved by the cathodic protection and where not possible by paint. Gate structures can be floated as modular units into place.

Though, in existing plants, vertical lift gates have been used, technology is about ready to substitute a series of flaps that operate by water pressure. Flap gates are gates that are positioned so as to allow water into the holding basin and require no mechanical means of operation. If used they, are positioned, in the case of modular construction, in the caissons.

A caisson is then floated into place. They have to be built so that they will be adequate for the maximum tidal amplitude. Top hung on a gate-hoisting beam, a gate would transfer its hydraulic load to the concrete structure. If operation is to be rapid and efficient, gates must open under the maximum differential head; this favours as flat as possible the tidal basin face of the sluice.



The flap gates allow only in the direction of the sea to basin. Hence, the basin level rises well above to sea level as ebb flow area is far less than flood flow area. Power House. Because small heads only are available, large size turbines are needed; hence, the power house is also a large structure. Both the French and Soviet operating plants use the bulb type of turbine.

Of the propeller type, with reversible blades, bulbs have horizontal shafts coupled to a single generator. The cost per installed kilowatt drops with turbine size, and perhaps larger turbines might be installed in a future major tidal power plant.

The Bulb Group (Rance Example). A bulb type turbine is an axial flow turbine the bulb set, resembling in appearance a small submarine, is made up of an ogive shaped steel shell containing an alternator and a Kaplan turbine. It is placed in a horizontal hydraulic duct and entirely surrounded by water; a shaft provides communication with the engine room of the power plant.

The set function as a turbine and as a pump, and regulates the flow in both directions of flow, tide to reservoir (basin) and reservoir to tide. –

The alternator is directly coupled to the turbine and turns it at some pressure. The turbine is a kaplan wheel with four mobile blades and guide vanes. The group, functioning as a turbine in the direct sense basin to sea, and furnishing power in reverse, sea to basin direction, functioning as a pump in direct sense.(Fig.).

Rim Type Turbines. Different types of turbines are under study; usually mentioned are included shaft turbines, rim type turbines, or straight flow turbines, where the generator is attached peripherally on the turbine blades, an arrangement that couples two turbines of conventional type to one generator, and a hydraulic system in which upto six turbines are coupled to hydrostatic pumps and to drive a pelton-wheel, which, in turn, drives a high speed generator.

The main problem in rim type turbine, in which the rotor surrounds the turbine runner as a rim carried by the runner blades, is the seals between the stationary parts and the rotating rim. Engineers who favour straight flow generators against the bulb turbine generators point out the lower inertia characteristic of the bulb type, claiming this could lead to problems during power system disturbances.

The designers of a new type of straight flow units put forth savings in civil works and in generator and auxiliary electrical equipment because large unit capacities than with the bulb type unit, for the same head, would be possible.

## OPERATION METHODS OF UTILIZATION OF TIDAL ENERGY

The generation of electricity from water power requires that there should be a difference in levels (or heads) between which water flows. A number of concepts have been proposed for generating electricity by utilizing the head that can be produced by the rise and fall of the tides to operate a hydraulic turbine.

The power generation from tides involves flow between an artificially developed basin and the sea. However in order to have a more or less continuous generation, this basic scheme can be elaborated by having two or more basins.

Accordingly we can distinguish the following types of arrangements:

- (1) Single basin arrangement,
- (2) Double basin arrangement.

Single-basin schemes can generate power only intermittently, but a double basin scheme can provide power continuously, or - on demand, which is a tremendous advantage. The drawback is that the civil works become more extensive. In the simplest double-basin scheme there must be a dam between each basin and the sea, and also a dam between the basins, containing the power house. One basin is maintained always at a lower level than the other.

The lower reservoir empties at low tide, and the upper reservoir is replenished at high tide. If the generating capacity is to be large, the reservoirs must be large, which usually means that the dams will be long.

(1) Single Basin Arrangement The simplest way to generate tidal power is to use a single basin with a retaining dam in the following manner: In a single basin arrangement there is only one basin interacting with the sea. The two are separated by a dam (or barrage) and the flow between them is through sluice ways located conveniently along the dam. Potential head is provided by rise and fall of tidal water levels, this is usually accomplished by blocking the mouth of a long narrow estuary with a dam across it, thereby creating a reservoir. The dam or

barrage embodies a number of sluice gates and low head turbine sets. The generation of power can be achieved in a single basin arrangement either as a

- (a) Single ebb-cycle system, or
- (b) Single tide-cycle system, or
- (c) Double cycle system.

**(a) SINGLE EBB CYCLE SYSTEM.** When the flood tide (high tide) comes in, the sluice gates are opened to permit sea-water to enter the basin or reservoir, while the turbine sets are shut. The reservoir thus starts filling while its level rises, till the maximum tide level is reached. At the beginning of the ebb tide the sluice gates are closed. Then the generation of power takes place when the sea is ebbing (flowing back of tide) and the water from the basin flows over the turbines into the lower level sea water. After two or three hours when there is sufficient difference between the full reservoir level and the falling tide level, to run the turbines, they are started and keep working until the rising level of the next flood tide and the falling reservoir level together reduce the effective head on the turbines to the extent where it can no longer work safely and efficiently. The turbines are then closed and the sluice gates opened again; to repeat the cycle of operations. Since in an estuary, the ebb tide has a long duration than the flood tide, the ebb operation provides an increased period of actual work.

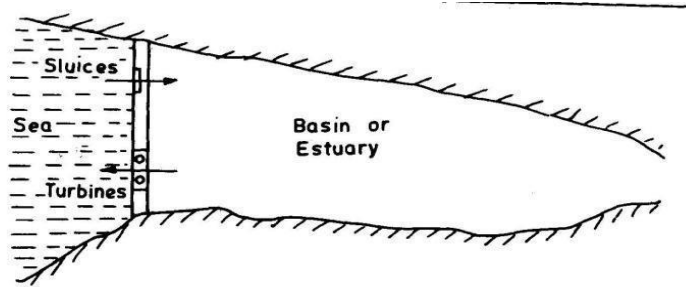

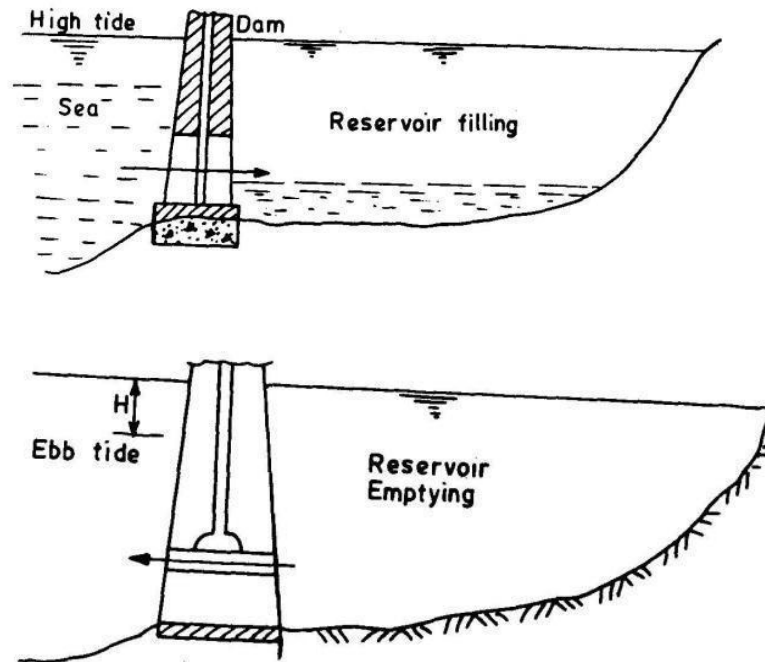

(b) Sluice gates open, Turbine shut off (Section).

(c) Sluice gates shut, Turbine operation (Section)

**FIG. TIDAL POWER PLANT (SINGLE BASIN OPERATION).**

**(B) SINGLE TIDE CYCLE SYSTEM.** In single tide cycle system, the generation is affected when the sea is at flood tide. The water of the sea is admitted into the basin over the turbines. As the flood tide period is over and the sea level starts falling again, the generation is stopped. The basin is drained into the sea through the sluice ways.

Flood operation scheme needs larger size plant, operating, for shorter period and hence less efficient as compared to ebb tide operation. The ebb operation plant will be of smaller size,

but will operate over a large period. The aim and effort should be to obtain as long a period of operation as possible at the beginning and finishing the work at the minimum operating head. Adjustable blade bulb turbines are specially suited for such operations under low and variable

heads. All these turbines may be reversible which can work as pumps after the high tide, to increase the amount of water in the storage lake, until the generation can start. This way the turbine operation period may be prolonged to ten or more hours, out of the twelve hours-twenty five minutes of the tidal cycle.

The tide-cycle requires a deeper reservoir so as to locate the sills of the sluice gates deeper and, thus, requires greater construction costs. It has been estimated that the energy produced by an ebb cycle system can be as much as 1.5 times that by a tide cycle system. The main disadvantage in both the ebb-cycle as well as the tide cycle systems is the intermittent nature of their operation. However, since the intermissions occur at regular intervals, there is possibility of connecting another supplementary system, so as to balance the discontinuity. Such possibilities can regulate the output. The system can be so geared as to generate power, both during the ebb and flood tides with the help of single basin only. This system is known as the double-cycle system.

**(C) DOUBLE CYCLE SYSTEM.** As stated above in double cycle system, the power generation is affected during the ebb as well as in flood tides. The direction of flow through the turbines during the ebb and flood tides alternates, but the machine acts as a turbine for either direction of flow. In this method, the generation of power is accomplished both during emptying and filling cycles. Both filling and emptying processes take place during short periods of time, the filling when the ocean is at high tide while the water in the basin is at low tide level, the emptying when the ocean is at low tide and the basin at high-tide level. The flow of water in both directions is used to drive a number of reversible water turbines, each driving an electrical generator. Electric power would thus be generated during two short period during each tidal period of 12 h, 25 mm. or once every  $Gh$ , 12.5 mm.



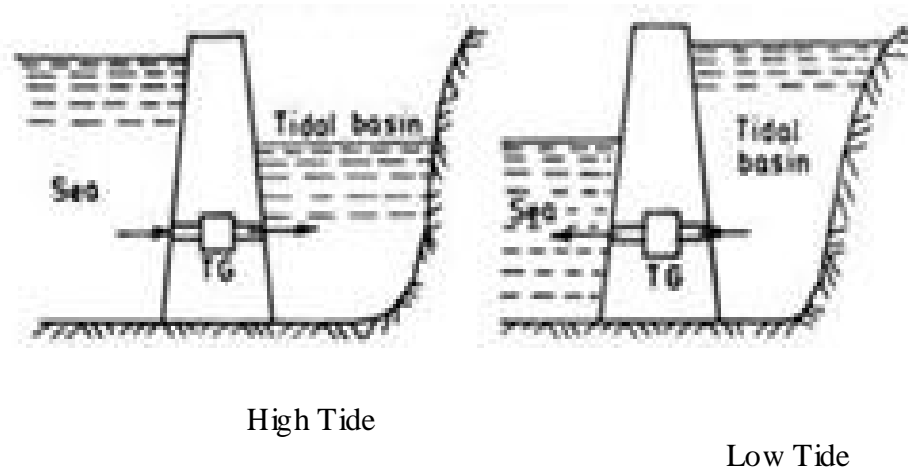

**Fig. Double Cycle System**

Though the double cycle system has only short duration interruptions in the turbine operation, yet a continuous generation of power is still not possible. Furthermore the periods of power generation coincide only occasionally with periods of peak demand. These problems are solved to some extent in the two-basin scheme described below. However, a fundamental

drawback to all methods for generating tidal power is the variability in output caused by the variations in the tidal range.

## (2) Double Basin Arrangement

It requires two separate but adjacent basins. In one basin called “upper basin” (or high pool), the water level is maintained above that in the other, the low basin (or low pool). Because there is always a head between upper and lower basins, electricity can be generated continuously, although at a variable rate.

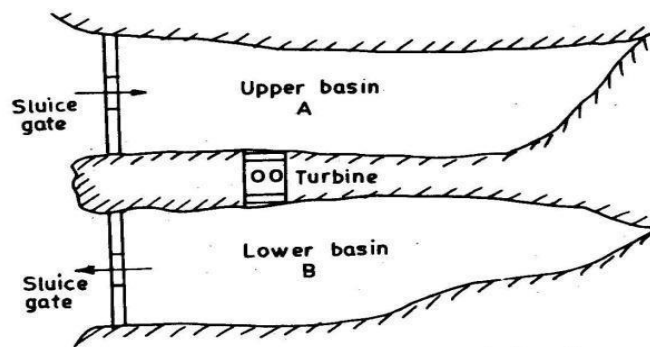

**Fig. Tidal power plant Double Basin Operation.**

In this system **the turbines** are located in between the two adjacent basins, while the sluice gates are as usual embodied in the dam across the mouths of the two estuaries. At the beginning of the flood tide, the turbines are shut down, the gates of upper basin A are opened and those of the lower basin B are closed. The basin A is thus filled up while the basin B remains empty. As soon as the rising water level in A provides sufficient difference of head between the two basins, the turbines are started. **The water** flows from A to B through the turbines, generating power. The power generation thus continues simultaneously with **the filling up the** basin A. At the end of the flood tide when A is full and **the water level in it is the** maximum, its sluice gates are closed. When **the ebb** tide level gets lower than the water level in B, its sluice gates are opened whereby the water level in B, which was arising and reducing the operating **head**, starts falling with the ebb. This continues until **the head and water level in A** is sufficient to run the turbines. With the next flood tide the cycle repeats itself. With this twin basin system, a longer and more

continuous period of generation per day is possible. The small gaps in the operation of such stations can be filled up by thermal power.

The operation of the two basin scheme can be controlled so that there is a continuous water flow from upper to lower basin. However since the water head between the basins varies during each tidal cycle, as well as from day to day, so also does the power generated. As in the case with single basin scheme, the peak power generation does not often correspond in time with the peak demand. **One** way of improving the situation is to use off-peak power, from the tidal power generators or from an alternative system, to pump water from the low basin to the high basin. An increased head would then be available for tidal power generation at times of peak demand. This is very similar to pumped storage system in hydro-electric power stations.

### **Estimate of Energy and Power in Simple Single Basin Tidal System**

The expression of maximum energy that can be generated during one generation period can be derived with the help of Fig. which shows the case of the basin beginning at high-tide level, emptying through the turbine to the ocean, which is at low tide. (The identical energy will be generated in reverse process).

During the emptying process, the differential work done by the water is equal to its potential energy at the time. Considering a tidal range  $R$ , and intermediate head, at a given time, the amount of work is calculated, considering a small head  $dh$ , for a intermediate head  $h$ , as shown in figure.

We can write

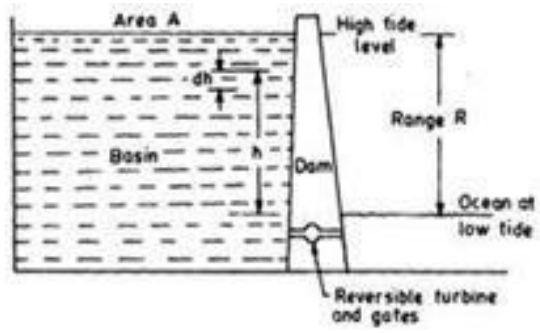

$$dw = dm \cdot g \cdot h$$

but  $dm = -\rho \cdot A \cdot dh$

so that  $dw = -\rho \cdot A \cdot dh \cdot gh$

where  $W$  = workdone by water, kcal/kg or Joule.

$g$  gravitational constant

$m$  = mass flowing through turbine, kg

$h$  = head m

$\rho$  = water density, kg/m<sup>3</sup>

The total theoretical work during a full emptying (or filling) period is obtained by integrating the expression i.e.

$$w = -g \rho A$$

$$= -g \rho A R^2$$

*The work is proportional to square of the tidal range. The power is the rate of doing work.*

The power is generated during emptying (or filling) and ~~no power~~ is generated during rest of the time. The *average theoretical power delivered* by the water is  $W$  divided by the total time it takes each period to repeat itself. Duration is 6 h, 12.5 minutes as shown in Fig. (6h, 12.5 minutes = 22,350 seconds).

Assuming an average sea water density = 1025 kg/m<sup>3</sup>, the average power per unit basin area is given by

$$= 0.225 R^2 \text{ watts/m}^2 \text{ (MW/kin}^2)$$

The actual power generated by a real tidal system would be less than the average theoretical power obtained by the above expressions due to frictional losses and conversion efficiencies of turbine and electric generators. The actual power generated may be about 25 to 30 per cent of the theoretic power.

## SITE REQUIREMENTS

The utilization of tidal energy requires construction of a barrier (or barriers) across a narrow inlet to an estuary or bay, thus forming an enclosure (or basin) in which ocean water can be impounded. Electricity can be generated by allowing water to flow through a turbine from the basin filled at high tide to the open ocean during falling tides and also as the basin is being filled from the ocean during rising tides.

In each case, the maximum amount of electrical energy that can be generated depends on the product of the tidal range ( $R$ ) and the mass (or volume) of water flowing through the turbine. The volume is equal to the range multiplied by the area of the impounded water. Hence, the electrical energy is proportional to the square of the range and the area of the enclosed basin. A favorable site for a tidal power plant should then have a large tidal range, and the geographic features should permit enclosure of large areas with reasonably short dams or other barrages. Sluice gates in the dams permit water to pass to or from the enclosed basin (or basins).

**Storage:** Storage is necessary when alternative electricity production schemes are not, or can not be, connected with the electrical grid. Tidal power plants are not an exception to this rule; there is a strong case for associating them with storage to provide for the varying needs of the consumer, also taking into account the eventual presence close-by of other plants. The tidal power plant has, by its very nature, many of the components required of a pumped storage

scheme. It has also the advantage that, with such a scheme, added tidal power becomes a fine day time source of power.

This is important because the principal saving provided by tidal energy is that of fuel, and probably also of pollution abatement costs. The fuel saved depends on the type of plant whose load factor is reduced and how such plants perform with the addition of tidal power or without it. Evidently, this argument applies only to highly developed countries where there are numerous other plants, and for less to developing countries.

The alternate to storage, when energy is available (but power is not needed because of timing), is not to generate, but the potential thus left untapped is not recoverable at a later time. It is pretty much a case of “store it or you will never have it when needed and no potential is available”. Hence the extra capital investment may well be justified.

For tidal power being produced in ‘mechanical form’ only *batteries*, *compressed air*, and *hydraulic storage* can be considered. Flywheel could be used, but its technology is not yet ready.

**Flywheel Storage:** By connecting a flywheel to a motor/generator, it is spinned up to high speed and absorbs energy. This energy can be returned to the motor—generator by decreasing the flywheel’s speed. However only small quantities can be stored, and they are limited to short periods of time.

**Batteries Storage:** Perhaps most flexible and practical are electro-chemical batteries. These batteries are the most common, but researches being conducted with less expensive and lighter types. Also presently available are aqueous solution nickel and nickel cadmium types, but they are much more costly. Again, this type of storage is suited to small plants, particularly self contained ones.

**Hydraulic Storage:** Hydraulic (or pumped—water) storage is most frequently mentioned in connection with tidal power plants. Two reservoirs, at different elevations, are linked by pumps

and turbines and their motors and generators. They constitute the accumulator (a reversible pump-turbine, connected to motor-generator achieves the same result). Off-peak energy, which



could be used, is put to work to pump water from the lower into the upper reservoir, which can be run through the turbine and generator and provide energy when needed at a later time. Power can be provided immediately on demand; storage stabilizes an otherwise intermittent source and constitutes an efficiency improvement, Reservoirs must be found or built, of course, and a certain amount of energy is lost, to activate and work the pump. Compressed Air Storage. Air is compressed during off-peak periods and thus stored underground. It can then be called upon to work gas turbines and provide electricity. Tidal energy can be used directly to drive air turbo compressors.

## **ADVANTAGES AND LIMITATIONS OF TIDAL POWER GENERATION**

### **Advantages:**

- (1) The biggest advantage of the tidal power is besides being inexhaustible it is completely independent of the precipitation (rain) and its uncertainty. Even a continuous dry spell of any number of years can have no effect whatsoever on the tidal power generation.
- (2) Tidal power generation is free from pollution, as it does not use any fuel and also does not produce any unhealthy waste like gases, ash, atomic refuse.
- (3) These power plants do not demand large area of valuable land because they are on the bays (sea shore).
- (4) Peak power demand can be effectively met when it works in combination with thermal or hydroelectric system.

### **Limitations:**

There are a number of reasons, why the tidal power generation is still a novelty, rather than a normal source of energy. The reasons can be enumerated as below:

- (1) The fundamental drawback to all methods of generating tidal power is the variability in

output caused by the variations in the tidal range.

(2) The tidal ranges are highly variable and thus the turbines have to work on a wide range of head variation. This affects the efficiency of the plant.

(3) Since the tidal power generation depends upon the level difference in the sea and an inland basin, it has to be an intermittent operation, feasible only at a certain stage of the tidal cycle. This intermittent pattern could be improved to some extent by using multiple basins and a double cycle system.

(4) The tidal range is limited to a few meters. Thus the bulb turbine technology was not well developed, use of conventional kaplan runners was the only alternative. This was found to be unsuitable. **Now with the development of reversible flow bulb turbines, this difficulty is overcome.**

(5) The duration of power cycle may be reasonably constant but its time of occurrence keeps in changing, introducing difficulties in the planning of the load sharing every day in a grid. This handicap can be removed now with the help of computerized programming.

(6) Sea water is corrosive and it was feared that the machinery may get corroded. Stainless steel with high chromium content and a small amount of molybdenum and the aluminium bronzes proved to be good corrosion resistant at La Rance project. The vinyl paint exhibited good results.

(7) Construction in sea or in estuaries is found difficult.

(8) Cost is not favourable compared to the other sources of energy.

(9) It is feared that the tidal power plant would hamper the other natural uses of estuaries such as fishing, or navigation.

### **PROSPECTS OF TIDAL ENERGY IN INDIA**

The possible sites for tidal power generation in India are obviously those where high tidal ranges occur e.g. Gulf of Cambay (Bhavnagar Sonrai), Gulf of Kutch (Kandla, Navalakhi) and of Houghly river. The maximum tidal range in the Gulf of Cambay (10.8 m) and is attractive for a tidal plant.

There are two possible sites on the western bank namely, Sonrai creek and Bhavnagar creek which have the essential requirements for locating probable plants. However, the silt change of the Gulf of Cambay is about 5000 ppm which is thought to be high and needs a closer study for future development. Gulf of Kutch has a maximum spring tide range of 7.5 m. The silt change here (near Navalakhi in the Gulf of Kutch) is much lower (nearly 1000 ppm). The tidal ranges and power potential of these sites are indicated in the table below.

There is at present no indication regarding the cost of generation from tidal power. Preliminary studies already carried out by the CPWD and for tidal station in the Gulf of Cambay indicated higher cost of generation from conventional sources. However, the cost of coal and other allied materials is increasing which may open up the possibility of exploitation of this source of power. Adequate data will have to be collected for any realistic assessment of tidal power potential and possible impact on the environment, current patterns, tidal reflections, sedimentation, erosion etc. Detailed feasibility reports based on full technology assessment are called for before

venturing into this field.

**Table: Tidal Power Plant in India.**

| Sites                   | Spring Tidal range in metres | Assumed area in Sq. kms | Tidal                    | Single Basin Cycle<br>MW 10 <sup>8</sup> | Two basins                    |         |                           |       |     |
|-------------------------|------------------------------|-------------------------|--------------------------|--|-------------------------------|---------|---------------------------|-------|-----|
|                         |                              |                         | Maximum Potential Energy |  | Alternatively operating MW108 |         | Cooperating MW108 kWh/yr. |       |     |
|                         |                              |                         |                          | kW/yr.                                   |                               | kWh/yr. |                           |       |     |
| Gulf of Kutch Navalakhi | 7.5                          | 10                      | 1110                     | 43                                       | 376                           | 48      | 419                       | 16.4  | 143 |
| Gulf of Cambay          | 10.8                         | 10                      | 2300                     | 89.4                                     | 784                           | 100     | 880                       | 34.2  | 300 |
| Sagar                   | 4.85                         | 10                      | 464                      | 18                                       | 157                           | 20.1    | 176                       | 6.9   | 60  |
| Diamond Harbour         | 3.9                          | 10                      | 686                      | 26.6                                     | 233                           | 29.7    | 262                       | 10.15 | 89  |

## Module-5

### INTRODUCTION

Broadly the ocean sources of energy are Ocean Thermal Energy Conversion (OTEC) and the Tidal energy, Wave energy and fourth form of the energy that emanates from the sun-ocean system stems from the mechanism of surface water evaporation by solar heating i.e. hydrological cycle.

These energy sources (except tidal) are the result of the absorption by the seas and oceans of solar radiation, which causes, like the wind, ocean currents and moderate temperature gradients from the water surface downward, especially in tropical waters. The oceans and seas constitute some 70 per cent of the earth's surface area, so they represent a rather large storage reservoir of the solar input.

The conversion of solar energy stored as heat in the ocean into electrical energy by making use of the temperature difference between the warm surface water and the colder deep water. The facilities proposed for achieving this conversion are commonly referred to as OTEC plants or sometimes as solar sea power plants (SSPP).

Since the ocean waters are heated by the sun, they constitute a virtually in- exhaustible source of energy. However, unlike direct solar energy, the ocean energy is available continuously rather than only in the daytime.

The operation of the OTEC plant is based on a well-established physical (thermodynamic) principle. If a heat source, is available at a higher temperature and a heat sink at a lower temperature, it is possible in principle, to utilize the temperature difference in a machine or prime mover (e.g. a turbine) that can convert part of the heat taken up from the source into mechanical energy and hence into electrical energy. The residual heat is discharged to the sink at the lower temperature.

In the OTEC system, the warm ocean surface water is the heat source and the deep colder water provides the sink.

The temperature gradient can be utilized in a heat engine to generate power. This is called ocean thermal energy conversion (OTEC).

### **Ocean Thermal Electric Conversion (OTEC)**

The ocean thermal energy concept was proposed as early as 1881 by the French physicist Jacques d' Arsonval. In this indirect form of solar energy at sea, collection and storage are free. The surface of the water acts as the collector for solar heat while the upper layer of the sea constitutes infinite heat storage reservoir.

Thus heat contained in the oceans, which is solar in origin could be converted into electricity by utilizing the fact that the temperature difference between the warm surface water of the tropical oceans and the colder waters in the depths is about 20-25°K.

Warm surface water could be used to heat some low boiling organic fluid, the vapour of which would run a heat engine. The exit vapour would be condensed by pumping cold water from the deeper regions. The amount of energy available for ocean thermal power generation is enormous, and is replenished continuously.

Solar energy absorption by the water takes place according to Lambert's law of absorption, which states that each layer of equal thickness absorbs the same fraction of light that passes through it.

Where  $I_0$  and  $I(x)$  are the intensities of radiation at the surface ( $x = 0$ ) and at a distance  $x$  below

the surface.  $K$  is an extinction coefficient (or absorption coefficient) that has the unit  $k$  has

values of 0.05 for very clear fresh water, 0.27 for turbid fresh water and 0.50 for very salty water.

Thus the intensity decreases exponentially with depth and, depending upon  $K$ , almost all of the absorption occurs very close to the surface of deep waters.

Because of heat and mass transfer at the surface itself, the maximum temperatures occur just below the surface.

Considering deep water in general, the high temperatures are at the surface, whereas deep water remains cool. In the tropics, the ocean surface temperature often exceeds  $25^{\circ}\text{C}$ , while 1 km below, the temperature is usually not higher than  $10^{\circ}\text{C}$ . Water density decreases with an increase in temperature (above  $4^{\circ}\text{C}$  where pure water's density is maximum, decreasing again below this temperature, the reason ice floats).

Thus there will be no thermal convection currents between the warmer, lighter water at the top and deep cooler, heavier water. Thermal conduction heat transfer between them across the large depths, is too low to alter this picture, and thus mixing is retarded, so the warm water stays at the top and the cool water stays at the bottom. It is said, therefore, that in tropical waters there are two essentially infinite heat reservoirs, a heat source at the surface at about  $27^{\circ}\text{C}$  and a heat sink, some 1 km directly below, at about  $4^{\circ}\text{C}$ ; both reservoirs are maintained annually by solar incidence. The concept of ocean thermal energy conversion (OTEC) is based on the utilization of this temperature difference in a heat engine to generate power.

The surface temperatures (and temperature differences) vary both with latitude and season, both being maximum in tropical, subtropical, and equatorial waters i.e., between the two tropics, making these waters the most suitable for OTEC systems. Several such plants are built in France after World War II (the largest of which has a capacity of 7.5 MW).

With a  $22^{\circ}\text{K}$  temperature difference between surface and depths, such as exists in warmer ocean areas than in north sea, the Carnot efficiency is around 7%. This is obviously very low, and comparable to that expected from a flat plate collector.

In fact, by the time the overall efficiency has been reduced by using a practical engine (operating on a Rankine cycle say) together with heat exchangers, the propositions might seem hopeless.

One major difference between these two heat sources is that solar energy arrives with a  $10\text{W}$



power density, and requires a large acreage of flat-plate collector.

Whereas an ocean thermal gradient source can operate with a small area collector by pumping sufficient water through the heat collector. Indeed the attraction of the solar sea power plant lies in its present day engineering feasibility and possible competitive cost with fossil fuel power stations.

As stated the idea of ocean thermal energy conversion with a suitable working fluid was originated by d' Arsonval, but the technical feasibility of the open cycle system was demonstrated by Claude with an installation on the south coast of Cuba in 1929.

It was a remarkable achievement at the time. The electric power generated was 22 kilowatts with an overall efficiency more than 1 per cent. The hot and cold water were conducted through the long pipes to the machinery ashore. With the limited technology and cheap fuel at that time, there was then little prospect for economic feasibility.

A larger installation with two units totalling 7 megawatts was constructed on the Ivory coast by the French in 1956, but encountered troubles and was abandoned.

The process of OTEC, requires that the warm surface water and cold water from depth (about 1000-1500 m), be brought into proximity so they act as the heat source and the heat sink, respectively for a heat engine.

In other words, solar energy collected and stored as heat by the world's major oceans, can be converted into electricity through a generation process similar to that of conventional power plants, except that in the case of OTEC, no depletable fuel is required.

Furthermore, although there is some seasonal variation in the ocean thermal resource at a given OTEC power plant location, there is little diurnal variation.

Accordingly OTEC power plants are analogous to solar hydropower plants in that they smooth out the diurnal intermittence of the solar radiation, in contrast to other electric power options. OTEC power plants provide a potentially substantial renewable source of base load electricity, albeit located mainly at sea.

Although it is possible to find good land sites where OTEC power plants can be located, by bringing the warm and cold water onto shore via aqueducts (artificial canal/conduit), it is clear that such opportunities will be much limited on a global basis than the ample opportunities for generating substantial amounts of OTEC electricity abroad floating OTEC platforms. This is both because of the special technical requirements for on shore OTEC plants and because of the

limited market potential (at least in the near term) for OTEC electricity at such sites. (on shore

OTEC power plants will be viable mainly at locations where three requirements are all simultaneously satisfied with satisfactory economics:

(i) Coastal zone land must be available,

(ii) Sea floor must descend sufficiently rapidly from the shore based plant location; and

(iii) The seasonal availability of warm and cold water without undue gradation by the warm and cold water effluents from the OTEC plant must meet certain criteria. In any event, it is probable that available and attractive on shore and near shore OTEC power plant location will be populated early in the development and implementation of the OTEC concept, both as convenient locations for pilot and demonstration plants and because they will constitute attractive intermediate markets for OTEC electricity and by products.

OTEC power generation system gives less efficiency, as stated above. However, because of the OTEC requirement for parasitic power (such as for pumping up the cold water supply) and other losses, the achievable net conversion efficiency is only about 2.5 percent (Carnot efficiency 7%).

This compares a net efficiencies of 30 to 40% associated with conventional power

Some engineers question whether such as an extremely low net efficiency will ever allow OTEC to become economically viable. However, it is important to consider the matter in more sophisticated terms than net efficiency; since in the case of OTEC there is no fuel cost, only the requirement to pay for circulating much more warm and cold water, than is normally associated with power generation. This means that extensive areas heat exchangers will be required for "closed cycle" OTEC plants (which would employ a working fluid such as ammonia) or that degasifiers (to remove gases dissolved in the sea water) and tremendous turbines would be required for "open cycle" OTEC plants that would operate by the flash evaporation of sea water.

Thus, although the net efficiency of the JEC plant must certainly be positive and as high as is readily attainable, the key economics question is the resulting cost of OTEC electrical energy, not the actual value of the net efficiency.

## METHODS OF OCEAN THERMAL ELECTRIC POWER GENERATION:

There are two rather different methods for harnessing ocean thermal differences. One is the open cycle, also known as the Claude cycle, and other is the *closed cycle* system, also known as the Anderson cycle.

In the closed cycle system, a liquid working fluid, such as ammonia or propane, is vaporized in an evaporator (or boiler); the heat required for vaporization is transferred from the warm ocean surface to the liquid by means of a heat exchanger')

The high-pressure vapour leaving the evaporator drives an expansion turbine, similar to a steam turbine that it is designed to operate at a lower inlet pressure. The turbine is connected to an electric generator in the usual manner.

The low pressure exhaust from the turbine is cooled and converted back into liquid in the condenser. The cooling is achieved by passing cold, deep ocean water, from a depth of 700 to 900 or more, through a heat exchanger. T

The liquid working fluid is then pumped back as high pressure liquid to the evaporator, thus closing the

In the open-cycle turbine system, water is the working fluid. The warm surface water is caused to boil by lowering the pressure, without supplying any additional heater low-pressure steam produced then drives a turbine, and the exhaust steam is condensed by the deep colder water and is discarded.

A heat exchanger is not required in the evaporator and direct-contact between the exhaust steam and a cold- water spray makes a heat exchanger as necessary in the condenser.

On the other hand, because of the low energy content of the low pressure steam, very large turbines or several smaller units operating in parallel would be required to achieve a useful electric power output.

The Claude cycle or open cycle which is older one, utilizes the vapour pressure of sea water itself as the working medium and has been demonstrated to be practicable.

The other method, a closed cycle known as the Rankine cycle, uses a working fluid with higher vapour pressure (such as ammonia, hydrocarbon or halocarbon) at the temperature available.

This cycle is favoured for the future development in expectation of higher efficiency. The first published work on OTEC by d'. Arsonvol in 1881, suggests a closed cycle, and that article proposed sulfur di-oxide (SO<sub>2</sub>) as the working fluid. However, the first OTEC experiments by Claude in the 1920s utilized an open cycle where sea water was evaporated under a partial vacuum.

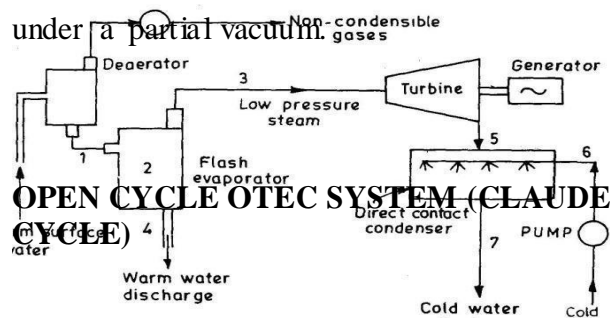

**OPEN CYCLE OTEC SYSTEM (CLAUDE CYCLE)**

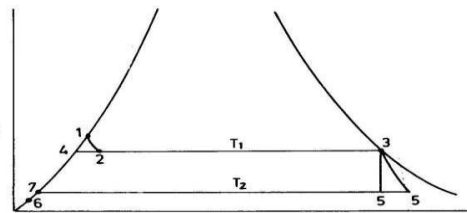

steam is passed through a turbine, which extracts energy from it, and then the spent vapour is cooled in a condenser.

This cycle drives the name 'open' from the fact that the condensate need not be returned to the evaporator, as in the case of the 'closed cycle'.

Instead, the condensate, can be utilized as desalinated water if a surface condenser is used, or if a spray (direct-contact) condenser is used, the condensate is mixed with the cooling water and the mixture is discharged back into the ocean. & schematic diagram of the open cycle system is shown in Fig.

'Open cycle' refers to the 'utilization of sea water as the working fluid, wherein sea water is flash evaporated under a partial vacuum. The low pressure

Its corresponding T-S diagram is also Fig. Schematic of the OTEC open cycle. shown in the Fig. In the cycle shown warm surface water at say 27°C is admitted into an evaporator in which the pressure is maintained at a value slightly below the saturation pressure

At the new pressure, water which is entering the evaporator gets 'super heated'. As shown in Fig. the warm water which is at 27°C, has a saturation pressure of 0.03619 kg/cm<sup>2</sup> (0.0356 bar) (point 1).

The evaporator pressure is 0.03213 (0.0317 bar), which corresponds to 25°C saturation temperature. This temporarily superheated water undergoes *volume boiling* (as opposed to pool boiling which takes place in conventional boilers due to an immersed heating surface), causing that water to partially flash to steam to an equilibrium two phase condition at the new pressure and temperature of 0.03213 kg/cm<sup>2</sup> and 25°C (point 2). Process 1-2 is a throttling and hence constant enthalpy process.

The low pressure in the evaporator is maintained by a vacuum pump that also removes the dissolved non-condensable gases from the evaporator.

At point 2, the evaporator contains a mixture of water and steam of very low quality. The steam is separated from the water as saturated vapour at 3.

The remaining water is saturated at 4 and is discharged as brine back to the ocean. The steam at 3, has a very low pressure and high specific volume (0.03213 kg/cm<sup>2</sup>, 43.40 m<sup>3</sup>/kg), as compared to conventional fossil power plant, which has about 160 kg/cm<sup>2</sup> pressure and 0.021 m<sup>3</sup>/kg specific volume.

The steam expands in a specially designed turbine that can handle such conditions to 5. The condenser pressure and temperature at point 5 are of the order of 0.01729 kg/cm<sup>2</sup> (0.017 bar) and 15°C. A direct contact condenser is used as the turbine exhaust steam will be discharged back to the ocean in the open cycle system. In the condenser, the exhaust steam is mixed with

cold water from the deep cold water pipe at 6, which results in near saturated water at 7. This water is allowed to be discharged to the ocean.

The cooling water from the deep ocean which is at about 11°C, on reaching the condenser, its temperature rises to about 15°C, due to heat transfer between the progressively warmer outside water and cooling water inside the pipe, as it ascends towards the top. It can be seen that very large ocean water mass and volume flow rates are used in open OTEC systems and that the turbine is a very low pressure unit that receives steam with specific volumes more than 2000 times that in a modern fossil power plant.

Thus the turbine resembles the few last exhaust stages of a conventional turbine and is thus physically large. Because of the need in the open cycle to harness the energy in low pressure steam, extremely large turbines (compared to wind turbines) must be utilized. Further-more degasifiers (deaerators) must be used to remove the gases dissolved in the sea water unless one is willing to accept large losses in efficiency.

On the other hand, since there are no heat transfer problems in the evaporator, the problem of bio-fouling control is minimized. The cost of an open-cycle system for providing substantial number of megawatts is presently regarded by most OTEC workers as being significantly greater than for closed cycle system. The turbine cost constituted almost half the cost of the power system, but may be amenable to reductions that could result from design innovations.

### **The Closed or Anderson, OTEC Cycle**

A schematic of a closed-cycle OTEC power plant is shown in Fig. Heat exchanger known as evaporators and condensers are a key ingredient, since extensive areas of material are needed to transfer significant amounts of low quality heat of the low temperature differences being exploited.

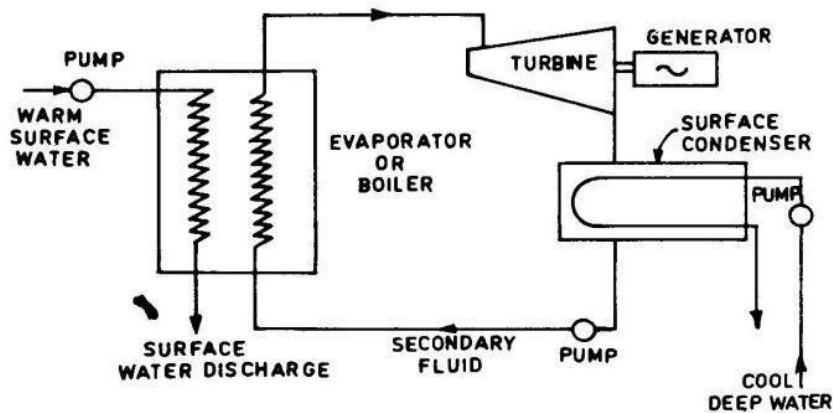
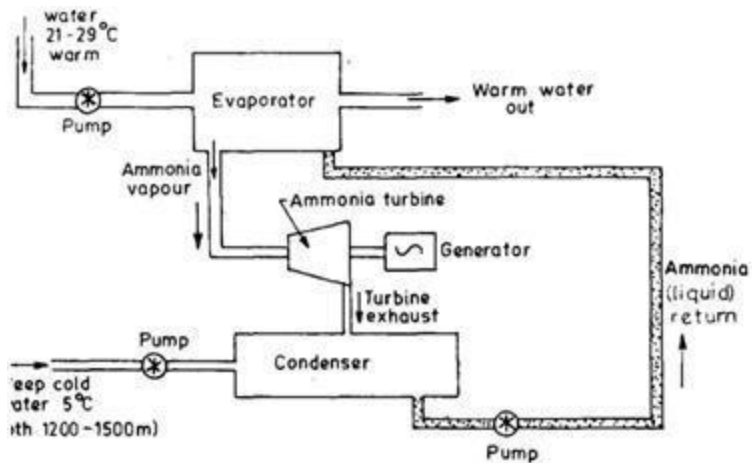

**Fig. Schematic of an OTEC closed cycle system.**

In other words, large volumes of water must be circulated through the OTEC power plant, requiring commensurately large heat exchangers. The actual components employed in an OTEC closed cycle system would appear more like the hardware illustrated in **Fig.2** another closed cycle schematic. This cycle requires a separate working fluid that receives and rejects heat to the source and sink *via* heat exchangers (boiler or evaporator and surface condenser). The working fluid may be ammonia, propane, or a Freon.

The operating of such fluids at the boiler and condenser temperatures are much higher than those of water, being roughly  $10 \text{ kg/cm}^2$  ( 10 bar) at the boiler, and their specific volumes are much lower, being comparable to those of steam in conventional power plants.

Such pressures and specific volumes result in turbines that are much smaller and hence less costly than those that use the low pressure steam of the open cycle. The closed cycle also avoids the problems of the evaporator. It however, requires the use of very large heat exchangers (boiler and condenser) because, for an efficiency of about 2 percent, the amounts of heat added and rejected are about 50 times the output of the plant. In addition, the temperature differences in the boiler and condenser must be kept as low as possible to allow for the maximum possible temperature difference across the turbine, which also contributes to the large surfaces of these



**Fig. 2.**Schematic of a closed OTEC ammonia cycle.

The closed cycle approach was first proposed by Barjot in 1926, but the most recent design was by Anderson and Anderson in the 1960s. The closed cycle is sometimes referred to as the Anderson Cycle. In the cycle propane was chosen as the working fluid. The temperature difference between warm surface and cool surface was 20°C. The cool surface was at about 600 m deep. Propane is vaporized in the boiler evaporator at about 10 kg/cm<sup>2</sup> (10 bar) or more and exhausted in 1 condenser at about 5 bar.

Instead of usual heavier and more expensive shell and tube heat exchangers, the Anderson OTEC system employs thin plate type heat exchangers, which minimizes the mass and the amount of material and hence cost. The heat exchangers are placed at depths where the static pressure of the water in either heat exchanger roughly equals the pressure of the working fluid, this helps in reducing the thickness of plates.

A fundamental requirement in closed cycle systems is to transfer heat efficiently across the heat exchanger surfaces constituting the evaporators and condensers, so as to achieve a high value of overall heat transfer coefficient ( $U$ ) measured in watts per kelvin per square meter or  $W/°K/m^2$ . For the evaporation, this overall heat transfer coefficient is a measure of how effectively heat is transferred sequentially from the surface water through the heat exchanger material (a metallic alloy) a



hence to the working fluid (*e.g.*, ammonia). For the condenser, an over U characterized the reverse heat transfer process.

In an ocean environment, it is likely that a layer of slime known as “bio fouling” will *eventually* accumulate on the water side of the heat exchangers. Such slime is first comprised of micro-organisms, at which stage, the bio fouling is called “micro fouling”. Subsequently, if the slime is not removed, additional bio-fouling in the form of micro-organisms will become attached, augmenting the slime layer. The occurrence of micro-fouling seems to be a pre-requisite for the attachment of macro organisms.

A film of corrosion and possibly of calcareous (*e.g.* minerals deposits) can also accumulate on the water side (and conceivably through leakage—even on the working fluid side of the heat transfer surfaces). The total formulation of bio-fouling, corrosion, and so on, referred to as “fouling” (or scaling) and will tend to inhibit heat transfer through it. The “fouling factor” is a measure of the thermal resistance  $R_f$  of a fouling film. This thermal resistance is the reciprocal of the corresponding heat transfer coefficient  $h_f$  of the fouling film.

To maintain viable OTEC heat exchangers, provisions must be made to inhibit the formation of fouling layers and to remove any significant fouling that forms. Removal can be accomplished by periodically cleaning the heat exchanger surfaces through mechanical, chemical or other means.

Although both closed and open cycle turbine systems are being explored, it appears that closed-cycle systems offer the most promise for the near future. Each of the possible working fluids (*i.e.* ammonia and propane) has advantages and disadvantages.

## **SITE SELECTION**

In selecting a site for an OTEC facility, the primary consideration is, of course, a significant temperature difference—at least about 20°C—between surface and deep ocean waters (for 700-900 m depth or more) that will permit year round operation.

The greater the difference, the lower will be the cost of generating electricity. The best sites are in the tropical belt between about 20°N and 20°S latitude. There are, however, several locations outside this area that might be suitable for OTEC plants. In choosing a site, consideration should be given to the potential for bio-fouling effects as noted earlier.

As a general rule, an OTEC plant would be located offshore in order to provide access to the deep colder water. However, an ideal situation might be one where the shoreline dropped steeply to a considerable depth. Most of the installation could then be more conveniently build on land.

## **ENERGY UTILIZATION**

If possible an OTEC plant should be less than about 30 km from shore. The electricity generated could then be transmitted inexpensively to land by submarine cable. At somewhat greater distances, the transmission costs would be increased but might be tolerable.

If the plant is so far from shore that these costs become prohibitive, the electricity generated can be utilized at the plant site to produce energy-intensive materials.

One suggestion is to use direct electric current to decompose sea water by the process of electrolysis; the main products would be hydrogen and oxygen. The hydrogen could be liquified and transported by tanker to a point where it could be used as fuel. Alternatively, the hydrogen could be combined with atmospheric nitrogen to form ammonia for use as fertilizer, thereby saving natural gas which is presently the main source of hydrogen for this purpose.

## HYBRID CYCLE

There are several variations on the standard OTEC open-cy system. One variation is the “hybrid cycle” which is an attempt combine the best features and avoid tlie worst features of the open closed cycles. First, as shown in Fig. 9.2.5.1, sea water is flash evaporated to steam, as in

the open cycle. The heat in the resul steam is then transferred to ammonia in an otherwise convent ional closed Rankine cycle system.

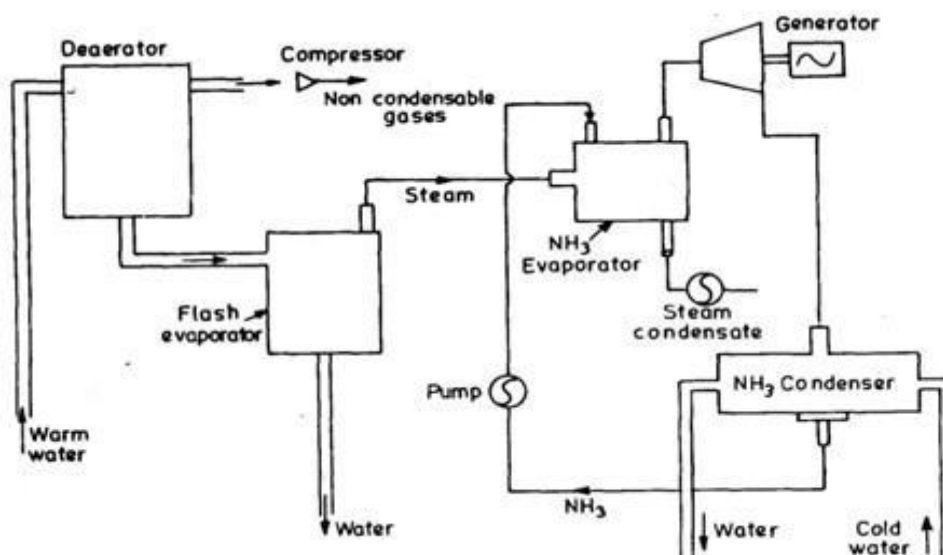

**Fig. Hybrid Cycle**

## **ROSPECTS OF OCEAN THERMAL ENERGY CONVERSION IN INDIA**

The OTEC project cell established at IIT, Madras has completed the preliminary feasibility study for establishing a, 1 MW OTEC plant in Lakshadweep Island at Minicoy. The OTEC works on the principle of utilizing the temperature difference of sea water at depth and that at the surface.

The surface sea water is used to vaporize a low boiling chemical which drives, a turbogenerator. The vaporized chemical is then compressed, it is condensed by using cold sea water from depth. Preliminary oceanographic studies on eastern side of Lakshadweep Island suggest the possibility of the establishment of shore based OTEC plant at the island with a cold water pipe line running down the slope to a depth of 800—1000 m.

Both the island has large lagoons on the western side. The lagoons are very shallow with hardly any nutrient in the sea water. The proposed OTEC plant will bring up the water from 1000 m depth which has high nutrient value. After providing cooling effect in the condenser, a part of deep sea water is proposed to be diverted to the lagoon for the development of aqua culture. A hydrographic survey of the proposed site was undertaken by National Hydrographic Office, Dehra Dun. The preliminary assessment of survey indicates the availability of suitable conditions for establishment of OTEC plant.