



## Module-5

# SYSTEM COMPENSATION

### LESSON STRUCTURE:

#### **Introduction:**

#### **System Compensation**

#### **Basic Characteristics of Lead, Lag And Lag-Lead Compensation:**

#### **Lag Compensator**

#### **Lead Compensator**

#### **Lag-Lead Compensator**

### OBJECTIVES:

- In order to obtain the desired performance of the system, we use compensating networks. Compensating networks are applied to the system in the form of feed forward path gain adjustment.
- To demonstrate to compensate a unstable system to make it stable.

### Introduction:

Automatic control systems have played a vital role in the advancement of science and engineering. In addition to its extreme importance in sophisticated systems in Space vehicles, missile- guidance, aircraft navigating systems, etc., automatic control system as become an important and integral part of manufacturing and industrial processes. Control of process parameters like pressure, temperature, flow, viscosity, speed, humidity, etc., in process engineering and tooling, handling and assembling mechanical parts in manufacturing industries among others in engineering field where automatic control systems are inevitable part of the system.

A control system is designed and constructed to perform specific functional task. The concept of control system design starts by defining the output variable( Speed, Pressure, Temperature Etc.,) and then determining the required specification ( Stability, Accuracy, and speed of response). In the design process the designs must first select the control Media and then the control elements to meet the designed ends.

In actual practice several alternative can be analyzed and a final judgment can be made an overall performances and economy.



Systems have been categorized as manual and automatic systems. Based on the type of control needed most systems are categorized as - Manual & Automatic. In applications where systems are to be operated with limited or no supervision, then systems are made automatic and where system needs supervision the system is designed as manual. In the present-day context most of the systems are designed as automatic systems for which one of the important considerations was economics. However, the necessity for the system to be made as an automatic system is to make sure that the system performs with no scope for error which otherwise is prone to a lot of errors especially in the operations. Other classification of a system is based on the input and output relationships. Accordingly, in an Open Loop Control System the output is independent of the input and in a closed loop control system the output is dependant on the input. The term input refers to reference variable and the output is referred to as Controlled variable. Most of the systems are designed as closed loop systems where a feedback path with an element with a transfer function would help in bridging the relationship between the input and the output. A system can be represented by the block diagram and from a simple to a complicated system, reduction techniques can be used to obtain the overall transfer function of the system. Overall system Transfer function can also be obtained by another technique using signal flow analysis where the transfer function of the system is obtained from Mason's gain formula. Once the system is designed, the response of the system may be obtained based on the type of input. This is studied in two categories of response namely response of the systemic time domain and frequency domain. The system thus conceived and designed needs to be analyzed based on the same domains. At this stage the systems are studied from the point of view of its operational features like Stability, Accuracy and Speed of Response. Development of various systems have been continuous and the history of the same go back to the old WATT'S Speed Governor, which was considered as an effective means of speed regulation. Other control system examples are robot arm, Missile Launching and Guidance System, Automatic Aircraft Landing System, Satellite based digital tracking systems, etc to name a few. In the design of the control systems, three important requirements are considered namely **STABILITY, ACCURACY and SPEED OF RESPONSE.**

Stable Systems are those where response to input must reach and maintain some useful value within a reasonable period of time. The designed systems should both be Unstable Systems as unstable control systems produce persistent or even violent oscillations of the output and output will be driven to some extreme limiting value.



Systems are also designed to meet certain levels of **Accuracy**. **This is a** relative term with limits based upon a particular application. A time measurement system may be from a simple watch to a complicated system used in the sports arena. But the levels of accuracy are different in both cases. One used in sports arena must have very high levels of sophistication and must be reliable showing no signs of variations. However, this feature of the system is purely based on the system requirement. For a conceived, designed and developed system, the higher the levels of Accuracy expected, higher is the Cost.

The third important requirement comes by way of SPEED OF RESPONSE. System must complete its response to some input within an acceptable period of time. System has no value if the time required to respond fully to some input is far greater than the time interval between inputs

### System Compensation

Compensation is the minor adjustment of a system in order to satisfy the given specifications. Specification refers to the objective of a system to perform and obtain the expected output after the system is provided with a proper input. Some of the needs of the system compensation are as specified.

### Basic Characteristics Of Lead, Lag And Lag-Lead Compensation:

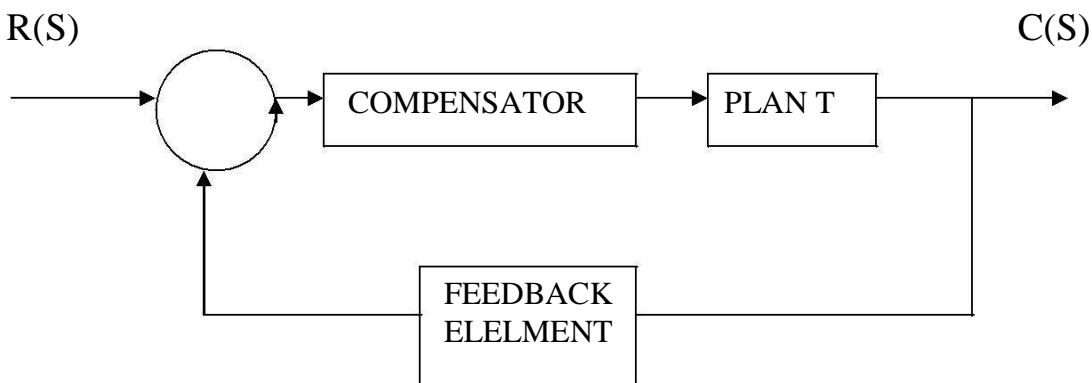

Lead compensation essentially yields an appropriate improvement in transient response and a small improvement in steady state accuracy. Lag compensation on the other hand, yields an appreciable improvement in steady state accuracy at the expense of increasing the transient response time. Lag-lead compensation combines the characteristics of both lead compensation and lag compensation. The use of a lag-lead compensator raises the order of the system by two



(unless cancellation occurs between the zeroes of the lag- lead network and the poles of the uncompensated open- loop transfer function), which means that the system becomes more complex and it is more difficult to control the transient response behavior. The particular situation determines the type of the compensation to be used.

## Lag Compensator

The Lag Compensator is an electrical network which produces a sinusoidal output having the phase lag when a sinusoidal input is applied. The lag compensator circuit in the 's' domain is shown in the following figure.

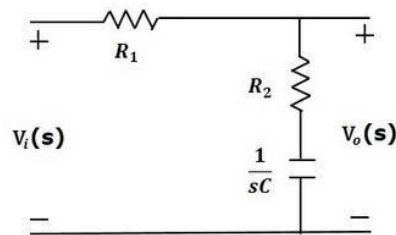

Here, the capacitor is in series with the resistor  $R_2$  and the output is measured across this combination.

The transfer function of this lag compensator is –

$$\frac{V_o(s)}{V_i(s)} = \frac{1}{\alpha} \left( \frac{s + \frac{1}{\tau}}{s + \frac{1}{\alpha\tau}} \right)$$

Where,

$$\tau = R_2 C$$

$$\alpha = \frac{R_1 + R_2}{R_2}$$

From the above equation,  $\alpha$  is always greater than one. We know that, the phase of the output sinusoidal signal is equal to the sum of the phase angles of input sinusoidal signal and the transfer function. So, in order to produce the phase lag at the output of this compensator, the phase angle of the transfer function should be negative. This will happen when  $\alpha > 1$ .

## Lead Compensator

The lead compensator is an electrical network which produces a sinusoidal output having phase lead when a sinusoidal input is applied. The lead compensator circuit in the 's' domain is shown in the following figure.

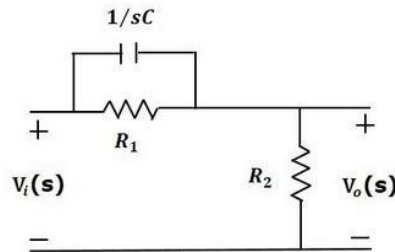

Here, the capacitor is parallel to the resistor  $R_1$  and the output is measured across resistor  $R_2$ . The transfer function of this lead compensator is –

$$\frac{V_o(s)}{V_i(s)} = \beta \left( \frac{s\tau + 1}{\beta s\tau + 1} \right)$$

Where,

$$\tau = R_1 C$$

$$\beta = \frac{R_2}{R_1 + R_2}$$

We know that, the phase of the output sinusoidal signal is equal to the sum of the phase angles of input sinusoidal signal and the transfer function. So, in order to produce the phase lead at the output of this compensator, the phase angle of the transfer function should be positive. This will happen when  $0 < \beta < 1$ . Therefore, zero will be nearer to origin in pole-zero configuration of the lead compensator.

## Lag-Lead Compensator

Lag-Lead compensator is an electrical network which produces phase lag at one frequency region and phase lead at other frequency region. It is a combination of both the lag and the lead compensators. The lag-lead compensator circuit in the 's' domain is shown in the following figure.

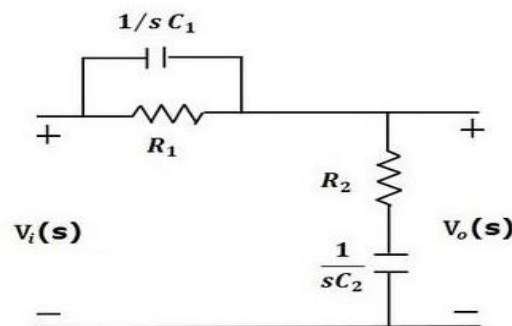

This circuit looks like both the compensators are cascaded. So, the transfer function of this circuit will be the product of transfer functions of the lead and the lag compensators.



$$\frac{V_o(s)}{V_i(s)} = \beta \left( \frac{s\tau_1 + 1}{\beta s\tau_1 + 1} \right) \frac{1}{\alpha} \left( \frac{s + \frac{1}{\tau_2}}{s + \frac{1}{\alpha\tau_2}} \right)$$

We know  $\alpha\beta = 1$ .

$$\Rightarrow \frac{V_o(s)}{V_i(s)} = \left( \frac{s + \frac{1}{\tau_1}}{s + \frac{1}{\beta\tau_1}} \right) \left( \frac{s + \frac{1}{\tau_2}}{s + \frac{1}{\alpha\tau_2}} \right)$$

Where,

$$\tau_1 = R_1 C_1$$

$$\tau_2 = R_2 C_2$$

### OUTCOMES:

At the end of the unit, the students are able to:

- obtain the desired performance of the system, we use compensating networks. Compensating networks are applied to the system in the form of feed forward path gain adjustment.
- Differentiate different types of compensators.

### SELF-TEST QUESTIONS:

1. Define compensators. What is the need of compensators in a system.
2. Explain with a sketch Lag compensator.
3. Explain with a sketch Lead compensator.
4. Explain with a sketch Lag-Lead compensator.
5. Explain basic components of Lag - Lead compensator.