

**Module – 4**

**Staircases**

- 4.1.1 Introduction
- 4.1.2 Objectives
- 4.1.3 Types of staircases
- 4.1.4 Structural classification
- 4.1.5 Problems
- 4.1.6 Outcomes
- 4.1.7 Assignment questions
- 4.1.8 Future study

### 4.1.1 Introduction

The staircase is an important component of a building, and often the only means of access between the various floors in the building. It consists of a *flight* of steps, usually with one or more intermediate *landings* (horizontal slab platforms) provided between the floor levels. The horizontal top portion of a step (where the foot rests) is termed *tread* and the vertical projection of the step (i.e., the vertical distance between two neighbouring steps) is called *riser*. Values of 300 mm and 150 mm are ideally assigned to the tread and riser respectively — particularly in public buildings. However, lower values of tread (up to 250 mm) combined with higher values of riser (up to 190 mm) are resorted to in residential and factory buildings. The *width* of the stair is generally around 1.1 – 1.6m, and in any case, should normally not be less than 850 mm; large stair widths are encountered in entrances to public buildings. The horizontal projection (plan) of an inclined flight of steps, between the first and last risers, is termed *going*. A typical flight of steps consists of two landings and one going, as depicted in Fig. Generally, risers in a flight should not exceed about 12 in number. The steps in the flight can be designed in a number of ways: with *waist slab*, with *tread-riser* arrangement (without waist slab) or with *isolated tread slabs* — as shown in Fig respectively.

### 4.1.2 Objectives

1. To design a dog-legged and open newel staircases

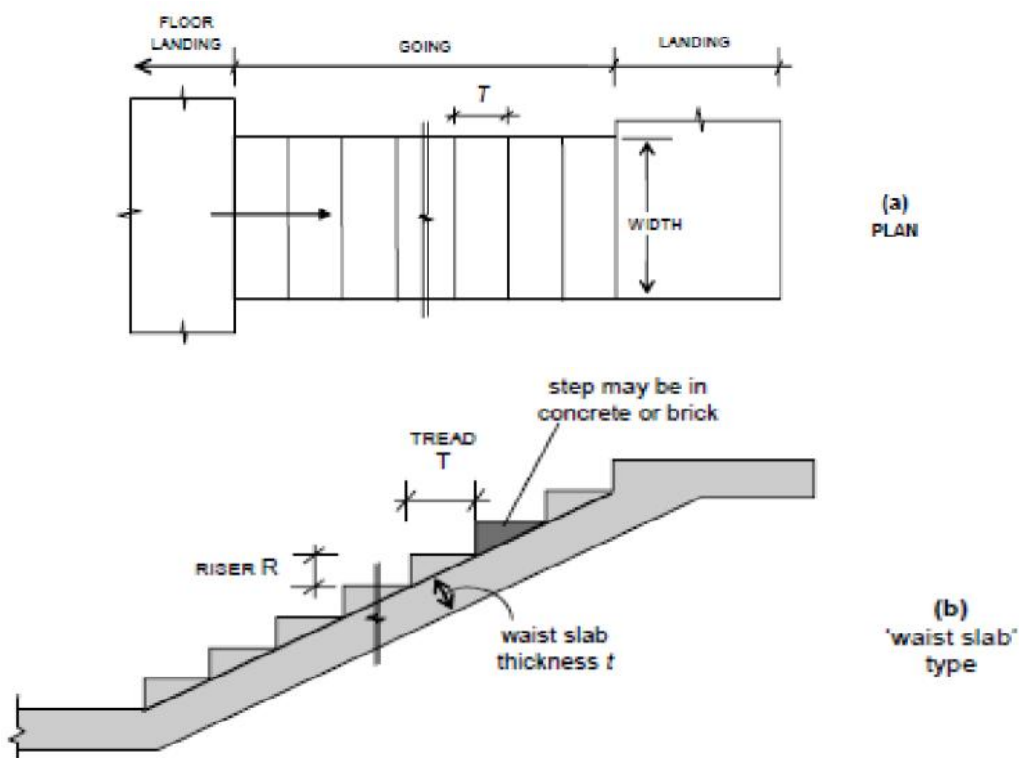

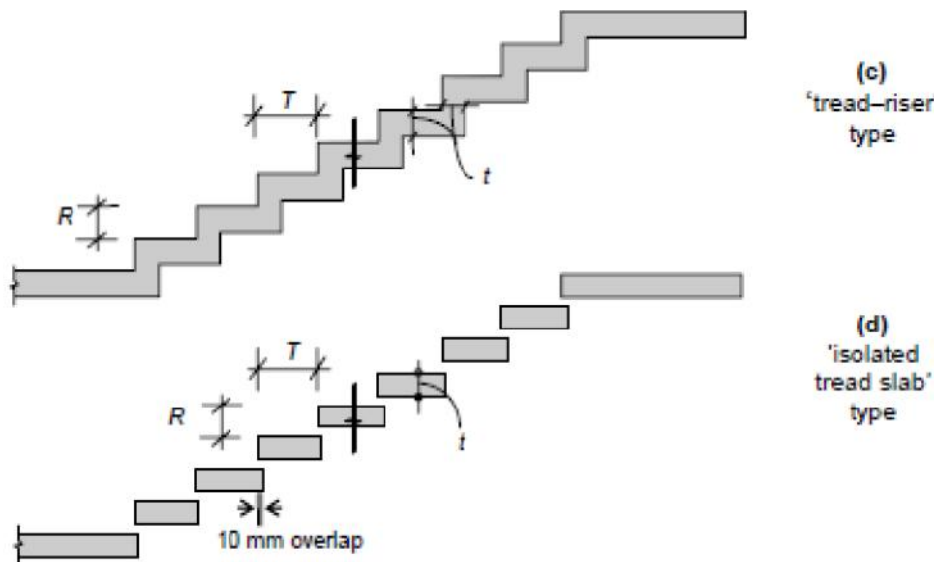

A typical flight in a staircase

**4.1.3 TYPES OF STAIRCASES**

Geometrical Configurations

A wide variety of staircases are met with in practice. Some of the more common geometrical configurations are depicted in Fig. These include:

- Straight stairs (with or without intermediate landing)
- Quarter-turn stairs
- Dog-legged stairs
- Open well stairs
- Spiral stairs
- Helicoidal stairs



(a) straight stairs

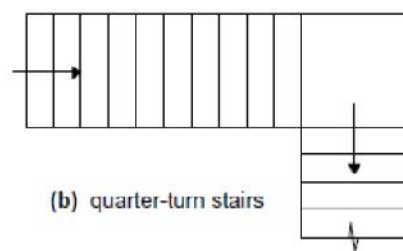

(b) quarter-turn stairs

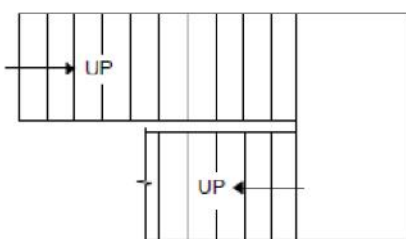

(c) dog-legged stairs

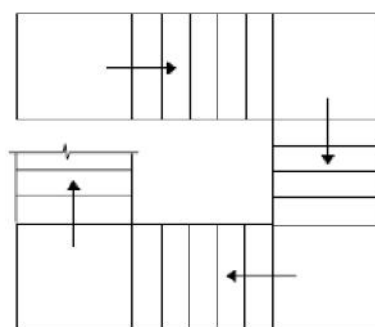

(d) open-well stairs



#### 4.1.4 Structural Classification

Structurally, staircases may be classified largely into two categories, depending on the predominant direction in which the slab component of the stair undergoes flexure:

1. Stair slab spanning transversely (stair widthwise);
2. Stair slab spanning longitudinally (along the incline).

##### Stair Slab Spanning Transversely

The slab component of the stair (whether comprising an isolated tread slab, a tread-riser unit or a waist slab) is supported on its side(s) or cantilevers laterally from a central support. The slab supports gravity loads by bending essentially in a *transverse vertical plane*, with the span along the *width* of the stair.

In the case of the cantilevered slabs, it is economical to provide isolated treads (without risers). However, the tread-riser type of arrangement and the waist slab type are also sometimes employed in practice, as cantilevers. The spandrel beam is subjected to torsion (equilibrium torsion'), in addition to flexure and shear.

When the slab is supported at the two sides by means of 'stringer beams' or masonry walls, it may be designed as simply supported, but reinforcement at the top should be provided near the supports to resist the 'negative' moments that may arise on account of possible partial fixity.

##### Stair Slab Spanning Longitudinally

In this case, the supports to the stair slab are provided parallel to the riser at two or more locations, causing the slab to bend longitudinally between the supports. It may be noted that longitudinal bending can occur in configurations other than the straight stair configuration, such as quarter-turn stairs, dog-legged stairs, open well stairs and helicoidal stairs.

The slab arrangement may either be the conventional waist slab type or the tread-riser type. The slab thickness depends on the 'effective span', which should be taken as the centre-to-centre distance between the beam/wall supports, according to the Code (Cl. 33.1a, c). In certain situations, beam or wall supports may not be available parallel to the riser at the landing. Instead, the flight is supported between the landings, which span transversely, parallel to the risers. In such cases, the Code (Cl. 33.1b) specifies that the effective span for

the flight (spanning longitudinally) should be taken as the going of the stairs plus at each end either half the width of the landing or one metre, whichever is smaller.

#### 4.1.5 Numerical Problem

Design a (waist slab type) dog-legged staircase for an office building, given the following data:

- Height between floor = 3.2 m;
- Riser = 160 mm, tread = 270 mm;
- Width of flight = landing width = 1.25 m
- Live load = 5.0 kN/m
- Finishes load = 0.6 kN/m

Assume the stairs to be supported on 230 mm thick masonry walls at the outer edges of the landing, parallel to the risers [Fig. 12.13(a)]. Use M 20 concrete and Fe 415 steel. Assume mild exposure conditions.

Solution

Given:  $R = 160 \text{ mm}$ ,  $T = 270 \text{ mm} \Rightarrow +RT22$

= 314 mm Effective span = c/c distance between supports = 5.16 m [Fig below].

- Assume a waist slab thickness  $\approx l/20 = 5160/20 = 258 \rightarrow 260 \text{ mm}$ .

Assuming 20 mm clear cover (*mild* exposure) and 12  $\phi$  main bars, effective depth  $d = 260 - 20 - 12/2 = 234 \text{ mm}$ .

The slab thickness in the landing regions may be taken as 200 mm, as the bending moments are relatively low here.

*Loads on going* [fig. below] on projected plan area:

(1) self-weight of waist slab @ $25 \times 0.26 \times 314/270$	$= 7.56 \text{ kN/m}^2$
(2) self-weight of steps @ $25 \times (0.5 \times 0.16)$	$= 2.00 \text{ kN/m}^2$
(3) finishes (given)	$= 0.60 \text{ kN/m}^2$
(4) live load (given)	$= 5.00 \text{ kN/m}^2$
Total	$= 15.16 \text{ kN/m}^2$

$\Rightarrow$  Factored load =  $15.16 \times 1.5 = 22.74 \text{ kN/m}^2$

- *Loads on landing*

(1) self-weight of slab @ $25 \times 0.20$	$= 5.00 \text{ kN/m}^2$
(2) finishes	@ $0.6 \text{ kN/m}^2$
(3) live loads	@ $5.0 \text{ kN/m}^2$
Total	$= 10.60 \text{ kN/m}^2$

$$\Rightarrow \text{Factored load} = 10.60 \times 1.5 = 15.90 \text{ kN/m}^2$$

- *Design Moment* [Fig. below]

$$\text{Reaction } R = (15.90 \times 1.365) + (22.74 \times 2.43) / 2 = 49.33 \text{ kN/m}$$

Maximum moment at midspan:

$$\begin{aligned} M_u &= (49.33 \times 2.58) - (15.90 \times 1.365) \times (2.58 - 1.365/2) \\ &\quad - (22.74) \times (2.58 - 1.365)^2 / 2 \\ &= 69.30 \text{ kNm/m} \end{aligned}$$

$$R = \frac{M_u}{bd^2} = 1.265 \text{ MPa}$$

Assuming  $f_{ck} = 20 \text{ MPa}$ ,  $f_y = 415 \text{ MPa}$ ,

$$\frac{p_t}{100} = \frac{A_{st}}{100} = 0.381 \times 10^{-2}$$

$$\Rightarrow (A_{st})_{req} = (0.381 \times 10^{-2}) \times 10^3 \times 234 = 892 \text{ mm}^2$$

Required spacing of 12  $\phi$  bars = 127 mm

Required spacing of 16  $\phi$  bars = 225 mm

**Provide 16  $\phi$  @ 220c/c**

- *Distributors*

$$(A_{st})_{req} = 0.0012bt = 312 \text{ mm}^2 / \text{m}$$

spacing 10  $\phi$  bars = 251 mm

**Provide 10  $\phi$  @ 250c/c as distributors.**

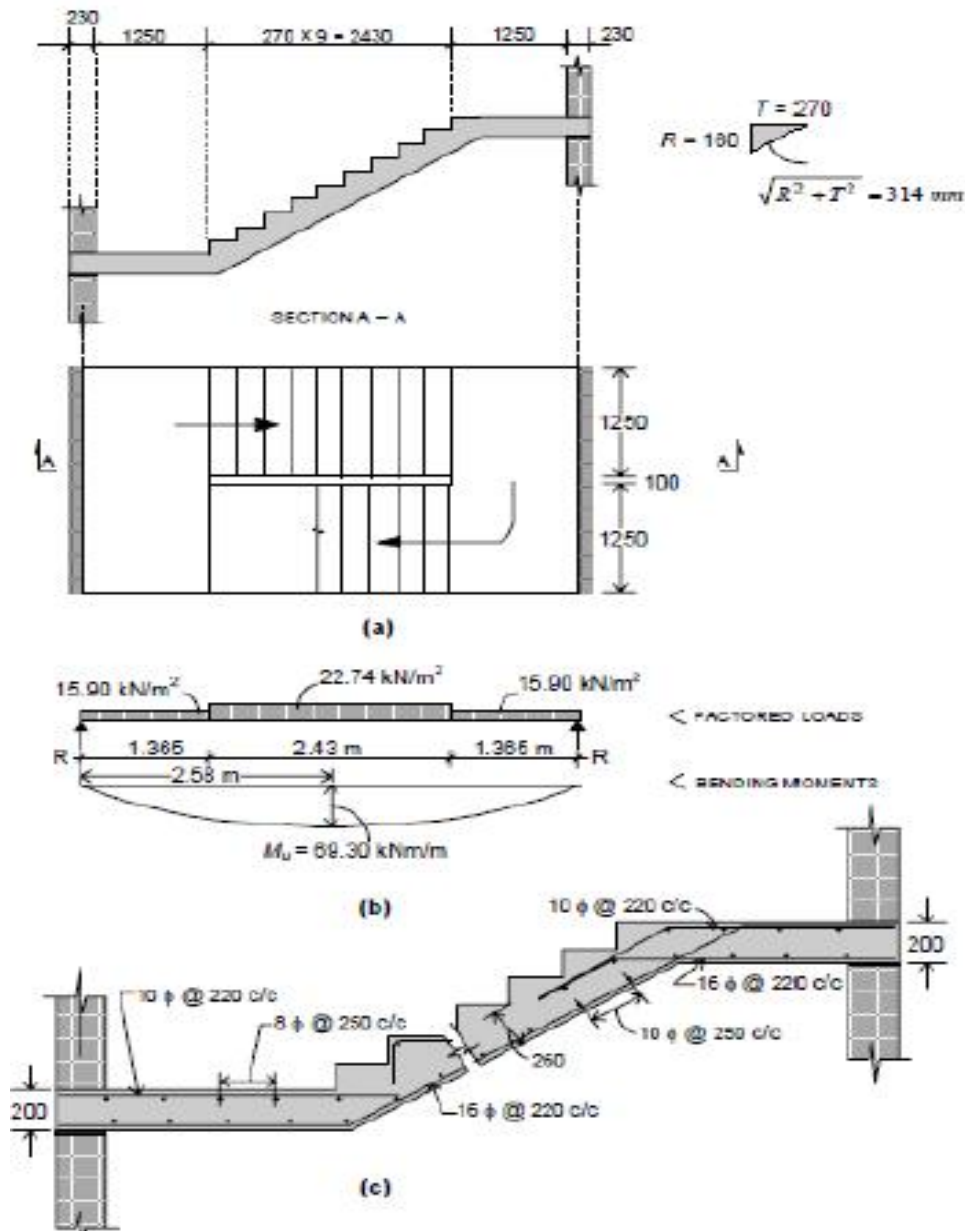

**4.1.6 Outcome**

1. Able to design the dog-legged and open newel staircase

**4.1.7 Assignment Questions**

Design a dog legged stair case for a residential building hall measuring 2.2m x 4.7 m. The width of the landing is 1m. The distance between floor to floor is 3.3 m. The rise and tread may be taken as 150mm and 270mm respectively. The weight of floor finish is 1 kN/m<sup>2</sup>. The materials used are M20 grade concrete and Fe415 grade steel. Sketch the details of steel. Here flight and the landing slabs spans in the same direction i.e, Flight spans longitudinally.

**4.1.8 Future Study**

<https://nptel.ac.in/courses/105105104/pdf/m9120.pdf>

## Slabs

4.2.1 Introduction

4.2.2 Objective

4.2.3 Classification of Slabs

4.2.4 Method of analysis

4.2.5 General guidelines

4.2.6 Behavior of one-way slab

4.2.7 Behavior of two-way slab

4.2.8 Types of two-way slabs

4.2.9 Design example

4.2.10 Outcomes

4.2.11 Assignment question

4.2.12 Future study



### 4.2.1 Introduction to Slabs

A slab is a flat two dimensional planar structural element having thickness small compared to its other two dimensions. It provides a working flat surface or a covering shelter in buildings. It primarily transfer the load by bending in one or two directions. Reinforced concrete slabs are used in floors, roofs and walls of buildings and as the decks of bridges. The floor system of a structure can take many forms such as in situ solid slab, ribbed slab or pre-cast units. Slabs may be supported on monolithic concrete beam, steel beams, walls or directly over the columns. Concrete slab behave primarily as flexural members and the design is similar to that of beams.

### 4.2.2 Objective

1. To design one-way and two-way slabs

### 4.2.3 CLASSIFICATION OF SLABS

Slabs are classified based on many aspects

- 1) **Based of shape:** Square, rectangular, circular and polygonal in shape.
- 2) **Based on type of support:** Slab supported on walls, Slab supported on beams, Slab supported on columns (Flat slabs).
- 3) **Based on support or boundary condition:** Simply supported, Cantilever slab, Overhanging slab, Fixed or Continues slab.
- 4) **Based on use:** Roof slab, Floor slab, Foundation slab, Water tank slab.
- 5) **Basis of cross section or sectional configuration:** Ribbed slab /Grid slab, Solid slab, Filler slab, Folded plate
- 6) **Basis of spanning directions:**

One way slab – Spanning in one direction

Two way slab - Spanning in two direction

### 4.2.4 METHODS OF ANALYSIS

The analysis of slabs is extremely complicated because of the influence of number of factors stated above. Thus the exact (close form) solutions are not easily available. The various methods are:

- a) Classical methods – Levy and Naviers solutions (Plate analysis)
- b) Yield line analysis – Used for ultimate /limit analysis
- c) Numerical techniques – Finite element and Finite difference method.
- d) Semi empirical – Prescribed by codes for practical design which uses coefficients.

### 4.2.5 GENERAL GUIDELINES

**a. Effective span of slab :**

Effective span of slab shall be lesser of the two

1.  $l = \text{clear span} + d$  (effective depth )
2.  $l = \text{Center to center distance between the support}$

**b. Depth of slab:**

The depth of slab depends on bending moment and deflection criterion. the trail depth can be obtained using:

- Effective depth  $d = \text{Span} / ((l/d)_{\text{Basic}} \times \text{modification factor})$
- For obtaining modification factor, the percentage of steel for slab can be assumed from 0.2 to 0.5%
- The effective depth  $d$  of two way slabs can also be assumed using cl.24.1, IS 456

Type of support	Fe-250	Fe-415
Simply supported	1/35	1/28
continuous	1/40	1/32

OR

The following thumb rules can be used

- One way slab  $d = (1/22)$  to  $(1/28)$ .
- Two way simply supported slab  $d = (1/20)$  to  $(1/30)$
- Two way restrained slab  $d = (1/30)$  to  $(1/32)$

**c. Load on slab:**

The load on slab comprises of Dead load, floor finish and live load. The loads are calculated per unit area (load/m<sup>2</sup>).

Dead load =  $D \times 25$  kN/m<sup>2</sup> (Where  $D$  is thickness of slab in m)

Floor finish (Assumed as) = 1 to 2 kN/m<sup>2</sup>

Live load (Assumed as) = 3 to 5 kN/m<sup>2</sup> (depending on the occupancy of the building)

**DETAILING REQUIREMENTS AS PER IS 456: 2000****a. Nominal Cover:**

For Mild exposure – 20 mm

For Moderate exposure – 30 mm

However, if the diameter of bar do not exceed 12 mm, or cover may be reduced by 5 mm.

Thus for main reinforcement up to 12 mm diameter bar and for mild exposure, the nominal cover is 15 mm

b. **Minimum reinforcement** : The reinforcement in either direction in slab shall not be less than

- 0.15% of the total cross sectional area for Fe-250 steel
- 0.12% of the total cross sectional area for Fe-415 & Fe-500 steel.

c. **Spacing of bars**: The maximum spacing of bars shall not exceed

- Main Steel –  $3d$  or 300 mm whichever is smaller
- Distribution steel –  $5d$  or 450 mm whichever is smaller

Note: The minimum clear spacing of bars is not kept less than 75 mm (Preferably 100 mm) though code do not recommend any value.

d. **Maximum diameter of bar**: The maximum diameter of bar in slab, shall not exceed  $D/8$ , where  $D$  is the total thickness of slab.

#### 4.2.6 BEHAVIOR OF ONE WAY SLAB

When a slab is supported only on two parallel opposite edges, it spans only in the direction perpendicular to two supporting edges. Such a slab is called one way slab. Also, if the slab is supported on all four edges and the ratio of longer span ( $l_y$ ) to shorter span ( $l_x$ ) i.e  $l_y/l_x > 2$ , practically the slab spans across the shorter span. Such a slabs are also designed as one way slabs. In this case, the main reinforcement is provided along the spanning direction to resist one way bending.

#### 4.2.7 BEHAVIOR OF TWO WAY SLABS

A rectangular slab supported on four edge supports, which bends in two orthogonal directions and deflects in the form of dish or a saucer is called two way slabs. For a two way slab the ratio of  $l_y/l_x$  shall be  $\leq 2.0$ .

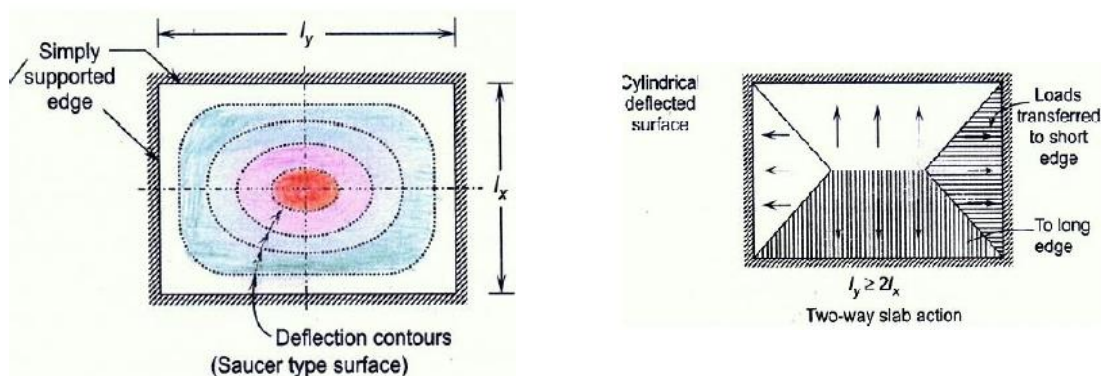

Since, the slab rest freely on all sides, due to transverse load the corners tend to curl up and lift up. The slab loses the contact over some region. This is known as lifting of corner. These slabs are called two way simply supported slabs. If the slabs are cast monolithic with the beams, the corners of the slab are restrained from lifting. These slabs are called restrained

slabs. At corner, the rotation occurs in both the direction and causes the corners to lift. If the corners of slab are restrained from lifting, downward reaction results at corner & the end strips gets restrained against rotation. However, when the ends are restrained and the rotation of central strip still occurs and causing rotation at corner (slab is acting as unit) the end strip is subjected to torsion.

#### **4.2.8 Types of Two Way Slab**

Two way slabs are classified into two types based on the support conditions:

- a) Simply supported slab
- b) Restrained slabs

##### **Two way simply supported slabs**

The bending moments  $M_x$  and  $M_y$  for a rectangular slabs simply supported on all four edges with corners free to lift or the slabs do not having adequate provisions to prevent lifting of corners are obtained using

$$M_x = \alpha_x W l_x$$

$$M_y = \alpha_y W l_x$$

Where,  $\alpha_x$  and  $\alpha_y$  are coefficients given in Table 1 (Table 27,IS 456-2000)

W- Total load /unit area

$l_x$  &  $l_y$  – lengths of shorter and longer span.

##### **Two way restrained slabs**

When the two way slabs are supported on beam or when the corners of the slabs are prevented from lifting the bending moment coefficients are obtained from Table 2 (Table 26, IS456-2000) depending on the type of panel shown in Fig. 3. These coefficients are obtained using yield line theory. Since, the slabs are restrained; negative moment arises near the supports. The bending moments are obtained using;

$$M_x \text{ (Negative)} = \alpha_x^{(-)} W l_x^2$$

$$M_x \text{ (Positive)} = \alpha_x^{(+)} W l_x^2$$

$$M_y \text{ (Negative)} = \alpha_y^{(-)} W l_x^2$$

$$M_y \text{ (Positive)} = \alpha_y^{(+)} W l_x^2$$

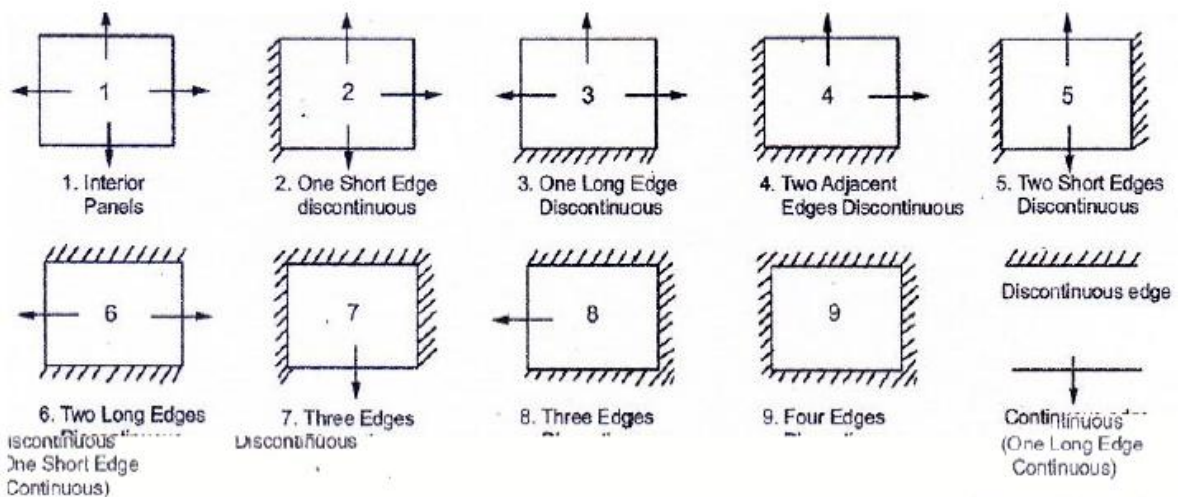

**ONE WAY CONTINUOUS SLAB**

The slabs spanning in one direction and continuous over supports are called one way continuous slabs. These are idealised as continuous beam of unit width. For slabs of uniform section which support substantially UDL over three or more spans which do not differ by more than 15% of the longest, the B.M and S.F are obtained using the coefficients available in Table 12 and Table 13 of IS 456-2000. For moments at supports where two unequal spans meet or in case where the slabs are not equally loaded, the average of the two values for the negative moments at supports may be taken. Alternatively, the moments may be obtained by moment distribution or any other methods.

**4.2.9 DESIGN EXAMPLES**

1. Design a simply supported one –way slab over a clear span of 3.5 m. It carries a live load of 4 kN/m<sup>2</sup> and floor finish of 1.5 kN/m<sup>2</sup>. The width of supporting wall is 230 mm. Adopt M- 20 concrete & Fe-415 steel.

**1) Trail depth and effective span**

Assume approximate depth  $d = L/26$

$$3500/26 = 134 \text{ mm}$$

Assume overall depth  $D=160 \text{ mm}$  & clear cover  $15\text{mm}$  for mild exposure

$$d = 160 - 15 (\text{cover}) - 10/2 (\text{dia of Bar}/2) = 140 \text{ mm}$$

Effective span is lesser of the two

- i.  $l = 3.5 + 0.23$  (width of support) = 3.73 m
  - ii.  $l = 3.5 + 0.14$  (effective depth) = 3.64 m
- effective span = 3.64 m

**2) Load on slab**

- i. Self weight of slab =  $0.16 \times 25 = 4.00$
  - ii. Floor finish = 1.50
  - iii. Live load = 4.00
- = 9.5 kN/m<sup>2</sup>

Ultimate load  $W_u = 9.5 \times 1.5 = 14.25 \text{ kN/m}^2$

**3) Design bending moment and check for depth**

$$M_u = W_u l^2 / 8 = \frac{14.25 \times 3.64^2}{8} = 23.60 \text{ kN/m}$$

Minimum depth required from BM consideration

$$d = \frac{\sqrt{M_u}}{0.130 f_{ck} b} = \frac{\sqrt{23.60 \times 10^6}}{0.138 \times 20 \times 1000} = 92.4 > 140 \text{ (OK)}$$

**4) Area of Reinforcement**

Area of steel is obtained using the following equation

$$M_u = 0.87 f_y A_{st} d \left( 1 - \frac{f_y A_{st}}{f_{ck} b d} \right)$$

$$23.60 \times 10^6 = 0.87 \times 415 \times A_{st} \times 140 \left( 1 - \frac{415 \times A_{st}}{20 \times 1000 \times 140} \right)$$

$$23.60 \times 10^6 = 50547 A_{st} - 749 A_{st}^2$$

Solving  $A_{st} = 504 \text{ mm}^2$

OR

$$A_{st} = \frac{0.5 f_{ck}}{f_y} \left[ 1 - \sqrt{1 - \frac{4.6 M_u}{f_{ck} b d^2}} \right] b d$$

$$A_{st} = \frac{0.5 \times 20}{415} \left[ 1 - \sqrt{1 - \frac{4.6 \times 23.60 \times 10^6}{20 \times 1000 \times 140^2}} \right] 1000 \times 140$$

= 505 mm<sup>2</sup>

Spacing of 10mm  $S_v = \frac{A_{st}}{A_{st}} \times 1000$

$$S_v = \frac{76}{505} \times 1000 = 154 \text{ mm}$$

Provide 10mm @ 150 C/C (< 3d or 300)

(120 or 300)      OK



Provided steel ( $A_{st}=524\text{mm}^2, P_t=0.37\%$ )

Distribution steel @ 0.12% of the Gross area.

$$\frac{0.12}{100} \times 1000 \times 160 = 192 \text{ mm}^2$$

Spacing of 8 mm  $S_v = \frac{50}{192} \times 1000 = 260 \text{ mm}$

Provide 8 mm @ 260 mm C/C (<5d or 450)

(700 or 450) OK

**5) Check for shear**

Design shear  $V_u = W_u l / 2$

$$= 14.25 \times \frac{3.64}{2} = 25.93 \text{ kN}$$

$$\tau_v = \frac{25.93 \times 10^3}{1000 \times 140} = 0.18 \text{ N/mm}^2 \quad (< \tau_{c \text{ max}} = 2.8 \text{ N/mm}^2)$$

Shear resisted by concrete  $\tau_c = 0.42$  for  $p_t = 0.37$  (Table 19, IS 456-2000)

However for solid slab design shear strength shall be

$$= \tau_c k$$

Where, K is obtained from Cl.40.2.1.1, IS 456 -2000

$$\tau_{cd} = 0.42 \times 1.28 = 0.53 \text{ N/mm}^2$$

$$\tau_{cd} > \tau_v \quad \text{OK}$$

**6) Check for deflection**

$$\left(\frac{l}{d}\right)_{\text{Actual}} < \left(\frac{l}{d}\right)_{\text{Allowable}}$$

$$\left(\frac{l}{d}\right)_{\text{Allowable}} = \left(\frac{l}{d}\right)_{\text{Basic}} \times k_1 \times k_2 \times k_3 \times k_4.$$

$k_1$ - Modification factor for tension steel

$k_2$  Modification factor for compression steel

$k_3$  Modification factor for T-sections

$k_4$ -Only

if span exceeds 10 m (10/span)

$$k_1 = 1.38 \text{ for } P_t = 0.37 \text{ (Fig. 4, cl.32.2.1)}$$

$$\left(\frac{l}{d}\right)_{\text{Allowable}} = 20 \times 1.38 = 27.6$$

$$\left(\frac{l}{d}\right)_{\text{Actual}} = 3630 / 140 = 25.92$$

$$\left(\frac{l}{d}\right)_{\text{Actual}} < \left(\frac{l}{d}\right)_{\text{Allowable}} \quad \text{(OK)}$$

7) Check for Development length

Development length

$$L_d = \frac{\phi \sigma_s}{4 \tau_{bd}}$$

$$L_d = (0.87 \times 415 \times 10) / (4 \times 1.2 \times 1.6) = 470 \text{ mm}$$

At simple support, where compressive reaction confines the bars, to limit the dia. of bar

$$L_d \leq 1.3 \left( \frac{M_1}{V} \right) + L_o$$

Since alternate bars are cranked  $M_1 = M_v / 2 = 23.2 / 2 = 11.8 \text{ kN.m}$

$V_1 = 5.93 \text{ kN.}$ , Providing 90° bend and 25 mm end cover

$$L_o = 230 / 2 + 25 + 3(\text{dia of bar}) = 120$$

$$470 < (1.3 \times 11.8 \times 10^6) / (25.9 \times 10^3) + 120 = 711 \text{ mm} \quad \text{O. K.}$$

However, from the end anchorage requirement

extend the bars for a length equal to  $l_d / 3 = 156 \text{ mm}$  from inner face of support

8) Check for cracking

- Steel is more than 0.12% of the gross area.
- Spacing of steel is < 3d
- Diameter of bar used is < 160/8=20mm

Check for cracking is satisfied.

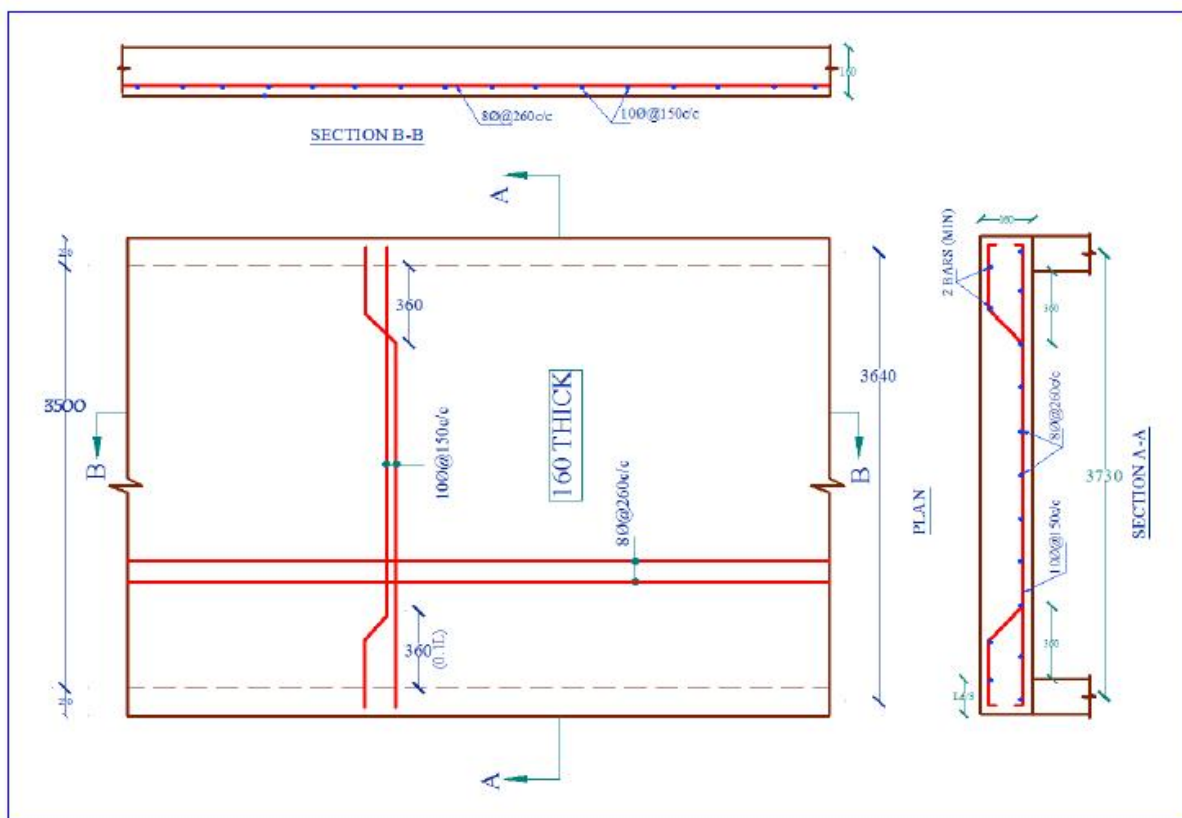

Reinforcement Detail of One way slab



## 4.2.10 Outcome

1. Able to design one-way and two-way slab

## 4.2.11 Assignment questions

1. Design a R.C Slab for a room measuring 6.5mX5m. The slab is cast monolithically over the beams with corners held down. The width of the supporting beam is 230 mm. The slab carries superimposed load of 4.5kN/m<sup>2</sup>. Use M-20 concrete and Fe-500 Steel.

## 4.2.12 Future Study

<https://nptel.ac.in/courses/105105104/pdf/m8119.pdf>