

Module – 5

Columns

- 5.1.1 Introduction**
- 5.1.2 Objective**
- 5.1.3 Definitions**
- 5.1.4 Classification of columns**
- 5.1.5 Longitudinal reinforcement**
- 5.1.6 Transverse reinforcement**
- 5.1.7 Problems**
- 5.1.8 Outcome**
- 5.1.9 Assignment questions**
- 5.1.10 Future study**

5.1.1 Introduction

Compression members are structural elements primarily subjected to axial compressive forces and hence, their design is guided by considerations of strength and buckling. Examples of compression member pedestal, column, wall and strut.

5.1.2 Objective

To design the RCC rectangular and circular columns as per the codal provisions

5.1.3 Definitions

(a) Effective length: The vertical distance between the points of inflection of the compression member in the buckled configuration in a plane is termed as effective length l_e of that compression member in that plane. The effective length is different from the unsupported length l of the member, though it depends on the unsupported length and the type of end restraints. The relation between the effective and unsupported lengths of any compression member is $l_e = k l$ (1) Where k is the ratio of effective to the unsupported lengths. Clause 25.2 of IS 456 stipulates the effective lengths of compression members (vide Annex E of IS 456). This parameter is needed in classifying and designing the compression members.

(b) Pedestal: Pedestal is a vertical compression member whose effective length l_e does not exceed three times of its least horizontal dimension b (cl. 26.5.3.1h, Note). The other horizontal dimension D shall not exceed four times of b .

(c) Column: Column is a vertical compression member whose unsupported length l shall not exceed sixty times of b (least lateral dimension), if restrained at the two ends. Further, its unsupported length of a cantilever column shall not exceed $100b/D$, where D is the larger lateral dimension which is also restricted up to four times of b (vide cl. 25.3 of IS 456).

(d) Wall: Wall is a vertical compression member whose effective height H_{we} to thickness t (least lateral dimension) shall not exceed 30 (cl. 32.2.3 of IS 456). The larger horizontal dimension i.e., the length of the wall L is more than $4t$.

5.1.4 Classification of Columns

Based on Types of Reinforcement

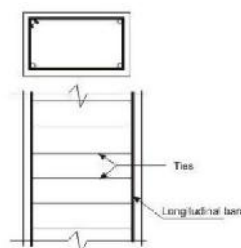

Figure 3.1(a) Tied Column

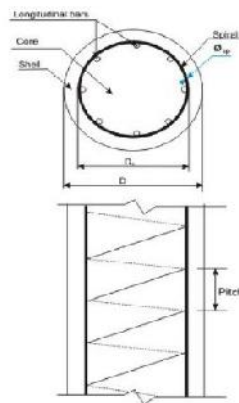

Figure 3.1(b) Column with helical reinforcement

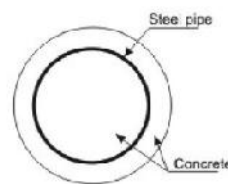

Figure 3.1(d) Composite column (steel pipe)

Figure 3.1 Tied, helically bound and composite columns

Based on the types of reinforcement, the reinforced concrete columns are classified into three groups:

- (i) Tied columns: The main longitudinal reinforcement bars are enclosed within closely spaced lateral ties (Fig.3.1a).
- (ii) Columns with helical reinforcement: The main longitudinal reinforcement bars are enclosed within closely spaced and continuously wound spiral reinforcement. Circular and octagonal columns are mostly of this type (Fig. 3.1b).
- (iii) Composite columns: The main longitudinal reinforcement of the composite columns consists of structural steel sections or pipes with or without longitudinal bars (Fig. 3.1c and d).

Out of the three types of columns, the tied columns are mostly common with different shapes of the cross-sections viz. square, rectangular etc. Helically bound columns are also used for circular or octagonal shapes of cross-sections.

Based on Loadings

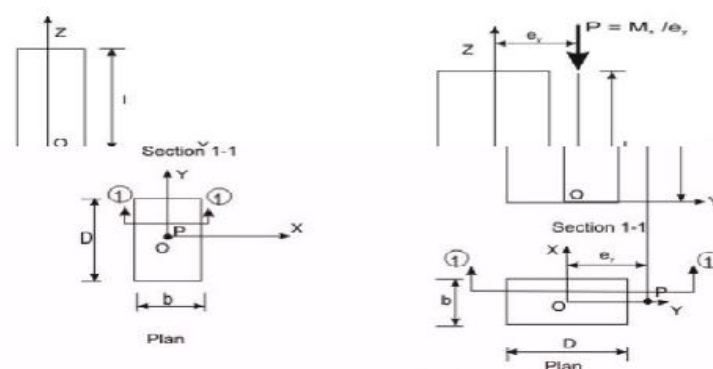

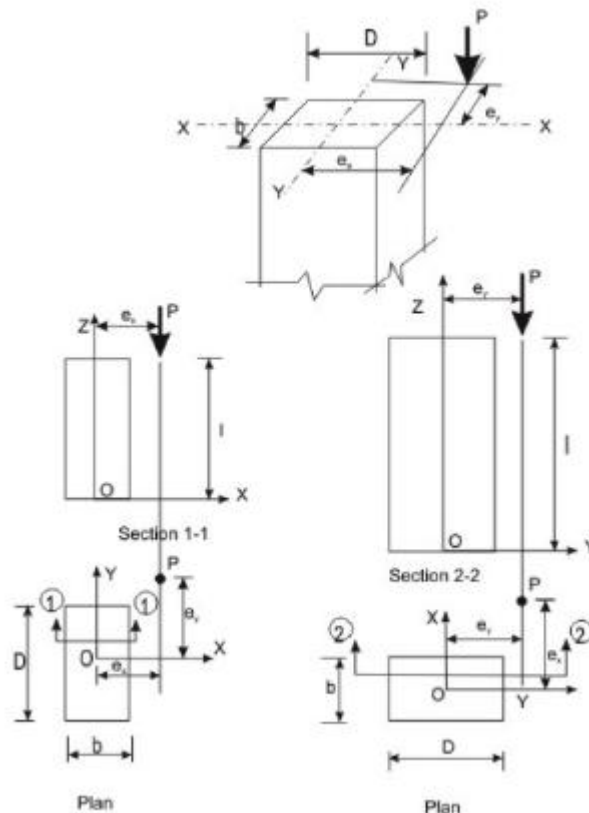

Columns are classified into the three following types based on the loadings:

- (i) Columns subjected to axial loads only (concentric), as shown in Fig. 3.2a.
- (ii) Columns subjected to combined axial load and uniaxial bending, as shown in Fig. 3.2b.
- (iii) Columns subjected to combined axial load and bi-axial bending, as shown in Fig. 3.2c.

Based on Slenderness Ratios

Columns are classified into the following two types based on the slenderness ratios:

- (i) Short columns
- (ii) Slender or long columns

The slenderness ratio of steel column is the ratio of its effective length l_e to its least radius of gyration r . In case of reinforced concrete column, however, IS 456 stipulates the slenderness ratio as the ratio of its effective length l_e to its least lateral dimension. As mentioned earlier in sec. 3.1(a), the effective length l_e is different from the unsupported length, the rectangular reinforced concrete column of cross-sectional dimensions b and D shall have two effective lengths in the two directions of b and D . Accordingly, the column may have the possibility of buckling depending on the two values of slenderness ratios as given below:

Slenderness ratio about the major axis = l_{ex}/D

Slenderness ratio about the minor axis = l_{ey}/b

Based on the discussion above, cl. 25.1.2 of IS 456 stipulates the following:

A compression member may be considered as short when both the slenderness ratios l_{ex}/D and l_{ey}/b are less than 12 where l_{ex} = effective length in respect of the major axis, D = depth in respect of the major axis, l_{ey} = effective length in respect of the minor axis, and b = width of the member. It shall otherwise be considered as a slender compression member.

Further, it is essential to avoid the mode 3 type of failure of columns so that all columns should have material failure (modes 1 and 2) only. Accordingly, cl. 25.3.1 of IS 456 stipulates the maximum unsupported length between two restraints of a column to sixty times its least lateral dimension. For cantilever columns, when one end of the column is unrestrained, the unsupported length is restricted to $100b/D$ where b and D are as defined earlier.

5.1.5 Longitudinal Reinforcement

The longitudinal reinforcing bars carry the compressive loads along with the concrete. Clause 26.5.3.1 stipulates the guidelines regarding the minimum and maximum amount, number of bars, minimum diameter of bars, spacing of bars etc. The following are the salient points:

- (a) The minimum amount of steel should be at least 0.8 per cent of the gross cross-sectional area of the column required if for any reason the provided area is more than the required area.
- (b) The maximum amount of steel should be 4 per cent of the gross cross-sectional area of the column so that it does not exceed 6 per cent when bars from column below have to be lapped with those in the column under consideration.
- (c) Four and six are the minimum number of longitudinal bars in rectangular and circular columns, respectively.
- (d) The diameter of the longitudinal bars should be at least 12 mm.
- (e) Columns having helical reinforcement shall have at least six longitudinal bars within and in contact with the helical reinforcement. The bars shall be placed equidistant around its inner circumference.
- (f) The bars shall be spaced not exceeding 300 mm along the periphery of the column.
- (g) The amount of reinforcement for pedestal shall be at least 0.15 per cent of the cross sectional area provided.

5.1.6 Transverse Reinforcement

Transverse reinforcing bars are provided in forms of circular rings, polygonal links (lateral ties) with internal angles not exceeding 135° or helical reinforcement. The transverse reinforcing bars are provided to ensure that every longitudinal bar nearest to the compression

face has effective lateral support against buckling. Clause 26.5.3.2 stipulates the guidelines of the arrangement of transverse reinforcement. The salient points are:

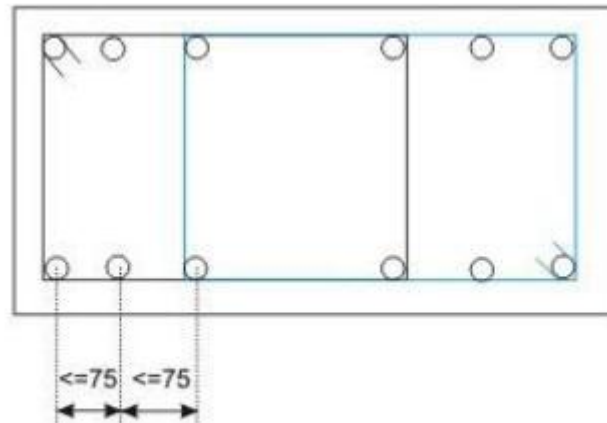

Figure 3.4 Lateral tie (Arrangement 1)

Pitch and Diameter of Lateral Ties

(a) Pitch: The maximum pitch of transverse reinforcement shall be the least of the following:

- (i) The least lateral dimension of the compression members;
- (ii) Sixteen times the smallest diameter of the longitudinal reinforcement bar to be tied; and
- (iii) 300 mm.

(b) Diameter: The diameter of the polygonal links or lateral ties shall be not less than one fourth of the diameter of the largest longitudinal bar, and in no case less than 6 mm.

5.1.7 Assumptions in the Design of Compression Members by Limit State of Collapse

The following are the assumptions in addition to given in 38.1 (a) to (e) for flexure for the design of compression members (cl. 39.1 of IS 456).

- (i) The maximum compressive strain in concrete in axial compression is taken as 0.002.
- (ii) The maximum compressive strain at the highly compressed extreme fibre in concrete subjected to axial compression and bending and when there is no tension on the section shall be 0.0035 minus 0.75 times the strain at the least compressed extreme fibre.

Minimum Eccentricity

In practical construction, columns are rarely truly concentric. Even a theoretical column loaded axially will have accidental eccentricity due to inaccuracy in construction or variation of materials etc. Accordingly, all axially loaded columns should be designed considering the minimum eccentricity as stipulated in cl. 25.4 of IS 456 and given below (Fig.3.2c)

$e_{x \min}$ greater of $(l/500 + D/30)$ or 20 mm

$e_{y \min}$ greater of $(l/500 + b/30)$ or 20 mm where l , D and b are the unsupported length, larger lateral dimension and least lateral dimension, respectively.

Governing Equation for Short Axially Loaded Tied Columns

Factored concentric load applied on short tied columns is resisted by concrete of area A_c and longitudinal steel of areas A_{sc} effectively held by lateral ties at intervals. Assuming the design strengths of concrete and steel are $0.4f_{ck}$ and $0.67f_y$, respectively, we can write

$$P_u = 0.4f_{ck}A_c + 0.67f_yA_{sc}$$

Where P_u = factored axial load on the member,

f_{ck} = characteristic compressive strength of the concrete,

A_c = area of concrete,

f_y = characteristic strength of the compression reinforcement, and

A_{sc} = area of longitudinal reinforcement for columns.

The above equation, given in cl. 39.3 of IS 456, has two unknowns A_c and A_{sc} to be determined from one equation. The equation is recast in terms of A_g , the gross area of concrete and p , the percentage of compression reinforcement employing

$$A_{sc} = pA_g/100$$

$$A_c = A_g(1 - p/100)$$

Accordingly, we can write

$$P_u/A_g = 0.4f_{ck} + (p/100)(0.67f_y - 0.4f_{ck})$$

Equation 4 can be used for direct computation of A_g when P_u , f_{ck} and f_y are known by assuming p ranging from 0.8 to 4 as the minimum and maximum percentages of longitudinal reinforcement. Equation 10.4 also can be employed to determine A_g and p in a similar manner by assuming p .

5.1.7 Numerical Problem

Design the reinforcement in a column of size 400 mm x 600 mm subjected to an axial load of 2000 kN under service dead load and live load. The column has an unsupported length of 4.0 m and effectively held in position and restrained against rotation in both ends. Use M 25 concrete and Fe 415 steel.

Solution**Step 1: To check if the column is short or slender**

Given $l = 4000$ mm, $b = 400$ mm and $D = 600$ mm. Table 28 of IS 456 = $l_{ex} = l_{ey} = 0.65(l) =$

2600 mm. So, we have

$$l_{ex} / D = 2600/600 = 4.33 < 12$$

$$l_{ey} / b = 2600/400 = 6.5 < 12$$

Hence, it is a short column.

Step 2: Minimum eccentricity

$$e_{x \min} = \text{Greater of } (l_{ex} / 500 + D/30) \text{ and } 20 \text{ mm} = 25.2 \text{ mm}$$

$$e_{y \min} = \text{Greater of } (l_{ey} / 500 + b/30) \text{ and } 20 \text{ mm} = 20 \text{ mm}$$

$$0.05 D = 0.05(600) = 30 \text{ mm} > 25.2 \text{ mm} (= e_{x \min})$$

$$0.05 b = 0.05(400) = 20 \text{ mm} = 20 \text{ mm} (= e_{y \min})$$

Hence, the equation given in cl.39.3 of IS 456 (Eq.(1)) is applicable for the design here.

Step 3: Area of steel

Fro Eq.10.4, we have

$$P_u = 0.4 f_{ck} A_c + 0.67 f_y A_{sc}$$

$$3000(10^3) = 0.4(25) \{(400)(600) - A_{sc}\} + 0.67(415) A_{sc}$$

which gives,

$$A_{sc} = 2238.39 \text{ mm}^2$$

Provide 6-20 mm diameter and 2-16 mm diameter rods giving $2287 \text{ mm}^2 (> 2238.39 \text{ mm}^2)$ and $p = 0.953$ per cent, which is more than minimum percentage of 0.8 and less than maximum percentage of 4.0. Hence, o.k.

Step 4: Lateral ties

The diameter of transverse reinforcement (lateral ties) is determined from cl.26.5.3.2 C-2 of IS 456 as not less than (i) $d/4$ and (ii) 6 mm. Here, d = largest bar diameter used as longitudinal reinforcement = 20 mm. So, the diameter of bars used as lateral ties = 6 mm.

The pitch of lateral ties, as per cl.26.5.3.2 C-1 of IS 456, should be not more than the least of

(i) The least lateral dimension of the column = 400 mm

(ii) Sixteen times the smallest diameter of longitudinal reinforcement bar to be tied = $16(16) = 256$ mm

(iii) 300 mm

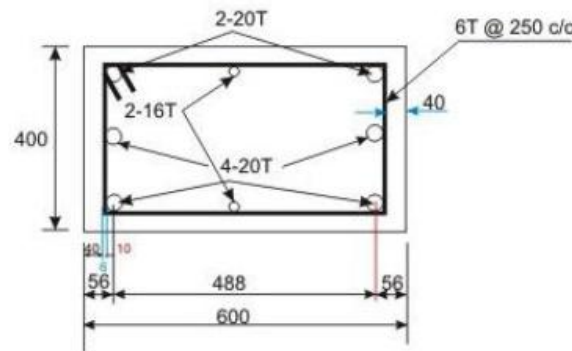

Reinforcement Detailing

IS 456 recommends the following simplified method, based on Bresler's formulation, for the design of biaxially loaded columns. The relationship between M_{uxz} and M_{uyz} for a particular value of $P_u = P_{uz}$, expressed in non-dimensional form is:

$$(M_{ux} / M_{ux1})^{\alpha^n} + (M_{uy} / M_{uy1})^{\alpha^n} \leq 1 \tag{5}$$

where M_{ux} and M_{uy} = moments about x and y axes due to design loads, and

α^n is related to P_u / P_{uz} ,

where

$$\begin{aligned} P_{uz} &= 0.45 f_{ck} A_c + 0.75 f_y A_{sc} \\ &= 0.45 A_g + (0.75 f_y - 0.45 f_{ck}) A_{sc} \end{aligned} \tag{6}$$

where A_g = gross area of the section, and

A_{sc} = total area of steel in the section

M_{uxz} , M_{uyz} , M_{ux1} and M_{uy1} are explained earlier.

$$\alpha^n = 1.0, \text{ when } P_u / P_{uz} \leq 0.2$$

$$\alpha^n = 0.67 + 1.67 \frac{P_u}{P_{uz}}, \text{ when } 0.2 < (P_u / P_{uz}) < 0.8 \tag{7}$$

$$\alpha^n = 2.0, \text{ when } (P_u / P_{uz}) \geq 0.8$$

5.1.8 Outcome

1. Able to design the RCC columns

5.1.9 Assignment questions

Design the reinforcement to be provided in the short column is subjected to $P_u = 2000$ kN,

$M_{ux} = 130$ kNm (about the major principal axis) and $M_{uy} = 120$ kNm (about the minor principal axis). The unsupported length of the column is 3.2 m, width $b = 400$ mm and depth $D = 500$ mm. Use M 25 and Fe 415 for the design.

5.1.10 Future Study

<https://nptel.ac.in/courses/105105105/>