

15EE553 Estimating and Costing

V Semester

15EE553: ESTIMATION AND COSTING

SUBJECT CODE	:	15EE553	IA Marks	:	20
No. of Lecture Hrs./ Week	:	03	Exam Hours	:	03
Total No. of Lecture Hrs.	:	40	Exam Marks	:	80

15EE553 Estimating and Costing

Module 1

Principles of Estimation: Introduction to Estimation and Costing, Electrical Schedule, Catalogues, Market Survey and Source Selection, Recording of Estimates, Determination of Required Quantity of Material, Labour Conditions, Determination of Cost Material and Labour, Contingencies, Overhead Charges, Profit, Purchase System, Purchase Enquiry and Selection of Appropriate Purchase Mode, Comparative Statement, Purchase Orders, Payment Of Bills, Tender Form, General Idea about IE Rule, Indian Electricity(IE) Act and IE Rules - 29,30,45,46,47,50,51,54,55,77 and79

8 Hours

Module 2

Wiring: Introduction, Distribution of energy in a Building, PVC Casing and Capping, Conduit Wiring, Desirabilities of Wiring. Types of cables used in Internal Wiring, Multi Strand Cables, Voltage Grading and Specification of Cables

Wiring (continued): Main Switch and Distribution Board, Conduits and its accessories and Fittings. Lighting Accessories and Fittings, Types of Fuses, Size of Fuse, Fuse Modules, Earthing Conductor.

Internal Wiring: General rules for wiring, Design of Lighting Points (Refer to Seventh Chapter of the Textbook), Number of Points, Determination of Total Load, Number of Sub –Circuits, Ratings Main Switch and Distribution Board and Size of Conductor. Current Density, Layout.

8 Hours

Module 3

Service Mains: Introduction, Types, Estimation of Underground and Overhead Service Connections.

Design and Estimation of Power Circuits: Introduction, Important Considerations Regarding Motor Installation Wiring, Input Power, Input Current to Motors, Rating of Cables, Rating of Fuse, Size of Condit, Distribution Board Main Switch and Starter.

8 Hours

Module 4

Estimation of Overhead Transmission and Distribution Lines: (Review of Line Supports, Conductor Materials, Size of Conductor for Overhead Transmission Line, Types of Insulators) [No Question Shall be Set From the Review Portion].

Cross Arms, Pole Brackets and Clamps, Guys and Stays, Conductors Configuration Spacing and Clearances, Span Lengths, Lightning Arrestors, Phase Plates, Danger Plates, Anti Climbing Devices, Bird Guards, Beads of Jumpers, Muffs, Points to be Considered at the Time of Erection of Overhead Lines, Erection of Supports, Setting of Stays, Fixing of Cross Arms, Fixing of Insulators, Conductor Erection.

15EE553 Estimating and Costing

Estimation of Overhead Transmission and Distribution Lines (continued): Repairing and Jointing of Conductors, Dead End Clamps, Positioning of Conductors and Attachment to Insulators, Jumpers, Tee-Offs, Earthing of Transmission Lines, Guarding of Overhead Lines, Clearances of Conductor From Ground, Spacing Between Conductors, Important Specifications.

8 Hours

Module 5

Estimation of Substations: Main Electrical connection, Graphical Symbols for Various Types of Apparatus and Circuit Elements on Substation main Connection Diagram, Single Line Diagram of Typical Substations, Equipment for Substation, Substation Auxiliaries Supply, Substation Earthing.

8 Hours

TEXT BOOK:

1. **Electrical Installation Estimating & Costing**, J.B.Gupta, VIII Edition S.K. Katria & Sons New Delhi

REFERENCE BOOKS:

1. **Electrical Design Estimating and Costing**, K.B.Raina S.K.Bhattacharya, New Age International
2. **Electrical Wiring Estimating and Costing**, Uppal, Khanna Publishers Delhi
3. **I.E.Rules and Act Manuals**

15EE553 Estimating and Costing

Module - 1

- ❖ **PRINCIPLES OF ESTIMATION:** Introduction to estimation & costing, Electrical Schedule, Catalogues
- ❖ Market Survey and source selection, Recording of estimates, Determination of required quantity of material, Labor conditions
- ❖ Determination of cost material and labour, Contingencies, Overhead charges, Profit, Purchase system, Purchase enquiry and selection of appropriate purchase mode, Comparative statement, Purchase orders
- ❖ Payment of bills, Tender form, General idea about IE rule, Indian Electricity Act and major applicable I.E rules.

Introduction to estimation and costing

Electrical estimating is a process used by electricians, construction managers and engineers to determine the amount and cost of electricity required for a specific location or process. There are two general methods of creating accurate electrical estimates: computer software or manual calculations. Both methods have value, benefits and risks. Original electrical estimating software options were quite clumsy to use, but recent enhancements have vastly improved this tool for electrical estimation.

Electrical estimating computer software has increased in popularity as it has improved in quality and performance. This tool is designed for use by electricians, architects and electrical engineers. There are different versions available for residential, commercial or prototype development.

An estimating technique is an approach to predicting cost or revenue. Using a consistent methodology is important to achieve reliable and comparable results. Firms may have specific policies their personnel have to follow when making estimates to ensure that the approach will be similar no matter who prepares the estimate. This can help reduce problems associated with variances in methodology, like an offer from one mechanic in a shop of a very low price for service while another indicates the cost of a job will be much higher.

When preparing estimates, people can broadly divide them into detailed and approximate types.

15EE553 Estimating and Costing

Approximate estimates offer a rough guess of the cost, based on similar projects, experience, and quick research. They can be helpful for getting a general idea of expenses before proceeding with a more detailed estimate. For people soliciting estimates, they can't be quoted as firm bids, but may provide a frame of reference. A homeowner looking for a new roof, for example, could ask for an approximate estimate from several contractors to learn more about the range of possible prices.

Importance of Quality Cost Estimates The reliability of project cost estimates at every stage in the project development process is necessary for responsible fiscal management. Unreliable cost estimates result in severe problems in programming, budgeting, and planning. This, in turn, affects Engineering Services relations with the other divisions within Public Works & Utilities, other agencies, and the public, and ultimately results in loss of credibility.

Prepare Reasonable Cost Estimates Project cost estimating is not an exact science; however, estimators are expected to prepare reasonable project cost estimates that represent the cost to complete the project. These costs include those required not only for the contractor to construct the project but, also includes the costs for the purchase of right of way, mitigation of environmental issues and any other costs that will be incurred to complete the project.

Project alternatives and their associated cost estimates must be thoroughly compiled by diligently using all of the available data, modifying that data with good judgment and using past cost estimating experience so that the cost estimates can be used with confidence. Coordination between the project planning cost estimates, the project design cost estimates, and the specifications and policies that will be in place during the construction of the project is required.

Cost Estimates are Not Static Cost estimates, in a sense, are never completed. They are not static, but have to be reviewed continually to keep them current. The Project Manager (PM) is responsible for keeping the project cost estimate up-to-date throughout the project development process, reviewing all project cost estimates and ensuring that the current project cost estimates are entered into the Project Management data base and a hard copy is in the project file.

Electrical Schedule:

The electrical load schedule is an estimate of the instantaneous electrical loads operating in a facility, in terms of active, reactive and apparent power (measured in kW, kVAR and kVA

15EE553 Estimating and Costing

respectively). The load schedule is usually categorized by switchboard or occasionally by sub-facility / area.

Catalogues:

The main objective of a catalogue is to promote the products and services offered by your company. A catalogue layout properly designed must show your company's products or services arranged neatly, so that they can be easily recognized; and, at the same time, it must look attractive to improve your sales. In addition, the catalogue layout must be strategically arranged in order to give more importance to certain items or to make the catalogue look more eye-catching. Finally, the visual coherence on which a company's corporate Image is supported must be kept. A catalogue may promote products within promotional packages or lithe known products; it may inform the audience about the new comfort and convenience of a service or it can simply contain small businesses' month offers.

Market Survey and source selection:

Market research is a continuous process for gathering data on product characteristics, suppliers' capabilities and the business practices that surround them—plus the analysis of that data to make acquisition decisions. This requires one to collect and analyze information about the market that subsequently can be used to determine whether the need can be met by products or services available in the commercial market; whether commercial practices regaining customizing, modifying products or tailoring services are available to meet customer needs; what are the customary terms and conditions, including warranty, buyer financing, and discounts under which commercial sales are made; and whether the distribution and logistics support capabilities of potential suppliers are sufficient to meet the needs of the government. Marret research information can be used to shape the acquisition strategy, to determine the type and content of the product description or statement of work, to develop the support strategy, the terms and conditions included in the contract, and the evaluation factors used for source selection.

Various locational difficulties are described:

1. Remoteness

15EE553 Estimating and Costing

2. Confined sites
3. Labor availability
4. Weather
5. Design considerations (related to location).
6. Vandalism and site security

Remoteness

A remote construction site, for example, a project site located high in the Blue Ridge Mountains of Virginia, poses a contracting organization with a difficult set of problems to cope with.

Communication Problems

If adequate communications such as telephone are not available, then a radio or cellular-type installation is required. A telephone is a requisite to any construction project: lack of communication during the construction process can result in major, costly errors. In addition, because the project location is further away from the head office, additional long-distance telephone charges will be incurred.

Transportation Problems

All material and labor must be transported to the building site. If the transport route is poor (if, indeed, any route exists at all), then delays in material deliveries may occur; large vehicles may damage narrow bridges or other items of property, whose replacements costs must be borne by the contractor.

It may be necessary for the contractor to widen the existing route or construct a bridge to allow material trailers access into the job site. The route that is proposed should be studied carefully by the estimator. Existing capacity of existing bridges on route should be established to verify if equipment loads can be accommodated or if the bridge needs to be strengthened by the contractor. Finally, the cost of hauling items of equipment to the job site increases as the

15EE553 Estimating and Costing

distance increases. Given these considerations, the requirement for management to make the correct equipment selections becomes very important.

Profit:

Estimating the cost of labor for electrical construction can vary greatly from project to project, depending on the installation crew's experience and the complexity of the project. Charging an hourly installation rate is common for electrical contractors until installation data (number of hours per installer for job completion) can be collected and projects can be estimated based on the amount of work.

Electrical contractors are responsible for installing, repairing, and maintaining electrical systems in homes and commercial buildings. Due to the differences in skills and costs between home systems and commercial systems, most companies will focus solely on either residential or commercial work. Fortunately, the process of pricing an electrical job is similar no matter what type of building is involved. For those with a basic understanding of construction and electricity, it is fairly easy to price an electrical job and develop an appropriate estimate.

Purchase System:

A method used by businesses to buy products and/or services. A purchasing system manages the entire acquisition process, from requisition, to purchase order, to product receipt, to payment. Purchasing systems are a key component of effective inventory management in that they monitor existing stock and help companies determine what to buy, how much to buy and when to buy it. A popular purchasing system is based on economic order quantity models.

Purchase enquiry and selection of appropriate purchase mode:

Guidelines on purchasing practices:

These practices are used by Purchasing to promote competition and ensure that all purchases comply with the standard Requirements. The rules vary depending on the dollar value of the transaction, but the principles should be employed whenever funds are to be used.

15EE553 Estimating and Costing

WORKING TOGETHER IN THREE WAYS

1. Purchasing is available to perform the due diligence, complete required paperwork and execute the final contract.
2. Purchasing is available to work in collaboration with our customers on large projects, on specialty projects or complex needs; drawing on our customers experience while adding purchasing value.
3. Our customers may work independently to source their needs and select their supplier in accordance with university policy. Purchasing will execute the final contract, with prior assurance that all university policies have been adhered to.

The following guidelines are included primarily to give our customers a better understanding of the process and to better facilitate communication and collaboration. If you choose to select the supplier and obtain quotes without assistance from Purchasing, this section should serve as a guide or checklist.

When a Strategic Partner exists for the commodity or service being sought it is important and Purchasing strongly recommends their use. Strategic Partners are pre-qualified and choosing to use one will eliminate the time consuming processes of due diligence; selecting suppliers and preparing and evaluation of bids.

SELECTING QUALIFIED SUPPLIERS:

Supplier selection and evaluation is a process that can take considerable time and energy depending on the product or service.

1. The first step in selecting suppliers is often research, particularly if the product or service has not been purchased before. There are a number of tools available for this initial phase
2. Once a list of potential suppliers has been developed, begin evaluating each supplier's capabilities. Obtaining a Dun & Bradstreet financial report ('running a D&B') is a good place to start. However, a D&B contains only publicly available information or information that the supplier chooses to provide. Some D&Bs also include brief profiles of key management personnel and historical information on the company. Another option is to check with local Better Business Bureaus.
3. There are a number of guidelines for supplier selection
 - Find out how long the supplier has been in business.

15EE553 Estimating and Costing

- Find out who are the supplier's primary customers and ask for and check references. • Investigate a supplier's financial stability.
 - Check bank references. • Tour the supplier's facilities, if possible. • Is the supplier really interested in doing business with the University? • Does the supplier use state-of-the art technology?
 - Does the supplier offer an educational discount?
4. These steps should narrow the field to the three suppliers (sometimes more) who will be asked to bid on the particular product or service.

PREPARING AND EVALUATING A BID

Bidding goods and services is important for several reasons. The bidding process:

- allows "comparison shopping" for the best pricing and service
- allows for an informed and objective choice among potential suppliers
- encourages competition among suppliers • provides a standard for comparing price, quality, and service
- provides a list of qualified suppliers for future bids
- provides access to University business for suppliers

The bid process begins with the development of a set of specifications or objectives. The Contract Administrator (CA) in conjunction with the requester must define the requirements exactly. Colleagues, technical personnel, trade manuals, and suppliers may be consulted for assistance in developing specifications. The requirements are then communicated to the selected suppliers by a Request for Quotation (RFQ) or a Request for Proposal (RFP).

The Indian electricity act, 1910

This is an act relating to amend the law relating to the supply and use of electrical energy. It regulate

1. **License:** Grant of licenses; revocation or amendment of licenses; purchase of under takings; annual accounts of licenses.

15EE553 Estimating and Costing

2. Works: provision has to the opening and breaking up of streets, railways and tramways, notice of new works, laying of supply lines, notice of telegraphic authority, overhead lines compensation for damage

3. Supply: Point of supply, powers of licensee to enter premises, restriction on licensees, obligation on licensees to supply energy. Powers of the state governments to give direction to a licensee. Power to control the distribution and consumption of energy. Disconnection of supply to consumers, Meters.

4. Transmission and use of energy by non licensees: Sanctions required by non licensees in certain cases. Control of transmission and use of energy.

5. General protective clauses: protection of railways, aerodromes, canals, docks and piers, protection of telegraphic and electric signal lines, notice of accidents and enquiries, prohibition of connections with earth and power for government to interfere in certain cases of default.

6. Administration and Rules: Advisory boards, appointment of electrical inspectors.

7. Criminal offences and procedure: Theft of energy penalty for maliciously wasting energy or injuring works, penalty for unauthorized supply of energy by non licensees, penalty for illegal or defective supply or non-compliance with order, penalty for interference with meters or licensees works and for improper use of energy, offences by compliance, institution of prosecution.

The electricity (supply) Act 1948:

This act rationalizes the production and supply of electricity and generally provides for taking measures conducive to its development. It enacts

- **The central electricity authority:**

Constitution. Powers to require accounts, statistics and returns, direction of central government to the authority. Power of central government to make rules, powers of authority to make regulations.

15EE553 Estimating and Costing

- **State electricity boards:**

Transmission companies generating companies, state electricity consultative councils and local advisory committees, constitution and composition of state electricity boards, inter state agreement to extend boards jurisdiction to another state, formation, objects, jurisdiction, etc. of transmission companies, generating companies.

Power and duties of state electricity boards, transmission companies, and generating companies. The works and trading procedure of the board, Transmission Company, and the generating company, coordination with the regional electricity board. The boards finance, accounts and audit, miscellaneous items such as effects of other laws, water power concession to be granted only to the board are a generating company, coordination between boards and multipurpose schemes, powers of entry, annual reports statistics and returns arbitration penalties cognizance of offences direction by the state government, provision relating to income tax, members, officers and other employs of the board to be public servants, protection to persons acting under this act, saving of application of act.

The electricity regulatory commission act, 1998:

The act provides for the establishment of the central electricity regulatory commission and state regulatory commission, central and state transmission utilities, framing grid code and grid standards, rationalization of electricity tariff, transport policy regarding subsidies, promotion of efficient and environmentally benign policies and for matters connected with it.

The electricity act, 2003:

The content supersedes and consolidates the provision of the electricity regulatory commission act, 1998, the Indian electricity supply act, 1948 and the electricity act 1910. the act provides for

- National electricity policy and plan
- Promoting competition, trading and developments of electricity markets. Open access and Parallel distribution.,
- De-licensing, setting up and operating new generating stations, captive generation and dedicated transmission lines.
- Licensing transmission, distribution and supply companies.,

15EE553 Estimating and Costing

- Duties of generating, transmission, distribution and supply companies.,
- Directions of generating, transmission, and distribution and supply companies.,
- Compulsory consumer metering.,
- Reorganization of state electricity boards.
- Rationalizing subsidies.
- Constitution and functions of the central electricity authority.
- Constitution and functions of central and state regulatory commissions, appointment of advisory committees.
- Works. Consumer protection: standard of performance.
- special courts dispute resolutions
- Tariff regulations.
- Offences and penalties for theft of electricity, electric lines and materials, wasting electricity extinguishing public lamps.
- Protection of railways, high ways, aero drums, canals, docks, wharfs and piers.
- Telegraphic, telephone and electric signaling lines.
- Notice of accidents and enquiries.
- Appointment of electrical inspectors. Others and miscellaneous provisions.

Energy conservation act 2001:

This act concerns any form of energy derived from fossil fuels, nuclear substances or materials and hydroelectricity and includes electrical energy or electricity generated from renewable sources of energy or biomass connected to the grid it delineates.

- The establishment and incorporation of the bureau of energy efficiency.
- Transfer of assets, liabilities, etc., of the energy management center.
- Power and function of the bureau.
- Power of the central government to facilitate and impress the efficient use of energy and its conservation.
- Power of the state government to facilitate and impress the efficient use of energy and its conservation.

15EE553 Estimating and Costing

- Finance, accounts and audit of the bureau., and Penalties and adjudication

The Indian electricity rules 1956

As per section 37 of Indian electricity act, 1910. The central electricity board has framed the Indian electricity rules. 1956. It contains 143 rules along with detailed annexure and covers:

- Authorization to form duties.
- Inspection of electric Installations: creation of inspection agency., entry and inspection., inspection fees., appeal against an order ., submission of records by supplier or owner
- Licensing :application, contents and form of draft license., advertisement of application and contents thereof approval of draft license and a notification for grant of licence. Commencement of license., amendment of license preparation and submission of accounts and model condition of supply.
- General safety precautions regarding,construction,installation,protection operation and maintenance of electric supply lines and apparatus., service lines and apparatus on consumers premises., identification of earthed conductors,accessbality of bare conductors ., provisions applicable to protective equipment instructions for restoration of persons suffering from electric shock., intimation of accidents precautions to be adopted by consumers, owners electrical contactors ,electrical work man and suppliers ., periodical inspection testing of consumers installations.
- General conditions relating to supply and use of energy: Testing of consumer's installation. Precaution against leakage. Declined voltage and frequency of supply pacing and sealing of energy and demand meters. Point of supply. Precautions against failure of supply. Electric supply lines ,system and apparatus for low,medium,high and extra high voltage: Testing of insulation resistance .,connection with earth., voltage test systems.,approval by inspector., general conditions has to transformation, use and control of energy., pole type substations discharge of capacitors., supply to neonsigns. Supply of x ray high frequency installations.
- Overhead lines: Materials and strength.,joints.,clearances and supports erection of or alterations of buildings structures conditions to apply where telecommunication lines and power

15EE553 Estimating and Costing

lines can be carried on the same supports., lines crossing ,service lines protection against lightning ., unused overhead lines.

- Electric traction: Additional rules for electric traction. Voltage of supply. Difference of potential on return. Current density in rails. Size and strength of trolley wires records.
- Additional precautions for mines and oil fields.
- Miscellaneous provisions :Rules relaxation by the government ,relaxation by the inspector., supply and use of energy by non licenses and others penalty for breaking seal and other penalties for breach of rules repeal.

MODULE – 2

RESIDENTIAL BUILDING ELECTRIFICATION:

General rules guidelines for wiring of residential installation and positioning of equipment's:

1. Every installation is to be properly protected near the point of entry of supply cables by 2-linked main switch and a fuse Module.
2. Conductor used is to be of such a size that it carry load current safely.
3. Every sub-circuit is to be connected to a distribution fuse board.
4. A switch board is to be installed so that its bottom lies 1.25mts above the floor.
5. All plugs & socket outlets are of 3-pin type
6. All incandescent lamps are to be hung at ht of 2.5mt above the floor
7. No fuse or switch is to be provided in earthed conductor
8. In any building , light, fan power wiring are to be kept separately.
9. Unless otherwise specified, the clearance between the bottom most point of the ceiling fan and the floor shall be not less than 2.4 m. the minimum clearance between the ceiling and the plane of the blade shall be not less than 30 cm.
10. Each 15 A socket outlet provided in building for the use of domestic appliances such as AC, water cooler etc.
11. Each socket outlet shall be controlled by a switch which shall preferably be located immediately adjacent thereto or combined therewith.
12. Ordinary socket outlet may be fixed at any convenient place at a height above 20 cm from

15EE553 Estimating and Costing

the floor level. In a situation where the socket outlet is accessible to children, socket outlet which automatically gets screened by the withdrawal of plug is preferable.

Principles of circuit design in lighting and power circuits

Recommended levels of illumination

Location	Illumination Level
Entrance Hallways	100
Living room	300
Dining room	150
Bed room	
General	300
Dress table, bed heads	200
Games or recreation room	100
Table games	300
Kitchen	200
Kitchen sink	300
Laundry	200
Bath room	100
Bath room mirror	300
Sewing	700
workshop	200
stairs	100
Garage	70
Study	300

Procedures for designing the circuits and deciding the number of circuits

- Balancing of circuit in 3 phase installation shall be planned before hand. It is recommended that all socket outlets in a room are connected to one phase.

15EE553 Estimating and Costing

- Power sub-circuits shall be kept separate and distinct from light and fan sub-circuit. All

15EE553 Estimating and Costing

wiring shall be on the distribution system with main and branch distribution boards convenient physical and electrical load centers.

- It is recommended to provide at least two lighting sub-circuits in each house. Separate lighting circuits be utilized for all external lightings of steps, walkways, porch, car park terrace etc. with two way switch control.
- Whatever the load to be fed is more than 1 kW, it shall be controlled by an isolator switch or MCB
- Switch boards shall not be erected above gas stove or sink or within 2.5 m of any washing Module in the washing room.
- A switch board shall not be installed at height less than 1.25 m from floor level, unless the front of the switch board is completely enclosed by a door.
- Energy meters shall be installed at a height where it is convenient to note the meter reading; it should preferably not be installed at a height not less than 1 m from the ground.

Selection of type of wiring and rating of wires and cables

Conduit wiring :

- Rigid non-metallic conduits are used for surface, recessed and concealed conduit wiring. Conductors of ac supply and dc supply shall be bunched in separate conduits. The numbers of insulated cables that may be drawn into the conduit are given in table.

Maximum permissible number of 1.1 kV grade single core cables that may be drawn into rigid non metallic conduits Conduit shall be fixed by saddles secured to suitable wood plugs or other plugs with screws at an interval of not more than 60 cm. whenever necessary, bends or diversions may be achieved by bending the conduits or by employing normal bends, inspection bends, inspection boxes, elbows or similar fittings.

Size of cable		Size of conduit (mm)					
Normal cross sectional area (Sq. mm)	Number and diameter (in mm) of wires	16	20	25	32	40	50
		Number of cables, maximum					

15EE553 Estimating and Costing

1	1/1.12	5	7	13	20	-	-
1.5	1/1.40	4	6	10	14	-	-
2.5	3/1.06	3	5	10	14	-	-
4	7/0.85	2	3	6	10	14	-
6	7/1.40	-	2	5	9	11	-
10	7/1.40	-	-	4	7	9	-
16	7/1.70	-	-	2	4	5	12
25	7/2.24	-	-	-	2	2	6
35	7/2.50	-	-	-	-	2	5
50	19/1.80	-	-	-	-	2	3

Load calculations and selection of size of conductor

Size of conductors		Two cables dc or Single phase		Three or four cables balanced three	
Normal area (mm ²)	No. and dia. of wire (mm)	Current rating (A)	ac Approx. length of run for one volt drop (m)	Current rating (A)	ac Approx. length of run for one volt drop (m)
1	1/1.12	5	3	3	3.7
1.5	3/0.737	10	3.4	10	4.3
2.5	3/1.06	15	3.7	13	4.8
4	7/.737	20	4.0	15	5.2
6	7/1.06	28	4.9	25	6.1
8	7/1.12	36	5.5	32	7.0
10	7/1.40	43		39	

Selection of rating of main switch, distribution board

List of standard Iron Clad main switches for domestic purpose:

- a) DPIC (Double Pole Iron Clad) main switch: 5, 15 or 30 A, 250V or DPMCB (Double Pole Miniature Circuit Breaker): 5, 10, 16, 32 and 63 A, 250 V
- b) TPIC (Triple Pole Iron Clad) main switch: 30, 60, 100, 200 A, 500 V or TPMCB (Triple Pole Miniature Circuit Breaker): 16, 32 and 63 A, 500 V, beyond this TPMCCB (Triple Pole Molded Case Circuit Breaker): 100, 200, 300 and 500 A, 660 V
- c) TPN main switch: 30, 60, 100, 200, 300 A, 500 V or TPNMCB: 16, 32, 63A, 500 V, beyond this TPNMCCB: 100, 200, 300, 500 A, 660 V.

15EE553 Estimating and Costing

Selection of Main Distribution Board: The Main Distribution Board is a fuse box or MCB box where different sub-circuits are terminated. Numbers of sub-circuits are decided based on the total connected load or total number of points.

Protective switchgear ELCB and MCB and wiring accessories

- There shall be circuit breaker or a linked switch with fuse on each live conductor of the supply mains at the point of entry. The main switch shall be easily accessible and shall be situated near to the termination of service line.
- Branch distribution board shall be provided with a fuse or a miniature circuit breaker (MCB) or both of adequate rating / setting.
- Light and fans may be wired on a common circuit. Such sub-circuit shall not have more than a total of 10 points of light, fan and 5 A socket outlets. The load of such circuit shall be restricted to 800 Watts. Power sub-circuit shall be designed according to the load but in no case shall there be more than two 15 A outlets on each sub-circuit.
- The load on any low voltage sub circuit shall not exceed 3000 Watts. In case of new installation, all circuits and sub-circuits shall be designed by making a provision of 20% increase in load due to any future modification.
- The distribution fuse board shall be located as near as possible to the centre of the load. These shall be fixed in suitable stanchion or wall and shall not be more than 2 m from the floor level.
- All conductors shall be of copper or aluminium. Conductor for final sub-circuit of fan and light wiring shall have a nominal cross sectional area not less than 1 Sq. mm copper and 1.5 Sq. mm aluminium. The cross sectional area for power wiring shall be not less than 2.5 Sq. mm copper, 4 Sq. mm aluminium. The minimum cross sectional area of conductors of flexible cord shall be 0.5 Sq. mm copper.

Earthing of residential Installation

Earthing or grounding means connecting all parts of the apparatus (other than live part) to the general mass of earth by wire of negligible resistance. This ensures that all parts of the equipment other than live part shall be at earth potential (ie, zero potential) so that the operator shall be at earth potential at all the time, thus will avoid shock to the operator. The neutral of the supply system is also solidly earthed to ensure its potential equal to zero.

Earthing shall generally be carried out in accordance with the requirement of Indian Electricity Rule 1956, particularly IE Rules 32, 51, 61, 62, 67, 69, 88(2) and 90.

- All medium voltage equipment shall be earthed two separate and distinct connections

15EE553 Estimating and Costing

with earth through an earth electrode. In the case of high and extra high voltage the neutral point shall be earthed by not less than two separate and distinct connections.

- Each earth system shall be so devised that the testing of individual earth electrode is possible. It is recommended that the value of any earth system resistance shall not be more than 5Ω , unless otherwise specified.
- Under ordinary conditions of soil, use of copper, iron or mild steel electrodes is recommended. In direct current system, however due to corrosive action, it is recommended to use only copper electrode. Use similar materials for earth electrode and earth conductors to avoid corrosion.

Sequence to be followed for preparing estimate

Sequence to be followed in carrying out the estimate are:

1. Wiring layout: Prepare building plan on a suitable scale and mark electrical points, switch boards, main board, meter board, distribution board etc. on the plan using specified symbols. The path of wiring showing connection to each point is marked by a little thick line.
2. Calculation of total connected load: The total connected load and hence the total current is calculated for deciding the cable size, rating of main switch board and distribution board.
3. Selection of Main Switch: Once the connected load is calculated, the main switch can be conveniently selected from the available standard switch list.

List of standard Iron Clad main switches for domestic purpose:

- d) DPIC (Double Pole Iron Clad) main switch: 5,15 or 30 A, 250V or DPMCB (Double Pole Miniature Circuit Breaker): 5, 10, 16, 32 and 63 A, 250 V
- e) TPIC (Triple Pole Iron Clad) main switch: 30, 60, 100, 200 A, 500 V or TPMCB (Triple Pole Miniature Circuit Breaker): 16, 32 and 63 A, 500 V, beyond this TPMCCB (Triple Pole Molded Case Circuit Breaker): 100, 200, 300 and 500 A, 660 V
- f) TPN main switch: 30, 60, 100, 200, 300 A, 500 V or TPNMCB: 16, 32, 63A, 500 V, beyond this TPNMCCB: 100, 200, 300, 500 A, 660 V.

15EE553 Estimating and Costing

4. Selection of Main Distribution Board: The Main Distribution Board is a fuse box or MCB box where different sub-circuits are terminated. Numbers of sub-circuits are decided based on the total connected load or total number of points.
5. Assumptions: the conditions which are not specified in the question may be assumed conveniently. Eg:- location of main switch board, switch boards, height of building(if not specified)
6. Calculation of length of conduit: To avoid duplicity in calculating the length of conduit pipe, this may be calculated in three stages.
 - (a) The conduit installed from switch board up to horizontal run (HR) including from main switch or DB to HR.
 - (b) The conduit on walls running parallel to the floor ie, the HR below ceiling.
 - (c) The conduit installed between HR and ceiling, along ceiling & ceiling to last point on HR.

The total length of conduit is calculated by adding the length of conduit obtained from the three stages and including 10% wastage.
7. Calculation of length of phase wire and neutral wire: The phase wire and neutral wire is calculated sub-circuit wise. Once it is calculated, wastage of 15% is included.
8. Calculation of length of earth wire: The earth wire is run along the conduit. The calculations are carried out in length but it is converted in to weight while preparing material table.
9. Preparing Material Table: The material table should be prepared with complete specification of each item.

Preparation of detailed estimates and costing of residential installation.

Domestic dwellings/ Residential buildings include any buildings in which sleeping accommodation is provided for normal residential purpose with cooking and dining facilities.

(1) Estimation of load requirements

- The electrical installation in this area mainly consists of lights, fans, electrical appliances and other gadgets. In estimating the current to be carried, following ratings are recommended.

15EE553 Estimating and Costing

Item	Recommended Rating
Incandescent lamps	60 W
Ceiling Fan and Table Fan	60 W
5 A, 3 pin socket outlet	100 W
Fluorescent tubes:	
Power socket outlet (15 A)	1000 W
For Geyser	2000 W
For AC	3000 W

(2) Number of points in branch circuit :

Recommended numbers of points for dwelling Modules are as follows

Sl No.	Description	Area of the main dwelling Module in m ²				
		35	45	55	85	140
1	Light point	7	8	10	12	17
2	Ceiling fans	2 points – 2 fans	3-2	4-3	5-4	7-5
3	5 A socket outlet	2	3	4	5	7
4	15 A socket outlet	-	1	2	3	4
5	Call - bell	-	-	1	1	1

(3) Number of socket outlets :

Recommended schedule of socket outlets for various sub-Modules are as follows

Description	Number of socket outlets	
	5 A	15 A
Bed room	2 to 3	1
Living room	2 to 3	2
Kitchen	1	2
Dining room	2	1
Garage	1	1
For refrigerator	-	1
For air conditioner	-	1
Verandah	1 per 10 m ²	1
Bathroom	1	1

ELECTRIFICATION OF COMMERCIAL INSTALLATION:

Differentiate between electrification of residential and commercial installation

Fundamental considerations for planning of an electrical installation system for commercial building

Reception and Distribution of Main Supply

- There shall be circuit breaker or a linked switch with fuse on each live conductor of the supply mains at the point of entry. The main switch shall be easily accessible and shall be situated near to the termination of service line.
- Branch distribution board shall be provided with a fuse or a miniature circuit breaker (MCB) or both of adequate rating / setting.
- Light and fans may be wired on a common circuit. Such sub-circuit shall not have more than a total of 10 points of light, fan and 5 A socket outlets. The load of such circuit shall be restricted to 800 Watts. Power sub-circuit shall be designed according to the load but in no case shall there be more than two 15 A outlets on each sub-circuit.
- The load on any low voltage sub circuit shall not exceed 3000 Watts. In case of new installation, all circuits and sub-circuits shall be designed by making a provision of 20% increase in load due to any future modification.
- The distribution fuse board shall be located as near as possible to the centre of the load. These shall be fixed in suitable stanchion or wall and shall not be more than 2 m from the floor level.
- All conductors shall be of copper or aluminium. Conductor for final sub-circuit of fan and light wiring shall have a nominal cross sectional area not less than 1 Sq. mm copper and 1.5 Sq. mm aluminium. The cross sectional area for power wiring shall be not less than 2.5 Sq. mm copper, 4 Sq. mm aluminium. The minimum cross sectional area of conductors of flexible cord shall be 0.5 Sq. mm copper.

Design considerations of electrical installation system for commercial building

Load calculation and selection of size of service connection and nature of supply,

Deciding the size of the cables, busbar and bus bar chambers

Next step is finding Bus bar size.

Bus bar materials are:

- Aluminum or Aluminium alloy – working current density, 0.8 A/ Sq.mm
- Copper – working current density, 1.2 A/ Sq.mm
- For the above set up:-

$$250/0.8 = 312.5 \text{ Sq. mm}$$

For neutral bus bar, half the size of phase bus bar size is sufficient.

ie, 40 x 8 mm or 50 x 6 mm Al bus bar may be used for phases and 20 x 8 mm or 25 x 6 mm for neutral.

Or

31 x 6 mm Cu bus bar may be used for phases and 31 x 3 mm for neutral.

f For small switch boards the distance between the bus supports will be 50 cms.

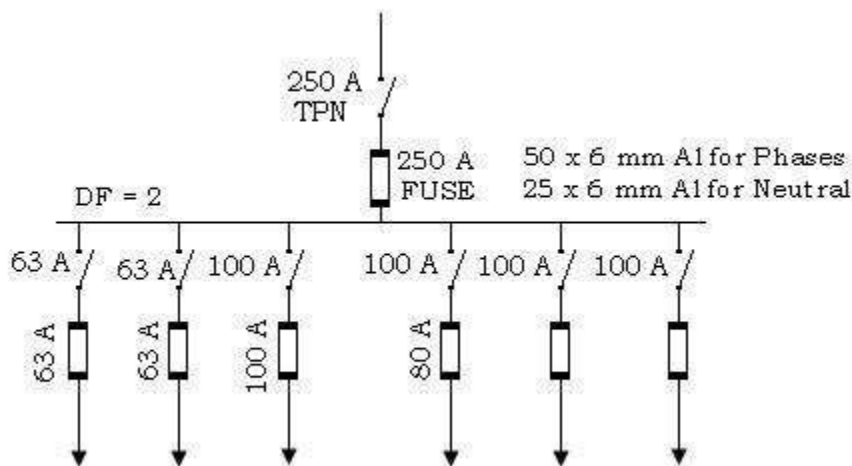

15EE553 Estimating and Costing

- f* If DF is not given, we can assume, DF as 2 for all switch boards.
- f* The term ampacity is some times used to denote the maximum current rating of the feeders. If DF is not clearly known, the total ampacity of outlet feeders shall not be more than two times the ampacity of the incomer feeder.
- f* The feeder cables need to be selected for the fuse used in the SFU.
 - Eg:- when we want 125A feeder, the fuse and cable corresponding to 125A. But the switch may be 200A, since above 100A, only 200A switch is available.
- f* Standard switch ratings are: 32A, 63A, 100A, 200A, 250A, 400A, 630A AND 800A. Some manufactures makes 125A and 320A also.

f **Mounting arrangements and positioning of switchboards, distribution boards main switch etc**

Switch boards in general are power distribution centers with SFUs/MCCBs/ACBs/OCBs for controlling outlets and incomer. Unlike DBs, switch boards are specified by its total current carrying capacity or incomer current rating. Where as in DBs current rating of the outlet is the specified rating. Standard switch board ratings are 100 A, 200 A, 400 A, 800 A, 1200 A, 1600 A, 2000 A, 2500 A and 3200 A. If the incomer supply is controlled with an SFU, the switch board is called switch fuse controlled board and if the incomer is ACB/ OCB controlled, it is called breaker controlled board.

A switch board having three sections

- f* Outlet control gears
- f* Bus chamber
- f* Incomer control gear

The outlet switch, fuse and cable rating are decided by the load that has to be handled through that feeder. If the number of loads is more, SSB is required, which is installed almost at the load centers. In smaller set up SSB may not be necessary and MSB will be the only switch board.

DB / DFB (Distribution Fuse Board) / FDB (Fuse Distribution Board)

Usually even numbers of ways are used in DBs (2, 4, 6, 8, 10 and 12). As per IS the maximum number of ways is limited to 12.

15EE553 Estimating and Costing

Eg- 12 way 3 ph DB = 4 x 12 = 48 cable connection including neutral.

Usual current rating of DB s are : 16A, 32A and 63A

63A, 12 way DB s are not common. Since maximum input current=63 X 12 =700A which is not possible to handle by a DB. Hence 63A DB is 2 ways or 4 ways.

Motor loads up to 20 hp are fed from DB s of various rating.

All DBs have isolator or SFU as incomer switch. But in some case this is avoided if the switch board supplying to the DB is within 3m from the DB

In a designed system 20% spare outlets are kept for future expansion. ie, in each DB, 1 or 2 outlets shall be kept as spares

Earthing of the electrical installation

Design data on earth electrode

Standard earth electrodes are;

- (a) Rod and pipe electrodes, (b) Strip or conductor electrodes, (c) Plate electrodes, and (d) Cable sheaths.

Measurement	Type of Electrodes				
	Rod	Pipe	Strip	Round conductor	Plate
Diameter(not less than)	16 mm (Steel or GI)	38 mm (Steel or GI) 100			

15EE553 Estimating and Costing

	12.5 mm (copper)				
--	---------------------	--	--	--	--

mm

(Cast

15EE553 Estimating and Costing

		Iron)			
Length/ Depth of burial (not less than)	2.5 m (ideal 3 to 3.5 m)	2.5 m	0.5 m	1.5 m	1.5 m
Size	-	-	25 x 1.60 mm (copper) 25 x 4 (Steel or GI)	3.0 Sq. mm (copper) 6 Sq. mm (Steel or GI)	60 x 60 cm
Thickness	-	-	-	-	6.30 mm (copper) 3.15 mm

GI) (Steel

Selection of type wire, wiring system and layout

Selection of rating of incomer isolator/SFU and incomer feeder size :

In any system, all the connected loads will not be put on simultaneously. This reduces the maximum demand from simply computing by adding all connected loads. The maximum demand is expressed through a factor called 'Diversity Factor,

$$\text{Diversity Factor (DF)} = \frac{\text{Sum of connected load}}{\text{Simultaneous max.demand(MD)}} > 1$$

From the requirement data, the details of connected load on each DB are known to us. For spare outlets, an average of other outlets can be assumed.

If the DF is known, we can find the maximum current requirement of the DB to feed all loads

15EE553 Estimating and Costing

including spares. Instead of furnishing the DF, a usual practice is specifying MD. A commonly accepted and safe value of DF is 1.5. this value can be assumed for each DB

If motor loads are connected, for selection of isolator / SFU, the starting current has to be taken in to account rather than continuous current. Eg:- 5 hp - 5Nos and 10 hp - 2Nos motors are connected to a DB

Total connected load = 45hp

MD = $1.5 \times 45 = 67.5$ hp

Corresponding maximum current is $30 \times 1.4 = 42$ A. This current is the continuous maximum current

When motors are started we have to account the starting inrush current of large motor in the down stream. Starting current of DOL starting motor is 2.5 times the rated current and for assisted starting (star delta), it is 1.5 times the rated current.

So the MD calculation in the above case is as follows:

f One 10 hp (one higher rating) kept aside *f* Now only MD of 20 hp is existing

f Its maximum current = $20 \times 1.4 = 28$ A

f For one 10 hp alone, maximum current = $2.5 \times (10 \times 1.4) = 35$

A *f* Therefore MD of the DB = $28 + 35 = 63$ A

f ie, incoming feeder, isolator/SFU of the DB can be rated to 63 A

Sequence to be followed to prepare estimate

The feeder to a DB will be fed from an SSB or MSB. This feeder will be protected by the HRC fuse in the SSB or MSB. It is necessary that the feeder protective fuse should not blow off before the motor protective fuse in the DB. This is achieved by proper grading between the fuses. The fuse of SSB/MSB is denoted as major fuse and that of DB is termed as minor fuse. For achieving grading the ratio between major and minor fuses shall be 2:1 or more

Feeder cable is selected by considering the 20% excess of the MD of DB. Also major fuse rating should match with the cable selection.

If the cable length exceeds 75 to 100mtr, the voltage drop condition should be taken in to account. The voltage drop in the feeder should not be more than 3% in the maximum demand condition.

V Semester

Module 2

Wiring: Introduction, Distribution of energy in a Building, PVC Casing and Capping, Conduit Wiring, Desirabilities of Wiring. Types of cables used in Internal Wiring, Multi Strand Cables, Voltage Grading and Specification of Cables

Wiring (continued): Main Switch and Distribution Board, Conduits and its accessories and Fittings. Lighting Accessories and Fittings, Types of Fuses, Size of Fuse, Fuse Modules, Earthing Conductor.

Internal Wiring: General rules for wiring, Design of Lighting Points (Refer to Seventh Chapter of the Textbook), Number of Points, Determination of Total Load, Number of Sub –Circuits, Ratings Main Switch and Distribution Board and Size of Conductor. Current Density, Layout.

8 H ours

TEXT BOOK:

1. **Electrical Installation Estimating & Costing**, J.B.Gupta, VIII Edition S.K. Katria & Sons New Delhi

REFERENCE BOOKS:

1. **Electrical Design Estimating and Costing**, K.B.Raina S.K.Bhattacharya, New Age International
2. **Electrical Wiring Estimating and Costing**, Uppal, Khanna Publishers Delhi
3. **I.E.Rules and Act Manuals**

MODULE – 2

WIRING

Distribution of energy in a Building - Residential Building Electrification:

General rules guidelines for wiring of residential installation and positioning of equipment's:

1. Every installation is to be properly protected near the point of entry of supply cables by 2-linked main switch and a fuse Module.
2. Conductor used is to be of such a size that it carry load current safely.
3. Every sub-circuit is to be connected to a distribution fuse board.
4. A switch board is to be installed so that its bottom lies 1.25mts above the floor.
5. All plugs & socket outlets are of 3-pin type
6. All incandescent lamps are to be hung at ht of 2.5mt above the floor
7. No fuse or switch is to be provided in earthed conductor
8. In any building , light, fan power wiring are to be kept separately.
9. Unless otherwise specified, the clearance between the bottom most point of the ceiling fan and the floor shall be not less than 2.4 m. the minimum clearance between the ceiling and the plane of the blade shall be not less than 30 cm.
10. Each 15 A socket outlet provided in building for the use of domestic appliances such as AC, water cooler etc.
11. Each socket outlet shall be controlled by a switch which shall preferably be located immediately adjacent thereto or combined therewith.
12. Ordinary socket outlet may be fixed at any convenient place at a height above 20 cm from

the floor level. In a situation where the socket outlet is accessible to children, socket outlet which automatically gets screened by the withdrawal of plug is preferable.

Principles of circuit design in lighting and power circuits

Recommended levels of illumination

Location	Illumination Level
Entrance Hallways	100
Living room	300
Dining room	150
Bed room	
General	300
Dress table, bed heads	200
Games or recreation room	100
Table games	300
Kitchen	200
Kitchen sink	300
Laundry	200
Bath room	100
Bath room mirror	300
Sewing	700
workshop	200
stairs	100
Garage	70
Study	300

Procedures for designing the circuits and deciding the number of circuits

- Balancing of circuit in 3 phase installation shall be planned before hand. It is recommended that all socket outlets in a room are connected to one phase.

- Power sub-circuits shall be kept separate and distinct from light and fan sub-circuit. All wiring shall be on the distribution system with main and branch distribution boards convenient physical and electrical load centers.
- It is recommended to provide at least two lighting sub-circuits in each house. Separate lighting circuits be utilized for all external lightings of steps, walkways, porch, car park terrace etc. with two way switch control.
- Whatever the load to be fed is more than 1 kW, it shall be controlled by an isolator switch or MCB
- Switch boards shall not be erected above gas stove or sink or within 2.5 m of any washing Module in the washing room.
- A switch board shall not be installed at height less than 1.25 m from floor level, unless the front of the switch board is completely enclosed by a door.
- Energy meters shall be installed at a height where it is convenient to note the meter reading; it should preferably not be installed at a height not less than 1 m from the ground.

Selection of type of wiring and rating of wires and cables

Conduit wiring :

- Rigid non-metallic conduits are used for surface, recessed and concealed conduit wiring. Conductors of ac supply and dc supply shall be bunched in separate conduits. The numbers of insulated cables that may be drawn into the conduit are given in table.

Maximum permissible number of 1.1 kV grade single core cables that may be drawn into rigid non metallic conduits Conduit shall be fixed by saddles secured to suitable wood plugs or other plugs with screws at an interval of not more than 60 cm. whenever necessary, bends or diversions may be achieved by bending the conduits or by employing normal bends, inspection bends, inspection boxes, elbows or similar fittings.

Normal cross sectional area (Sq. mm)	Size of cable	Number and diameter (in mm) of wires	Size of conduit (mm)					
			5	7	13	20	-	-
1.5	1/1.12	1/1.40	4	6	10	14	-	-
2.5	3/1.06	3/1.06	16	20	25	32	40	50
4	7/0.85	7/0.85	3	5	10	14	-	-
6	7/1.40	7/1.40	2	3	6	10	14	-
10	7/1.40	7/1.40	-	2	5	9	11	-
16	7/1.70	7/1.70	-	-	4	7	9	-
25	7/2.24	7/2.24	-	-	2	4	5	12
35	7/2.50	7/2.50	-	-	-	2	2	6
50	19/1.80	19/1.80	-	-	-	-	2	5
							2	3

Load calculations and selection of size of conductor

Size of conductors		Two cables dc or Single phase		Three or four cables balanced three phase ac	
Normal area (mm ²)	No. and dia. of wire (mm)	Current rating (A)	Approx. length of run for one volt drop ² (m)	Current rating (A)	Approx. length of run for one volt drop ² (m)
1	1/1.12	5	3	3	3.7
1.5	3/0.737	10	3.4	10	4.3
2.5	3/1.06	15	3.7	13	4.8
4	7/0.737	20	4.0	15	5.2
6	7/1.06	28	4.9	25	6.1
8	7/1.12	36	5.5	32	7.0
10	7/1.40	43		39	

Selection of rating of main switch, distribution board

List of standard Iron Clad main switches for domestic purpose:

- DPIC (Double Pole Iron Clad) main switch: 5, 15 or 30 A, 250V or DPMCB (Double Pole Miniature Circuit Breaker): 5, 10, 16, 32 and 63 A, 250 V
- TPIC (Triple Pole Iron Clad) main switch: 30, 60, 100, 200 A, 500 V or TPMCB (Triple Pole Miniature Circuit Breaker): 16, 32 and 63 A, 500 V, beyond this TPMCCB (Triple Pole Molded Case Circuit Breaker): 100, 200, 300 and 500 A, 660 V
- TPN main switch: 30, 60, 100, 200, 300 A, 500 V or TPNMCB: 16, 32, 63A, 500 V, beyond this TPNMCCB: 100, 200, 300, 500 A, 660 V.

Selection of Main Distribution Board: The Main Distribution Board is a fuse box or MCB box where different sub-circuits are terminated. Numbers of sub-circuits are decided based on the total connected load or total number of points.

Protective switchgear ELCB and MCB and wiring accessories

- There shall be circuit breaker or a linked switch with fuse on each live conductor of the supply mains at the point of entry. The main switch shall be easily accessible and shall be situated near to the termination of service line.
- Branch distribution board shall be provided with a fuse or a miniature circuit breaker (MCB) or both of adequate rating / setting.
- Light and fans may be wired on a common circuit. Such sub-circuit shall not have more than a total of 10 points of light, fan and 5 A socket outlets. The load of such circuit shall be restricted to 800 Watts. Power sub-circuit shall be designed according to the load but in no case shall there be more than two 15 A outlets on each sub-circuit.
- The load on any low voltage sub circuit shall not exceed 3000 Watts. In case of new installation, all circuits and sub-circuits shall be designed by making a provision of 20% increase in load due to any future modification.
- The distribution fuse board shall be located as near as possible to the centre of the load. These shall be fixed in suitable stanchion or wall and shall not be more than 2 m from the floor level.
- All conductors shall be of copper or aluminium. Conductor for final sub-circuit of fan and light wiring shall have a nominal cross sectional area not less than 1 Sq. mm copper and 1.5 Sq. mm aluminium. The cross sectional area for power wiring shall be not less than 2.5 Sq. mm copper, 4 Sq. mm aluminium. The minimum cross sectional area of conductors of flexible cord shall be 0.5 Sq. mm copper.

Earthing of residential Installation

Earthing or grounding means connecting all parts of the apparatus (other than live part) to the general mass of earth by wire of negligible resistance. This ensures that all parts of the equipment other than live part shall be at earth potential (ie, zero potential) so that the operator shall be at earth potential at all the time, thus will avoid shock to the operator. The neutral of the supply system is also solidly earthed to ensure its potential equal to zero.

Earthing shall generally be carried out in accordance with the requirement of Indian Electricity Rule 1956, particularly IE Rules 32, 51, 61, 62, 67, 69, 88(2) and 90.

- All medium voltage equipment shall be earthed two separate and distinct connections

with earth through an earth electrode. In the case of high and extra high voltage the neutral point shall be earthed by not less than two separate and distinct connections.

- Each earth system shall be so devised that the testing of individual earth electrode is possible. It is recommended that the value of any earth system resistance shall not be more than 5Ω , unless otherwise specified.
- Under ordinary conditions of soil, use of copper, iron or mild steel electrodes is recommended. In direct current system, however due to corrosive action, it is recommended to use only copper electrode. Use similar materials for earth electrode and earth conductors to avoid corrosion.

Sequence to be followed for preparing estimate

Sequence to be followed in carrying out the estimate are:

1. Wiring layout: Prepare building plan on a suitable scale and mark electrical points, switch boards, main board, meter board, distribution board etc. on the plan using specified symbols. The path of wiring showing connection to each point is marked by a little thick line.
2. Calculation of total connected load: The total connected load and hence the total current is calculated for deciding the cable size, rating of main switch board and distribution board.
3. Selection of Main Switch: Once the connected load is calculated, the main switch can be conveniently selected from the available standard switch list.

List of standard Iron Clad main switches for domestic purpose:

- d) DPIC (Double Pole Iron Clad) main switch: 5, 15 or 30 A, 250V or DPMCB (Double Pole Miniature Circuit Breaker): 5, 10, 16, 32 and 63 A, 250 V
 - e) TPIC (Triple Pole Iron Clad) main switch: 30, 60, 100, 200 A, 500 V or TPMCB (Triple Pole Miniature Circuit Breaker): 16, 32 and 63 A, 500 V, beyond this TPMCCB (Triple Pole Molded Case Circuit Breaker): 100, 200, 300 and 500 A, 660 V
 - f) TPN main switch: 30, 60, 100, 200, 300 A, 500 V or TPNMCB: 16, 32, 63A, 500 V, beyond this TPNMCCB: 100, 200, 300, 500 A, 660 V.
4. Selection of Main Distribution Board: The Main Distribution Board is a fuse box or MCB box where different sub-circuits are terminated. Numbers of sub-circuits are decided based on the total connected load or total number of points.

5. Assumptions: the conditions which are not specified in the question may be assumed conveniently. Eg:- location of main switch board, switch boards, height of building(if not specified)
6. Calculation of length of conduit: To avoid duplicity in calculating the length of conduit pipe, this may be calculated in three stages.
 - (a) The conduit installed from switch board up to horizontal run (HR) including from main switch or DB to HR.
 - (b) The conduit on walls running parallel to the floor ie, the HR below ceiling.
 - (c) The conduit installed between HR and ceiling, along ceiling & ceiling to last point on HR.

The total length of conduit is calculated by adding the length of conduit obtained from the three stages and including 10% wastage.

7. Calculation of length of phase wire and neutral wire: The phase wire and neutral wire is calculated sub-circuit wise. Once it is calculated, wastage of 15% is included.
8. Calculation of length of earth wire: The earth wire is run along the conduit. The calculations are carried out in length but it is converted in to weight while preparing material table.
9. Preparing Material Table: The material table should be prepared with complete specification of each item.

Preparation of detailed estimates and costing of residential installation.

Domestic dwellings/ Residential buildings include any buildings in which sleeping accommodation is provided for normal residential purpose with cooking and dining facilities.

(1) Estimation of load requirements

- The electrical installation in this area mainly consists of lights, fans, electrical appliances and other gadgets. In estimating the current to be carried, following ratings are recommended.

Item	Recommended Rating
Incandescent lamps	60 W
Ceiling Fan and Table Fan	60 W
5 A, 3 pin socket outlet	100 W
Fluorescent tubes:	
Power socket outlet (15 A)	1000 W
For Geyser	2000 W
For AC	3000 W

(2) Number of points in branch circuit :

Recommended numbers of points for dwelling Modules are as follows

Sl No.	Description	Area of the main dwelling Module in m ²				
		35	45	55	85	140
1	Light point	7	8	10	12	17
2	Ceiling fans	2 points – 2 fans	3-2	4-3	5-4	7-5
3	5 A socket outlet	2	3	4	5	7
4	15 A socket outlet	-	1	2	3	4
5	Call - bell	-	-	1	1	1

(3) Number of socket outlets :

Recommended schedule of socket outlets for various sub-Modules are as follows

Description	Number of socket outlets	
	5 A	15 A
Bed room	2 to 3	1
Living room	2 to 3	2
Kitchen	1	2
Dining room	2	1
Garage	1	1
For refrigerator	-	1
For air conditioner	-	1
Verandah	1 per 10 m ²	1
Bathroom	1	1

MODULE – 2

ELECTRIFICATION OF COMMERCIAL INSTALLATION:

Differentiate between electrification of residential and commercial installation

Fundamental considerations for planning of an electrical installation system for commercial building

Reception and Distribution of Main Supply

- There shall be circuit breaker or a linked switch with fuse on each live conductor of the supply mains at the point of entry. The main switch shall be easily accessible and shall be situated near to the termination of service line.
- Branch distribution board shall be provided with a fuse or a miniature circuit breaker (MCB) or both of adequate rating / setting.
- Light and fans may be wired on a common circuit. Such sub-circuit shall not have more than a total of 10 points of light, fan and 5 A socket outlets. The load of such circuit shall be restricted to 800 Watts. Power sub-circuit shall be designed according to the load but in no case shall there be more than two 15 A outlets on each sub-circuit.
- The load on any low voltage sub circuit shall not exceed 3000 Watts. In case of new installation, all circuits and sub-circuits shall be designed by making a provision of 20% increase in load due to any future modification.
- The distribution fuse board shall be located as near as possible to the centre of the load. These shall be fixed in suitable stanchion or wall and shall not be more than 2 m from the floor level.
- All conductors shall be of copper or aluminium. Conductor for final sub-circuit of fan and light wiring shall have a nominal cross sectional area not less than 1 Sq. mm copper and 1.5 Sq. mm aluminium. The cross sectional area for power wiring shall be not less than 2.5 Sq. mm copper, 4 Sq. mm aluminium. The minimum cross sectional area of conductors of flexible cord shall be 0.5 Sq. mm copper.

Design considerations of electrical installation system for commercial building

Load calculation and selection of size of service connection and nature of supply,

Deciding the size of the cables, busbar and bus bar chambers

Next step is finding Bus bar size.

Bus bar materials are:

- Aluminum or Aluminium alloy – working current density, 0.8 A/ Sq.mm
- Copper – working current density, 1.2 A/ Sq.mm
- For the above set up:-

$$250/0.8 = 312.5 \text{ Sq. mm}$$

For neutral bus bar, half the size of phase bus bar size is sufficient.

ie, 40 x 8 mm or 50 x 6 mm Al bus bar may be used for phases and 20 x 8 mm or 25 x 6 mm for neutral.

Or

31 x 6 mm Cu bus bar may be used for phases and 31 x 3 mm for neutral.

f For small switch boards the distance between the bus supports will be 50 cms.

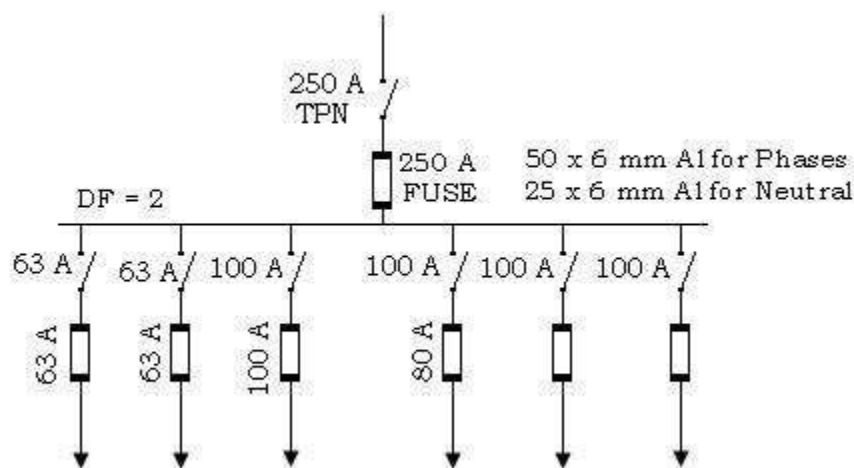

- f* If DF is not given, we can assume, DF as 2 for all switch boards.
- f* The term ampacity is some times used to denote the maximum current rating of the feeders. If DF is not clearly known, the total ampacity of outlet feeders shall not be more than two times the ampacity of the incomer feeder.
- f* The feeder cables need to be selected for the fuse used in the SFU.
 - Eg:- when we want 125A feeder, the fuse and cable corresponding to 125A. But the switch may be 200A, since above 100A, only 200A switch is available.
- f* Standard switch ratings are: 32A, 63A, 100A, 200A, 250A, 400A, 630A AND 800A. Some manufactures makes 125A and 320A also.

f

Mounting arrangements and positioning of switchboards, distribution boards main switch etc

Switch boards in general are power distribution centers with SFUs/MCCBs/ACBs/OCBs for controlling outlets and incomer. Unlike DBs, switch boards are specified by its total current carrying capacity or incomer current rating. Where as in DBs current rating of the outlet is the specified rating. Standard switch board ratings are 100 A, 200 A, 400 A, 800 A, 1200 A, 1600 A, 2000 A, 2500 A and 3200 A. If the incomer supply is controlled with an SFU, the switch board is called switch fuse controlled board and if the incomer is ACB/ OCB controlled, it is called breaker controlled board.

A switch board having three sections

- f* Outlet control gears
- f* Bus chamber
- f* Incomer control gear

The outlet switch, fuse and cable rating are decided by the load that has to be handled through that feeder. If the number of loads is more, SSB is required, which is installed almost at the load centers. In smaller set up SSB may not be necessary and MSB will be the only switch board.

DB / DFB (Distribution Fuse Board) / FDB (Fuse Distribution Board)

Usually even numbers of ways are used in DBs (2, 4, 6, 8, 10 and 12). As per IS the maximum number of ways is limited to 12.

Eg- 12 way 3 ph DB = 4 x 12 = 48 cable connection including neutral.

Usual current rating of DB s are : 16A, 32A and 63A

63A, 12 way DB s are not common. Since maximum input current=63 X 12 =700A which is not possible to handle by a DB. Hence 63A DB is 2 ways or 4 ways.

Motor loads up to 20 hp are fed from DB s of various rating.

All DBs have isolator or SFU as incomer switch. But in some case this is avoided if the switch board supplying to the DB is within 3m from the DB

In a designed system 20% spare outlets are kept for future expansion. ie, in each DB, 1 or 2 outlets shall be kept as spares

Earthing of the electrical installation

Design data on earth electrode

Standard earth electrodes are;

- (a) Rod and pipe electrodes, (b) Strip or conductor electrodes, (c) Plate electrodes, and (d) Cable sheaths.

Measurement	Type of Electrodes				
	Rod	Pipe	Strip	Round conductor	Plate
Diameter(not less than)	16 mm (Steel or GI)	38 mm (Steel or GI) 100 mm		tor	

		Iron)			
Length/ Depth of burial (not less than)	2.5 m (ideal 3 to 3.5 m)	2.5 m	0.5 m	1.5 m	1.5 m
Size	-	-	25 x 1.60 mm (copper) 25 x 4 (Steel or GI)	3.0 Sq. mm (copper) 6 Sq. mm (Steel or GI)	60 x 60 cm
Thickness	-	-	-	-	6.30 mm (copper) 3.15 mm (Steel or GI)

Selection of type wire, wiring system and layout

Selection of rating of incomer isolator/SFU and incomer feeder size :

In any system, all the connected loads will not be put on simultaneously. This reduces the maximum demand from simply computing by adding all connected loads. The maximum demand is expressed through a factor called 'Diversity Factor,

$$\text{Diversity Factor (DF)} = \frac{\text{Sum of connected load}}{\text{Simultaneous max.demand(MD)}} > 1$$

From the requirement data, the details of connected load on each DB are known to us. For spare outlets, an average of other outlets can be assumed.

If the DF is known, we can find the maximum current requirement of the DB to feed all loads

including spares. Instead of furnishing the DF, a usual practice is specifying MD. A commonly accepted and safe value of DF is 1.5. this value can be assumed for each DB

If motor loads are connected, for selection of isolator / SFU, the starting current has to be taken in to account rather than continuous current. Eg:- 5 hp - 5Nos and 10 hp - 2Nos motors are connected to a DB

Total connected load = 45hp

MD = $4.5 \times 1.5 = 30$ hp

Corresponding maximum current is $30 \times 1.4 = 42$ A. This current is the continuous maximum current

When motors are started we have to account the starting inrush current of large motor in the down stream. Starting current of DOL starting motor is 2.5 times the rated current and for assisted starting (star delta), it is 1.5 times the rated current.

So the MD calculation in the above case is as follows:

- f One 10 hp (one higher rating) kept aside
- f Now only MD of 20 hp is existing
- f Its maximum current = $20 \times 1.4 = 28$ A
- f For one 10 hp alone, maximum current = $2.5 \times (10 \times 1.4) = 35$ A
- f Therefore MD of the DB = $28 + 35 = 63$ A
- f ie, incoming feeder, isolator/SFU of the DB can be rated to 63 A

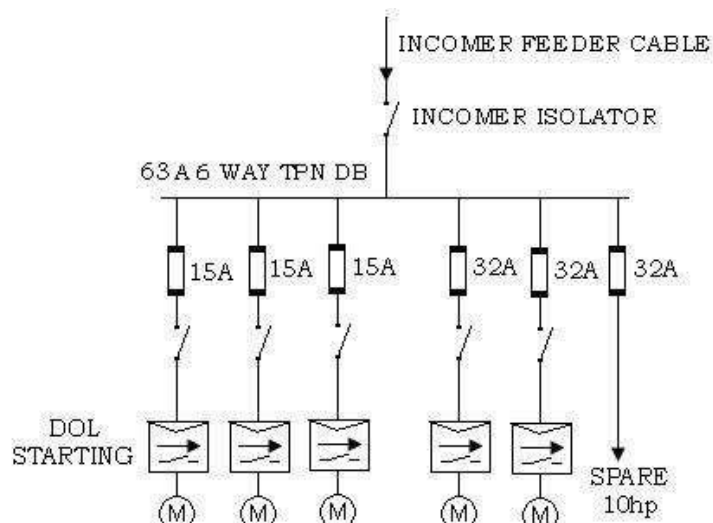

Sequence to be followed to prepare estimate

The feeder to a DB will be fed from an SSB or MSB. This feeder will be protected by the HRC fuse in the SSB or MSB. It is necessary that the feeder protective fuse should not blow off before the motor protective fuse in the DB. This is achieved by proper grading between the fuses. The fuse of SSB/MSB is denoted as major fuse and that of DB is termed as minor fuse. For achieving grading the ratio between major and minor fuses shall be 2:1 or more

Feeder cable is selected by considering the 20% excess of the MD of DB. Also major fuse rating should match with the cable selection.

If the cable length exceeds 75 to 100mtr, the voltage drop condition should be taken in to account. The voltage drop in the feeder should not be more than 3% in the maximum demand condition.

Preparation of detailed estimate and costing of commercial installation.

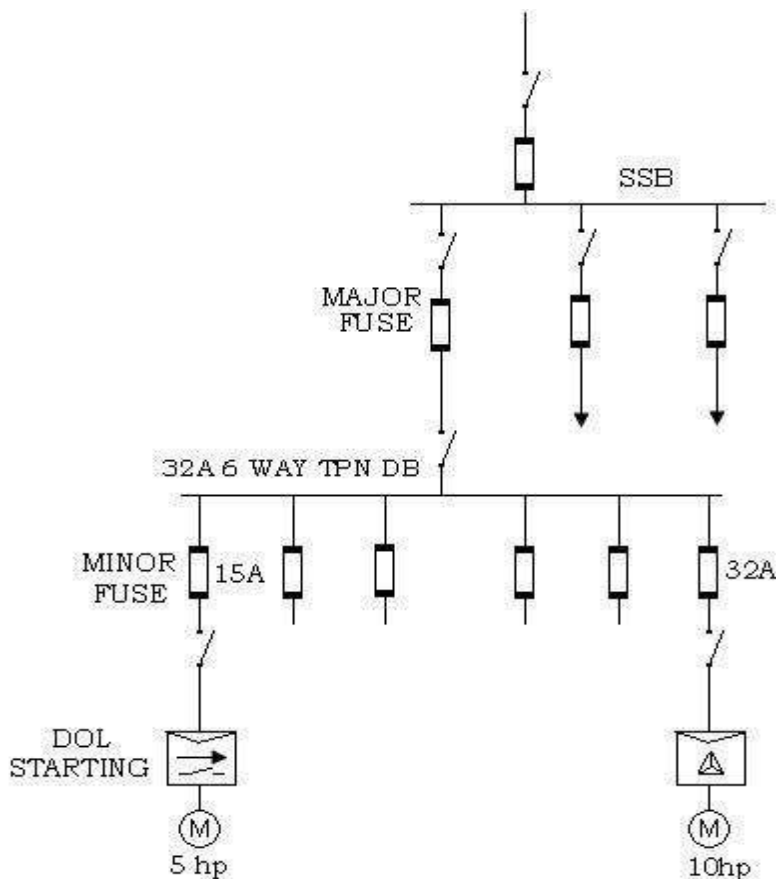

MODULE 3

Service Mains: Introduction, Types, Estimation of Underground and Overhead Service Connections.

Design and Estimation of Power Circuits: Introduction, Important Considerations Regarding Motor Installation Wiring, Input Power, Input Current to Motors, Rating of Cables, Rating of Fuse, Size of Conduit, Distribution Board Main Switch and Starter.

8 Hours

SERVICE MAINS

Introduction:

We depend on electricity to light our homes, turn on our television sets, and even cook our meals. When the power goes out because of a storm, a short circuit, or another problem in the electrical circuit, understanding what the basic components of an electrical system is a must.

Your homes' electricity starts with the electrical service connection. This is where the electric company connects their wires to your homes' feeder wires that attach to the meter on your home or power pole. This is the device that measures the amount of electricity your home uses and determines the amount of money the electric company charges you on a monthly basis.

From here your meter either feeds a disconnect switch or a main breaker or fuse panel. A typical home has a single phase service consisting of an "A" phase and a "B" phase, a neutral and a ground wire.

Disconnect Switch

A disconnect switch is mounted on the outside of your home close in proximity to the meter on the outside of your home or power pole. The advantage of having a disconnect switch is for safety. In the event of a fire or flash flood, you can shut the power off from the outside of your home versus having to enter a burning home or a flooded basement.

The other instance is having a transfer switch in which you can switch between live power and a

generator for backup power.

Main Breaker

A breaker panel consists of a main breaker that is sized according to your homes' load needs. It is used to turn the power on and off to the entire electrical panel. Typically, homes have a 100 amp or a 200 amp service.

A main breaker of 100 amps will only allow 100 amps to flow through it without tripping. In a tripped state, no current will flow throughout the panel. It is the interrupt between the service and the branch circuits of the panel.

This main breaker protects the main service wires from damages that would occur given an overload. In that case, the wires would heat up and eventually could cause a fire.

Branch Circuit Breakers

Breakers that feed lighting, outlets, central air conditioning and sub-panels are considered branch circuits. These circuits can either be 120 volts or 240 volts.

The 120 volt circuits require a single pole breaker, using only one phase of the electrical service. These circuits provide power to lighting, outlets and furnaces. The breakers are usually sized at 15 or 20 amps.

In a 240 volt circuit, a two-pole breaker uses both phases of a circuit. Examples of 240 volt appliances would be an electric range, an electric stove or central air conditioning.

These appliances don't work unless both "A" and "B" phases are working. Most of these examples would require a two-pole 30 amp breaker.

Remember to size your breaker by the name plate rating on the device you are connecting to.

Switches

Switches are the devices that turn on and off lights and fans in your home. These switches come in many different styles and colors to suit your design needs. There are single-pole, three-way, four-way and dimmer switches. Their purpose is to alter the flow of current to your lights and fans in a home.

Outlets

Electrical outlets are used to plug portable devices into. Televisions, lights, computers, freezers, vacuums and toasters are all good examples of devices that can be plugged into an outlet.

Outlets consist of a hot feed, a neutral and a ground. Some outlets are used especially for wet areas.

Wiring

Your home's wiring consists of romex, BX cable or wiring concealed in conduit. Romex is a brand name for a type of plastic insulated wire. The formal name is NM that means non-metallic sheath. This is suitable for use in dry, protected areas (inside stud walls, on the sides of joists, etc.), that are not subject to mechanical damage or excessive heat.

Bx cable is known as armored cable. Wires are covered by aluminum or steel flexible sheath that is somewhat resistant to damage.

Single strands of conductor wire are pulled through conduit that is the safest method for wiring for durability purposes.

These different types of wiring carry electrical current from the panel to the device being fed. Wiring is sized according to the load demand required. Check the rated required load requirements marked on each device to determine the needed size wire to carry the needed load.

Types of service connection and their features:

This describes various types of utility electrical services and supply voltages. The nominal system supply voltages listed below can vary by $\pm 10\%$ or more. Watt Node meter models are available in seven different versions that cover the full range of electrical services types and voltages. Meters and current transformers are designed for use on either 50 or 60 Hz systems.

Classification of Different Services:

Alternating current electric power distribution systems can be classified by the following properties:

- **Frequency:** 50 Hz or 60 Hz
- **Number of phases:** single or three phase
- **Number of wires:** 2, 3, or 4 (not counting the safety ground)
- **Neutral present:**
 - **Wye** connected systems have a neutral
 - **Delta** connected systems typically do not have a neutral
 - **Voltage levels:**
 - **Low Voltage:** 600 volts or less
 - **Medium Voltage:** 601 volts to about 34,500 volts
 - **High Voltage:** 46,000 volts and up

Wye Line-to-Neutral Voltage	Wye or Delta Line-to-Line Voltage
120	208
120	240
230	400
240	415
277	480
347	600

- Line-to-line voltages are typically 1.732 times the phase-to-neutral voltages: $\sqrt{3} = 1.732$
- In symmetrical three-phase electrical system, the phase-to-neutral voltages should be

equal if the load is balanced.

MODULE – 3

ELECTRICAL INSTALLATION FOR POWER CIRCUITS:

Introduction:

Electrical wiring in general refers to insulated conductors used to carry electricity, and associated devices. This article describes general aspects of electrical wiring as used to provide power in buildings and structures, commonly referred to as building wiring. This article is intended to describe common features of electrical wiring that may apply worldwide. For information regarding specific national electrical codes, refer to the articles mentioned in the next section. Separate articles cover long-distance electric power transmission and electric power distribution.

Important considerations regarding motor installation wiring:

Electric motors are used in a wide variety of applications that affect our daily lives. Electric motors are the tools that use the alternating current (AC) power supplied to your home or shop by the power distribution company and transform it to mechanical energy to drive compressors, fans, tools, washing machines, garage door openers, and anything else that requires mechanical motion to operate. AC power is brought into your house or shop in 3 phases, each of them 120 volts AC when referred to an electrical neutral, but 120 electrical degrees out of phase with each other. Ground is different from the electrical neutral, and is provided only for protection from electric shock. Smaller motors are generally wired as 1 phase to neutral, providing them with single phase AC power. Larger motors are generally wired as 3 phase AC motors, using all 3 phases of incoming power and not connecting to the electrical neutral line. In addition, direct current (DC) motors can be used in battery power applications that do not have AC. All of these types of motors must be wired properly to perform the desired motion, and all are wired differently. Use these tips to learn how to wire an electric motor.

1. Check the voltage rating of the motor. The rated operating voltage will be listed on the nameplate of the motor. For example, a motor intended to run from a 12-volt car battery should be rated at 12 volts.

2. Determine the rotation. The motor faceplate will define which direction, clockwise or counter clockwise, the motor shaft will turn when the 2 motor wires are connected to the power source. The motor nameplate or manufacturer's information will specify which of the 2 motor wires should be connected to the positive side of the power source and which should be connected to the negative side of the power source to achieve the desired direction of rotation.

3. Establish the direction of motor rotation. Consult the motor nameplate or manufacturer's information for this information. That information should direct that 1 motor wire be attached to 1 (any 1) of the 3 power phases available and the other motor wire be attached to electrical neutral.

Count the motors being driven by the 3 phase input power in a line to neutral configuration. Attempt to balance the power being drawn from each of the 3 available phases so that the neutral line is carrying as little current as possible. A high neutral current can unbalance the power system and cause poor motor performance.

4. Wire the motor. Use wire strippers, available at hardware or electrical supply stores, to strip about half an inch (13 mm) of insulation from the end of the motor wire. Secure the motor wire under the screw termination available on the power distribution panel. Confirm that the motor rotates in the proper direction. If the motor does not rotate in the desired direction, the input leads may be swapped to reverse the motor direction of rotation.

Connect a 3 Phase AC Motor

Confirm that the motor is a 3 phase AC motor. This information will be on the motor faceplate. It also can be noted that the motor has 3 connecting wires, rather than 2. Confirm from the motor faceplate the operating voltage that the motor will require from the power distribution system.

2. Figure out the direction that the motor will turn. The motor nameplate and motor manufacturer's information should explain the needed wiring to make the motor turn in a particular direction.

3. Attach the motor power leads. Wire the 3 motor leads to the 3 phases of input power. Do not use the neutral line. If the motor does not turn in the desired direction, swap any 2 of the 3 motor wires to reverse the direction of rotation of the motor.

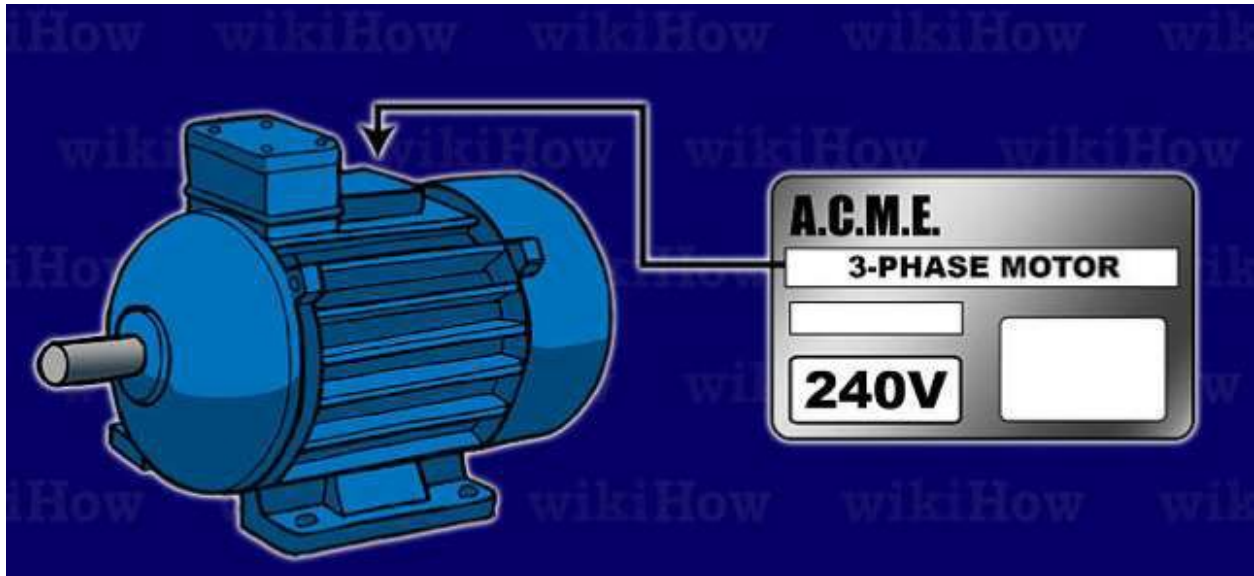

Determination of input power:

Reasons to Determine Motor Loading

Most electric motors are designed to run at 50% to 100% of rated load. Maximum efficiency is usually near 75% of rated load. Thus, a 10-horsepower (hp) motor has an acceptable load range of 5 to 10 hp; peak efficiency is at 7.5 hp. A motor's efficiency tends to decrease dramatically below about 50% load. However, the range of good efficiency varies with individual motors and tends to extend over a broader range for larger motors, as shown in Figure 1. A motor is considered under loaded when it is in the range where efficiency drops significantly with decreasing load. Figure 2 shows that power factor tends to drop off sooner, but less steeply than efficiency, as load decreases.

Figure 1 Motor Part-Load Efficiency (as a Function of % Full-Load Efficiency)

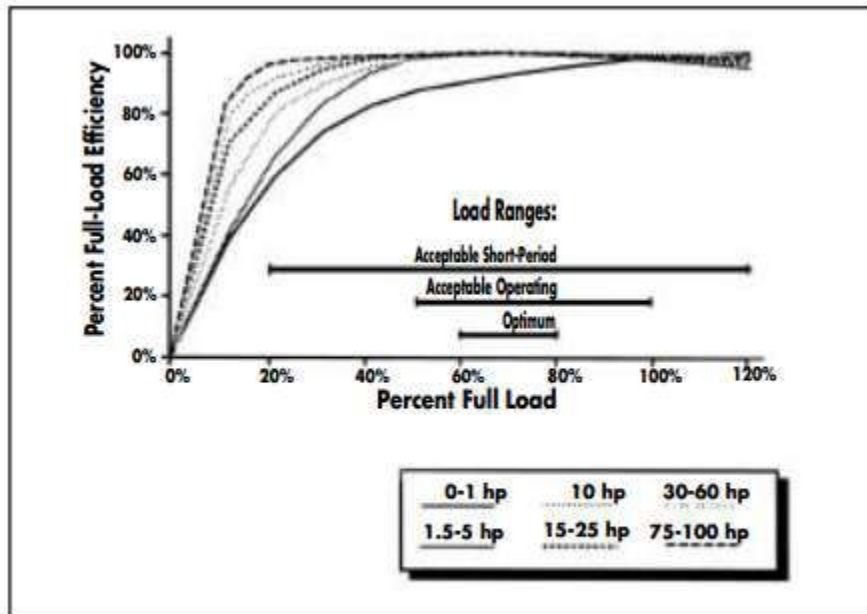

Figure 1 Motor Part-Load Efficiency (as a Function of % Full-Load Efficiency)

Determining Motor Loads

Input Power Measurements

When “direct-read” power measurements are available, use them to estimate motor part-load. With measured parameters taken from hand-held instruments, you can use Equation 1 to calculate the three-phase input power to the loaded motor. You can then quantify the motor’s part-load by comparing the measured input power under load to the power required when the motor operates at rated capacity. The relationship is shown in Equation 3.

Equation 1

$$P_i = \frac{V \times I \times PF \times \sqrt{3}}{1000}$$

Where:

- P_i = Three-phase power in kW
- V = RMS voltage, mean line-to-line of 3 phases
- I = RMS current, mean of 3 phases
- PF = Power factor as a decimal

Equation 2

$$P_{ir} = hp \times \frac{0.7457}{\eta_n}$$

Where:

- P_{ir} = Input power at full-rated load in kW
- hp = Nameplate rated horsepower
- η_n = Efficiency at full-rated load

Equation 3

$$Load = \frac{P_i}{P_{ir}} \times 100\%$$

Where:

- Load = Output power as a % of rated power
- P_i = Measured three-phase power in kW
- P_{ir} = Input power at full-rated load in kW

Determination of rating of cables: Cable

insulation materials

Rubber

For many years wiring cables were insulated with vulcanised natural rubber (VIR). Much cable of this type is still in service, although it is many years since it was last manufactured. Since the insulation is organic, it is subject to the normal ageing process, becoming hard and brittle. In this condition it will continue to give satisfactory service unless it is disturbed, when the rubber cracks and loses its insulating properties. It is advisable that wiring of this type which is still in service should be replaced by a more modern cable. Synthetic rubber compounds are used widely for insulation and sheathing of cables for flexible and for heavy duty applications. Many

variations are possible, with conductor temperature ratings from 60°C to 180°C, as well as resistance to oil, ozone and ultra-violet radiation depending on the formulation.

Paper

Dry paper is an excellent insulator but loses its insulating properties if it becomes wet. Dry paper is hygroscopic, that is, it absorbs moisture from the air. It must be sealed to ensure that there is no contact with the air. Because of this, paper insulated cables are sheathed with impervious materials, lead being the most common. PILC (paper insulated lead covered) is traditionally used for heavy power work. The paper insulation is impregnated with oil or non-draining compound to improve its long-term performance. Cables of this kind need special jointing methods to ensure that the insulation remains sealed. This difficulty, as well as the weight of the cable, has led to the widespread use of p.v.c. and XLPE (thermosetting) insulated cables in place of paper insulated types.

P.V.C.

Polyvinyl chloride (p.v.c.) is now the most usual low voltage cable insulation. It is clean to handle and is reasonably resistant to oils and other chemicals. When p.v.c. burns, it emits dense smoke and corrosive hydrogen chloride gas. The physical characteristics of the material change with temperature: when cold it becomes hard and difficult to strip, and so BS 7671 specifies that it should not be worked at temperatures below 5°C. However a special p.v.c. is available which remains flexible at temperatures down to -20°C.

At high temperatures the material becomes soft so that conductors which are pressing on the insulation (eg at bends) will 'migrate' through it, sometimes moving to the edge of the insulation. Because of this property the temperature of general purpose P.V.C. must not be allowed to exceed 70°C, although versions which will operate safely at temperatures up to 85°C are also available. If p.v.c. is exposed to sunlight it may be degraded by ultra-violet radiation. If it is in contact with absorbent materials, the plasticiser may be 'leached out' making the p.v.c. hard and brittle.

LSF (Low smoke and fume)

Materials which have reduced smoke and corrosive gas emissions in fire compared with p.v.c.

have been available for some years. They are normally used as sheathing compounds over XLPE or LSF insulation, and can give considerable safety advantages in situations where numbers of people may have to be evacuated in the event of fire.

Thermosetting (XLPE)

Gross-linked polyethylene (XLPE) is a thermosetting compound which has better electrical properties than p.v.c. and is therefore used for medium- and high-voltage applications. It has more resistance to deformation at higher temperatures than p.v.c., which it is gradually replacing. It is also replacing PILC in some applications. Thermosetting insulation may be used safely with conductor temperatures up to 90°C thus increasing the useful current rating, especially when ambient temperature is high. A LSF (low smoke and fume) type of thermosetting cable is available.

Mineral

Provided that it is kept dry, a mineral insulation such as magnesium oxide is an excellent insulator. Since it is hygroscopic (it absorbs moisture from the air) this insulation is kept sealed within a copper sheath. The resulting cable is totally fireproof and will operate at temperatures of up to 250°C. It is also entirely inorganic and thus non-ageing. These cables have small diameters compared with alternatives, great mechanical strength, are waterproof, resistant to radiation and electromagnetic pulses, are pliable and corrosion resistant. In cases where the copper sheath may corrode, the cable is used with an overall LSF covering, which reduces the temperature at which the cable may be allowed to operate. Since it is necessary to prevent the ingress of moisture, special seals are used to terminate cables. Special mineral-insulated cables with twisted cores to reduce the effect of electromagnetic interference are available.

Non-flexible low voltage cables

Types of cable currently satisfying the Regulations are shown in {Fig 4.1}.

a) Non-armoured pvc-insulated cables - Fig 4.1a

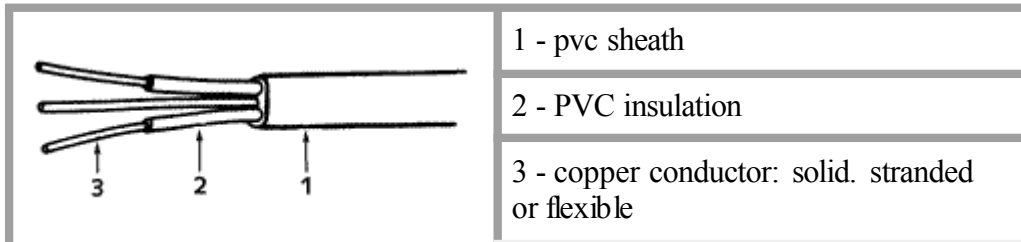

b) Armoured PVC-insulated cables - Fig 4.1b

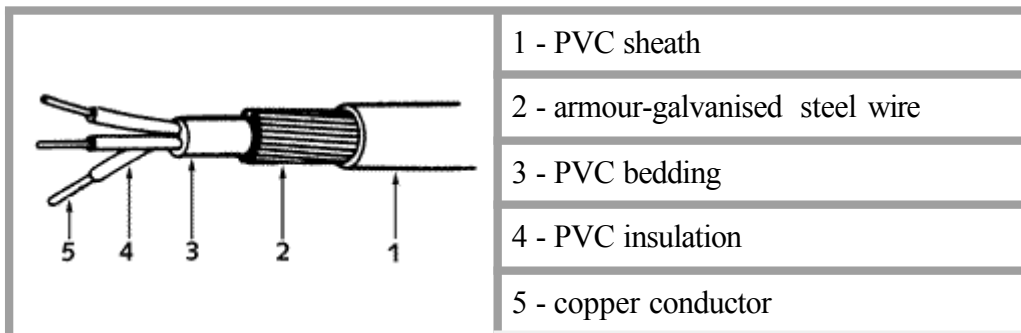

c) Split-concentric PVC insulated cables - Fig 4.1c

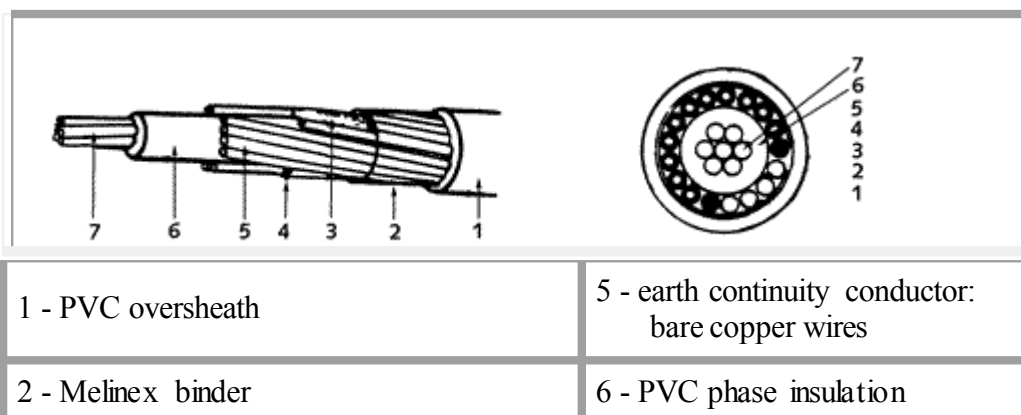

3 - PVC strings	7 - copper conductors
4 - neutral conductor: black PVC-covered wires	

d) Rubber-insulated (elastomeric) cables - Fig 4.1d

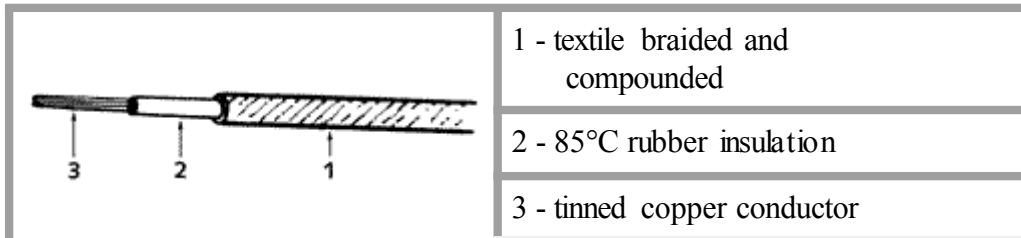

Flexible low voltage cables and cords

By definition flexible cables have conductors of cross-sectional area 4 mm² or greater, whilst flexible cords are sized at 4 mm² or smaller. Quite clearly, the electrician is nearly always concerned with flexible cords rather than flexible cables.

{Figure 4.2} shows some of the many types of flexible cords which are available.

a) Braided circular - Fig 4.2a

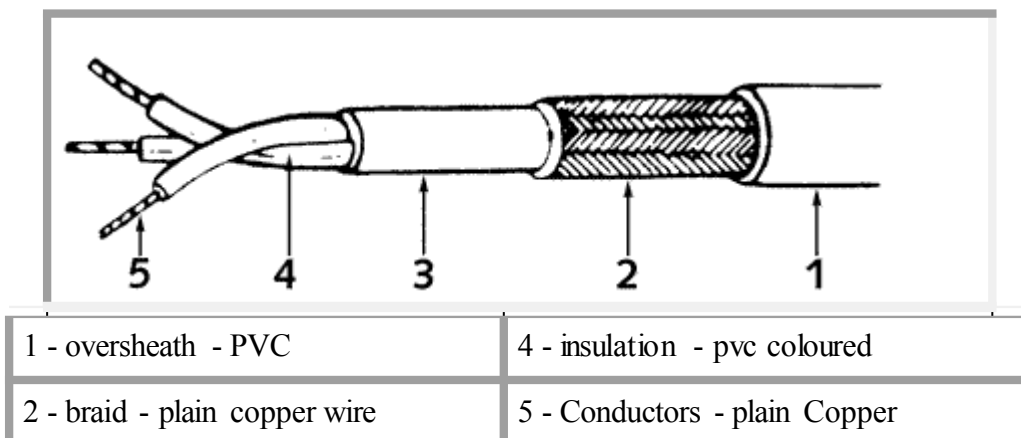

3 - inner sheath - pvc	
------------------------	--

b) Unkinkable - Fig 4.2b

	1 - rubber layer collectively textile braided semi-embedded
	2 - insulation (Cores) 60°C rubber
	3 - conductors - tinned copper

c) Circular sheathed - Fig 4.2c

	1 - sheath - rubber or pvc
	2 - insulation 60°C rubber or pvc
	3 - conductors - tinned copper

d) Flat twin sheathed - Fig 4.2d

	1 - sheath - PVC
	2 - insulation - pvc
	3 - conductors - plain copper

e) Braided circular insulated with glass fibre - Fig 4.2e

	1 - glass braided overall
--	---------------------------

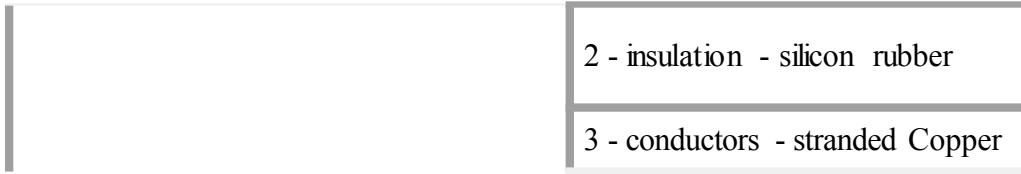

f) Single core p.v.c. - insulated non-sheathed - Fig 4.2f

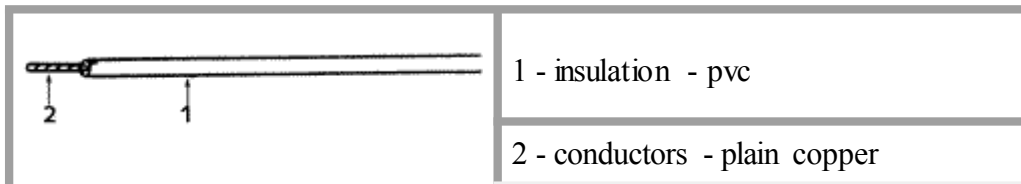

Flexible cables should not normally be used for fixed wiring, but if they are, they must be visible throughout their length. The maximum mass which can be supported by each flexible cord is listed in (Table 4H3A), part of which is shown here as (Table 4.2).

Table 4.2 - Maximum mass supported by twin flexible cord	
Cross-sectional area (mm ²)	Maximum mass to be supported (kg)
0.5	2
0.75	3
1.0	5
1.25	5
1.5	5

The temperature at the cord entry to luminaires is often very high, especially where filament lamps are used. It is important that the cable or flexible cord used for final entry is of a suitable heat resisting type, such as 150°C rubber- insulated and braided. (Fig 4.3) shows a short length of such cord used to make the final connection to a luminaire.

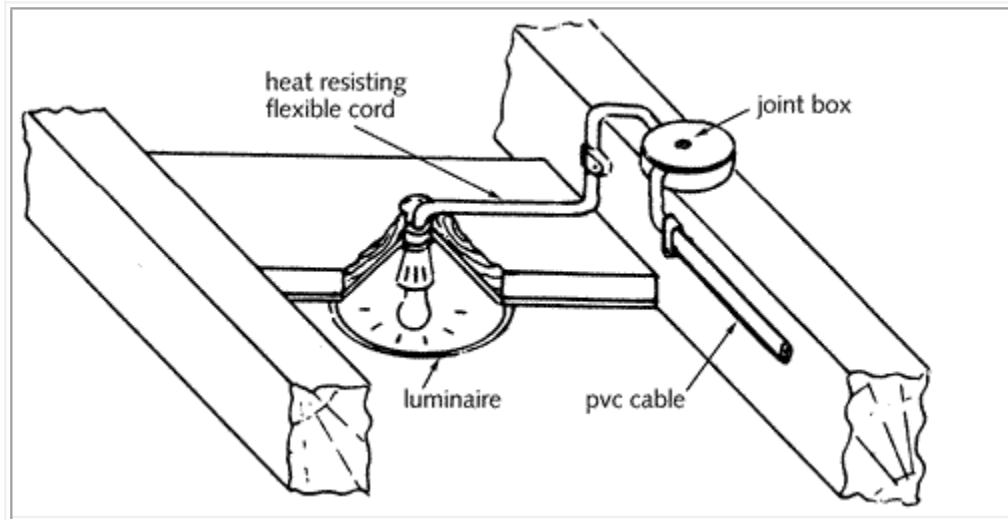

Fig 4.3 - 150°C rubber-insulated and braided flexible cord used for the final connection to a luminaire

Determination of rating of fuse:

The question of determining fuse size has been a common one lately so we decided to make a quick write up on choosing the correct fuse size. One common misconception about choosing the correct fuse size is that it's dependent the load of the circuit. Actually, the load of the circuit should have nothing to do with choosing a fuse size. The fuse size should be based on the SMALLEST wire (largest gage number) in the circuit. Here is how to correctly choose the right fuse size for your circuit.

- 1) Determine the wire gage you already have by locating it on the package or measuring it, you can also look at the topic this was posted in on Oznum forums for a step by step guide to finding the amperages for common products at the Oznum store.
- 2) Use the following table to determine the maximum current for whatever wire gage is being used.

The application guidelines and product data in this guide are intended to provide technical information that will help with application design. Since these are only a few of the contributing parameters, application testing is strongly recommended and should be used to verify performance in the circuit/application.

Many of the factors involved with fuse selection are listed below. For additional assistance with choosing fuses appropriate to your requirements, contact your Littelfuse products representative.

Selection Factors

1. Normal operating current
2. Application voltage (AC or DC)
3. Ambient temperature
4. Overload current and length of time in which the fuse must open
5. Maximum available fault current
6. Pulses, Surge Currents, Inrush Currents, Start-up Currents, and Circuit Transients
7. Physical size limitations, such as length, diameter, or height
8. Agency Approvals required, such as UL, CSA, VDE, METI, MITI or Military
9. Fuse features (mounting type/form factor, ease of removal, axial leads, visual indication, etc.)
10. Fuse holder features, if applicable and associated rerating (clips, mounting block, panel mount, PC board mount, R.F.I. shielded, etc.)
11. Application testing and verification prior to production

Distribution Board main switch and starter:

Power Distribution Board is a panel that has got fuses, circuit breakers and ground leakage protection components required to distribute electrical power to many individual circuits or end user points. It divides an electrical power feed into subsidiary circuits and provides protective fuse for each circuit placed within a common panel. It is through this main distribution board, the electricity is supplied to the Sub Main Distribution Board (SMDB) and electricity goes to the panels for further distribution.

Power Distribution Boards are common for most of the industrial or commercial electrical installations or for residential buildings. To have safe installation of electricity, it is important that the work gets done from the best technical house. Designing and building the electrical projects and implementing them flawlessly are not a small task that can get handled by any electrical company. Right technical expertise is needed to accomplish the job. To build the projects as per the requirements of the customers, innovative designs are to be made so that clients have safe and uninterrupted power supply. The clients include end users, commercial houses, and industries as well as other electrical contractors in North India including Punjab, Haryana, and Chandigarh etc. It is important to keep high standards in the work they deliver as the part of electrical contracting services. Offering premium quality of work is important so that clients get value for their money.

General features of Main Distribution Board

- Busbars and incoming terminals are fully shrouded
- Box type terminals are provided on outgoing MCCBs for termination of cables, reducing connection costs
- Metering section and cable plinth can be provided

INCOMER	Load break switch 125 to 800A, 3P with external rotary handle MCCB 100 to 800A, 3-pole, 30kA or 50kA.
OUTGOINGS	MCCBs 15 to 400A, 3 pole, 30kA or 50kA
BUS BARS	H.C.H.D. copper, electrolytic ally tinned and colour coded
ENCLOSURE	Electro galvanized sheet steel, polyester powder coated to RAL 7032 textured, or as per requirement suitable for floor and wall mounting
CABLING	Removable undrilled gland pates on top and bottom, non-ferrous type for single core cables, punched to clients requirements Termination for up to 4 cables per phase can be provided

As per the specifications given by the clients, an exclusive range of **power distribution board** is designed by the best-in-class technicians at Advance Switchgear Co. They are the **manufacturers** of one of the safest and cost-effective **SMDB** that complies with the quality standard. There is reliable after sales service provided by the company that saves installation cost, cost of equipment storage and field testing.

Starter and its Importance:

A 3 point starter in simple words is a device that helps in the starting and running of a shunt wound dc motor or compound wound dc motor. Now the question is why these types of dc motors require the assistance of the starter in the first case. The only explanation to that is given by the presence of back emf E_b , which plays a critical role in governing the operation of the motor. The back emf, develops as the motor armature starts to rotate in presence of the magnetic field, by generating action and counters the supply voltage. This also essentially means, that the back emf at the starting is zero, and develops gradually as the motor gathers speed.

MODULE 4

Estimation of Overhead Transmission and Distribution Lines: (Review of Line Supports, Conductor Materials, Size of Conductor for Overhead Transmission Line, Types of Insulators)

[No

Question Shall be Set From the Review Portion].

Cross Arms, Pole Brackets and Clamps, Guys and Stays, Conductors Configuration Spacing and Clearances, Span Lengths, Lightning Arrestors, Phase Plates, Danger Plates, Anti Climbing Devices, Bird Guards, Beads of Jumpers, Muffs, Points to be Considered at the Time of Erection of Overhead Lines, Erection of Supports, Setting of Stays, Fixing of Cross Arms, Fixing of Insulators, Conductor Erection.

Estimation of Overhead Transmission and Distribution Lines (continued): Repairing and Jointing of Conductors, Dead End Clamps, Positioning of Conductors and Attachment to Insulators, Jumpers, Tee-Offs, Earthing of Transmission Lines, Guarding of Overhead Lines, Clearances of Conductor From Ground, Spacing Between Conductors, Important Specifications.

8 Hours

TEXT BOOK:

1. Electrical Installation Estimating & Costing, J.B.Gupta, VIII Edition S.K. Katria & Sons New Delhi

REFERENCE BOOKS:

**1. Electrical Design Estimating and Costing, K.B.Raina S.K.Bhattacharya,
New Age International**

2. Electrical Wiring Estimating and Costing, Uppal, Khanna Publishers Delhi

3. I.E.Rules and Act Manuals

MODULE - 4

DESIGN AND ESTIMATION OF OVERHEAD TRANSMISSION & DISTRIBUTION LINES:

Introduction, Typical AC electrical power system:

An electric power system is a network of electrical components used to supply, transmit and use electric power. An example of an electric power system is the network that supplies a region's homes and industry with power - for sizable regions, this power system is known as [*the grid*](#) and can be broadly divided into the [generators](#) that supply the power, the [transmission system](#) that carries the power from the generating centres to the load centres and the [distribution system](#) that feeds the power to nearby homes and industries. Smaller power systems are also found in industry, hospitals, commercial buildings and homes. The majority of these systems rely upon [three-phase AC power](#) - the standard for large-scale power transmission and distribution across the modern world. Specialised power systems that do not always rely upon three-phase AC power are found in aircraft, electric rail systems, ocean liners and automobiles.

Modern ac power systems usually consist of the (i) generating stations (ii) step up transformer stations (iii) transmission lines (iv) switching stations (v) step down transformer stations (vi) primary (high voltage) distribution lines or net-works (vii) service transformer banks (viii) secondary (low voltage) distribution lines. Essentially elements (ii), (iii), (iv) and (v) fall in the transmission system and distribution may or may not include all elements enumerated above; for example, some systems may have no primary transmission, some may not have secondary transmission and the others may not have transmission at all, being very small and so on.

Generation voltages are 3.3, 6.6, 11 or 33 kv, most usual value adopted in practice is 11 kv. The primary transmission voltages are 110, 132, 220 or 400 kv depending upon the distance, the amount of power to be transmitted and the system stability. Secondary transmission voltage is normally of the order of 33 or 66 kv. The voltages for primary distribution are 1, 6.6 or 3.3 kv depending upon the requirements of the bulk consumers and for secondary distribution usable voltage is 400 volts.

The distribution system may further be divided into feeders (conductors connecting the stations, in some cases generating stations, to the areas to be fed by those stations), distributors

(conductors from which numerous tapings for the supply to the consumer taken and service mains (the conductors connecting the consumers to the distributors).

Main components of overhead lines

The main components of an overhead line are the supports (poles or tower), cross-arms and clamps, insulators, conductors, Guys and stays, lightning arrestors, fuses and isolating switches, continuous earth wire, vee guards, guard wires, phase plates, bird guards, barbed wire, danger plates, beads for jumpers, vibration dampers etc..

Line supports, Factors governing height of pole

Line Supports. The supports used for transmission and distribution of electrical power must have the characteristics-high mechanical strength, light in weight, low initial as well as maintenance cost, longer life, good looking and easily accessible for painting and erection of line conductors.

The line supports are of various types including wood, steel, reinforced concrete poles and lattice steel towers.

- i. Wooden Poles. These are cheapest, easily available, providing insulating properties and therefore, are extensively used for distribution purposes, specially in rural areas, keeping the cost low. Their use is usually limited to low pressures (up to 22 kv) and for short spans (up to 60m). the wooden poles, well impregnated with creosote oil or any preservative compound, have life form 25 to 30 years. The disadvantage of such supports is that these need periodical inspection because they tend to rot and their life is short.
- ii. Steel Poles. The steel poles are of three types (i) rail poles (ii) tubular poles and (ii) rolled steel joists. These poles possess greater mechanical strength and so permit use of longer spans (50-80 m) but cost is higher. The average life of steel poles is more than 40 years.
- iii. RCC Poles. These give good outlook, need no maintenance, have got insulating properties and resistance against chemical action, very strong and can be used for longer spans (80-200m) and have very long life. Since these poles are very heavy, therefore, transportation cost is heavy and require care in handling and erection.

iv. Lattice Steel Towers. These are mechanically stronger and have got longer life. Due to robust construction long spans (300 m and above) can be used and are much useful for crossing fields, valleys, railway lines, rivers etc. Even though these are two to four times costlier than wooden poles, yet for tall supports and longer span these prove economical. These towers need periodical painting or galvanizing for protection against corrosion. Narrow-base lattice steel towers are used for transmission at 33 kv and broad-base lattice steel towers are used for transmission at 66 kv and above.

Conductor materials

Properties of Overhead Bare Conductors: Current Carrying Capacity

- Strength
- Weight
- Diameter
- Corrosion Resistance
- Creep Rate
- Thermal Coefficient of Expansion
- Fatigue Strength
- Operating Temperature
- Short Circuit Current/Temperature
- Thermal Stability
- Cost

Categories of Overhead Conductors: Homogeneous Conductors:

- Copper
- AAC(All Aluminum Conductor)
- AAAC (All Aluminum Alloy Conductor)
- The core consists of a single strand identical to the outer strands. Since all the strands are the same diameter, one can show that the innermost layer always consists of 6 strands,

the second layer of 12 strands, etc., making conductors having 1, 7, 19, 37, 61, 91, or 128 strands.

Non Homogeneous Conductors:

- ACAR (Aluminum Conductor Alloy Reinforced)
- ACSR (Aluminum Conductor Steel Reinforced)
- ACSS (Aluminum Conductor Steel Supported)
- AACSR (Aluminum Alloy Conductor Steel Reinforced.
- the strands in the core may or may not be of the same diameter. In a 30/7
- ACSR conductor the aluminum and steel strands are of the same diameter. In a 30/19
- ACSR they are not. Within the core or within the outer layers, however, the number of strands always increases by 6 in each succeeding layer. Thus, in 26/7 ACSR, the number of layers in the inner layer of aluminum is 10 and in the outer layer 16

Categories of Overhead Conductors

- VR (Vibration Resistance)
- Non-Specular
- ACSR / SD
- (Self Damping)

Choices of overhead depend upon: Power Delivery Requirements

- Current Carrying Capacity
- Electrical Losses Line Design Requirements
- Distances to be Spanned
- Sag and Clearance Requirements Environmental Considerations

- Ice and Wind Loading
- Ambient Temperatures

Determination of size of conductor for overhead transmission line

The breakdown strength of the cable depends upon the maximum stress it can bear. If maximum stress is less than breakdown strength, the working is safe. The break down strength for solid cables is of the order of 40 to 50. Kv/cm where as for oil filled cables it is nearly 90 kv/cm

For fixed values of the Voltage V and overall diameter D , the g_{max} will be minimum when d loge D/d is maximum and d loge D/d will be maximum if $d = D/2.71828$ and $g_{max} = 2V/d$ V/m

For the low and medium voltages cables, the diameter of the conductor determined from the above consideration i.e., $d = 2V/g_{max}$ is somewhat less than that determined from the consideration of the safe current density, therefore, the main criterion for determining conductor diameter for such cables is the current carrying capacity. On the other hand for high voltage cables the value of core diameter d determined from the above expression would, in general, give a conductor of cross-section much larger than required from the consideration of current carrying capacity. So, in order to have the desired overall diameter of the conductor without increasing the x-sectional area, the following methods may be adopted.

Decide Number of Conductor and Layer of Conductor:

- If N : number of conductors [strands], d : Diameter of strands, X : number of layers.
 - Usually the relation between N & X take as followed.

$$N = 3X^2 - 3X + 1$$

- If N is given we can used the above relation get X , then we can get the total Diameter of cable as

$$d_T = (2X - 1)d.$$

- If Total Number of Conductor (N)=19 Than $19 = 3 \times 2 - 3x + 1$. So Number of Layer (x)=3
 - Than Diameter of Cable $d_T = (2x - 1)d = 5d$

Cross arms, Pole brackets and clamps, Guys and Stays

Conductors configuration spacing and clearances, Span lengths

- 1) No conductor of an overhead line, including service lines, erected across a street shall at any part thereof be at a height less than-
 - (a) for low and medium voltage lines 5.8 metres
 - (b) for high voltage lines 6.1 metres

- (2) No conductor of an overhead line, including service, lines, erected along any street shall at any part thereof be at a height less than-
 - (a) for low and medium voltage lines 5.5 metres
 - (b) for high voltage lines 5.8 metres

- (3) No conductor of an overhead line including service lines, erected else- where than along or across any street shall be at a height less than-
 - (a) for low, medium and high voltage lines up to and including 11,000 volts, if bare ;4.6 metres
 - (b) for low, medium and high voltage lines up to and including 11,000 volts, if insulated 4.0
 - (c) for high voltage lines above 11,000 volts 5.2 metres

- (4) For extra-high voltage lines the clearance above ground shall not be less than 5.2 metres plus 0.3 metre for every 33,000 volts or part thereof by which the voltage of the line exceeds 33,000 volts: PROVIDED that the minimum clearance along or across any street shall not be less than 6.1 metres.

Voltage	Min. Ground Clearance	Fault Clear Time
400 KV	8.8 Meter	100 mille second
220 KV	8.0 Meter	120 mille second
132 KV	6.1 Meter	160 mille second
66 KV	5.1 Meter	300 mille second

33 KV	3.7 Meter	
11 KV	2.7 Meter	

Overhead line insulators, Insulator materials, Types of insulators

- There are mainly three types of insulator used as overhead insulator likewise

1. Pin Insulator
2. Suspension Insulator
3. Strain Insulator

In addition to that there are other two types of electrical insulator available mainly for low [voltage](#) application, i.e, Stay Insulator and Shackle Insulator.

- Pin Insulator is earliest developed overhead insulator, but still popularly used in power network up to 33KV system. Pin type insulator can be one part, two parts or three parts type, depending upon application voltage. In 11KV system we generally use one part type insulator where whole pin insulator is one piece of properly shaped porcelain or glass. As the leakage path of insulator is through its surface, it is desirable to increase the vertical length of the insulator surface area for lengthening leakage path. In order to obtain lengthy leakage path, one, two or more rain sheds or petticoats are provided on the insulator body. In addition to that rain shed or petticoats on an insulator serve another purpose. These rain sheds or petticoats are so designed, that during raining the outer surface of the rain shed becomes wet but the inner surface remains dry and non-conductive. So there will be discontinuations of conducting path through the wet pin insulator surface.

In higher [voltage](#) like 33KV and 66KV manufacturing of one part porcelain pin insulator becomes difficult. Because in higher voltage, the thickness of the insulator become more and a quite thick single piece porcelain insulator can not manufactured practically. In this case we use multiple part pin insulator, where a number of properly designed porcelain shells are fixed together by Portland cement to form one complete insulator Module. For 33KV two parts and for

- 66KV three parts pin insulator are generally used.



suspension insulator

- In higher voltage, beyond 33KV, it becomes uneconomical to use pin insulator because size, weight of the insulator become more. Handling and replacing bigger size single Module insulator are quite difficult task. For overcoming these difficulties, suspension insulator was developed.

In suspension insulator numbers of insulators are connected in series to form a string and the line conductor is carried by the bottom most insulator. Each insulator of a flexible suspension string. suspension string is called disc insulator because of their disc.

- Advantages of Suspension Insulator
 1. Each suspension disc is designed for normal [voltage](#) rating 11KV(Higher [voltage](#) rating 15KV), so by using different numbers of discs, a suspension string can be made suitable for any [voltage](#) level.
 2. If any one of the disc insulators in a suspension string is damaged, it can be replaced much easily.
 3. Mechanical stresses on the suspension insulator is less since the line hanged on a like shape.
 4. As the [current](#) carrying conductors are suspended from supporting structure by suspension string, the height of the conductor position is always less than the total height of the supporting structure. Therefore, the conductors may be safe from lightening.



- Stay Insulator

For low [voltage](#) lines, the stays are to be insulated from ground at a height. The insulator used in the stay wire is called as the stay insulator and is usually of porcelain and is so designed that in case of breakage of the insulator the guy-wire will not fall to the ground.

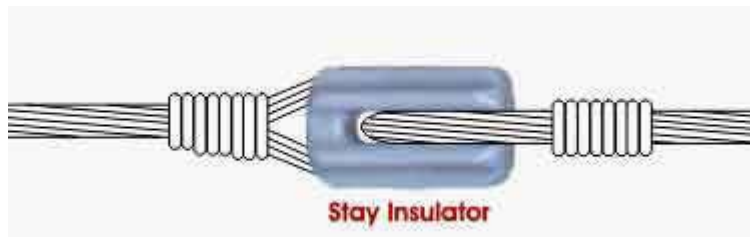

- Shackle Insulator or Spool Insulator

The shackle insulator or spool insulator is usually used in low [voltage](#) distribution network. It can be used both in horizontal and vertical position. The use of such insulator has decreased recently after increasing the using of underground cable for distribution purpose. The tapered hole of the spool insulator distributes the load more evenly and minimizes the possibility of breakage when heavily loaded. The conductor in the groove of shackle insulator is fixed with the help of soft binding wire.

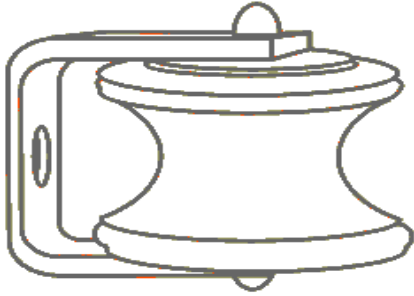

Shackle or Spool Insulator

Lightning Arrestors

LA is installed outside and the effect of lightning is grounded, whereas surge arrestor is installed inside panels comprising of resistors which consume the energy and nullify the effect of surge.

- The voltage rating of LA is selected as: $\text{Line voltage} \times \frac{\sqrt{2}}{\sqrt{3}}$ so for 11kV line it is 9kV
- In that case also the values would not differ much if we take the TOV factor as 1.4.

However, we can take the value of 1.56 as TOV to be more precise.

Phase plates, Danger plates, Anti climbing devices, Bird guards, Beads of jumpers, Muffs

Danger Plate(11KV To 220KV)

- Danger and number plates are located on Face (Feeding End (S/S)) of pole.

Anti Climbing Device(11KV To 220KV)

- Leg 1 (Right End Leg (Feeding End (S/S))) represents the leg with step bolts and anti-climb device gate if any. If two legs with step bolts are required, the next is No. 3 leg (Diagnostically opposite of Leg1)

Points to be considered at the time of erection of overhead lines

Towers may be self-supporting and capable of resisting all forces due to conductor loads, unbalanced conductors, wind and ice in any direction. Such towers often have approximately square bases and usually four points of contact with the ground.

A semi-flexible tower is designed so that it can use overhead grounding wires to transfer mechanical load to adjacent structures, if a phase conductor breaks and the structure is subject to unbalanced loads. This type is useful at extra-high voltages, where phase conductors are bundled (two or more wires per phase). It is unlikely for all of them to break at once, barring a catastrophic crash or storm.

A guyed tower has a very small footprint and relies on guy wires in tension to support the structure and any unbalanced tension load from the conductors. A guyed tower can be made in a V shape, which saves weight and cost

Erection of supports, Setting of stays

- Overhead lines supports at angles and terminal positions should be well stayed with stay wire, rod, etc. The angle between the pole and the wire should be about 45° and in no case should be less than 30°. If the site conditions are such that an angle or more than 30° between the pole and the stay wire cannot be obtained, special stays such as, foot stay, flying stay or struts may be used
- Hard drawn galvanized steel wires should be used as stay wires. The tensile strength of these wires shall not be less than 70 kgf/mm². Only standard wires should be used for staying purpose.

Fixing of cross arms, Fixing of insulators

Generally three conductors are required per AC 3-phase circuit, although single-phase and DC circuits are also carried on towers. Conductors may be arranged in one plane, or by use of several cross-arms may be arranged in a roughly symmetrical, triangulated pattern to balance the impedances of all three phases. If more than one circuit is required to be carried and the width of the line right-of-way does not permit multiple towers to be used, two or three circuits can be carried on the same tower using several levels of cross-arms. Often multiple circuits are the same voltage, but mixed voltages can be found on some structures.

Conductor erection, Repairing and jointing of conductor

Overhead Line

- Pole Foundation hole should be drilled in the ground with the use of earth-augers. However, if earth-augers are not available a dog pit of the size 1.2 x 0.6 m should be made in the direction of the line.
- The depth of the pit shall be in accordance-with the length of the pole to be planted in the ground as given in respective Indian Standards.

Tubular Pole

- Steel Tubular Poles, Rolled Steel Joists and Rails – A suitable pad of cement concrete, stone or steel shall be provided at the bottom of the pit, before the metallic pole is erected.
- Where metal works are likely to get corroded (points where the pole emerges out of the ground), a cement concrete muff, 20 cm above and 20 cm below the ground with sloping top shall be provided.

RCC Pole

- RCC poles generally have larger cross-section than the PCC poles and, therefore, the base plates or muffing are usually not provided for these types of poles.

- However, for PCC poles, a base plate (40 x 40 x 7 cm concrete block) shall be provided. Cement concrete muff with sloping top may also be provided, 20 cm above and 20 cm below-the ground level, when the ground or local conditions call for the same.

H.V Line (120m To 160m Span)

- The insulators should be attached to the poles directly with the help of 'D' type or other suitable clamps in case of vertical configuration of conductors or be attached to the cross arms with the help of pins in case of horizontal configuration
- Pin insulator; and recommended for use on straight runs and up to maximum of 10' deviation.
- The disc insulators are intended for use a pole positions having more than 30' angle or for dead ending of 11 kV lines.
- For lines having, a bend of 10" to 30', either double cross arms or disc insulators should be used for HT lines up to 11 kV. For low and medium voltage line, shackle insulators should be used
- For Vertical configuration for Conductor erection:
- Distance between Pole's Top to Disc insulation=200mm.
- Between Disc insulator to Disc Insulator=1000mm.
- Between Disc insulator to Guy Wire=500mm.

Dead end clamps, Positioning of conductors and attachment to insulators

Jumpers, Tee-offs

Earthing of transmission lines

Pole Earthing

- All metal poles including reinforced cement concrete and pre-stressed cement concrete poles shall be permanently and efficiently earthed.
- For this purpose a continuous earth wire shall be provided and securely fastened to each pole and connected with earth ordinarily at 3 points in every kilometer, the spacing

between the points being as nearly equidistant as possible. Alternatively each pole, and metallic fitting attached thereto shall be efficiently earthed.

Stay wire Earthing

- All stay wires of low and medium voltage lines other than those which are connected with earth by means of a continuous earth wire shall have an insulator inserted at a height of not less than 3 m from the ground.

Earthing Wire Size

- The cross-sectional area of the earth conductor Sims not be less than 16 mm² if of copper,

and 25 mm² if of galvanization or steel.

Guarding of overhead lines

- (1) Where guarding is required under these rules the provisions of sub-rules (2) to (4) shall apply.
- (2) Every guard-wire shall be connected with earth at each point at which its electrical continuity is broken.
- (3) Every guard-wire shall be an actual breaking strength of not less than 635
- (4) Every guard-wire or cross-connected system of guard-wires, shall have sufficient current-carrying capacity to ensure the rendering dead, without risk of fusing of the guard-wire or wires till the contact of any live-wire has been removed.
- (5) Lines crossing trolley-wires-In the case of crossing over a trolley-wire the guarding shall fulfill the following conditions, namely:-
 - (a) where there is only one trolley-wire, two guard-wires shall be erected as in diagram A;
 - (b) where there are two trolley-wires and the distance between them does not exceed 40 cms., two guard-wires shall be erected as in diagram B;
 - (c) where there are two trolley-wires and the distance between them exceeds 40cms. but does not exceed 1.2 metres, three guard-wires shall be erected
 - (d) where there are two trolley-wires and the distance between them exceeds 1.2 metres, each trolley-wire shall be separately guarded as in diagram
 - (e) the rise of the trolley boom shall be so limited that if the trolley leaves the trolley-wire, it shall not foul the guard, wires ; and
 - (f) where a telegraph- line is liable to fall or be blown down upon an arm, stay -wire or span- wire, and so slide down upon a trolley-wire-, guard hooks shall be provided to prevent such sliding.

Clearances of conductor from ground

- (1) No conductor of an overhead line, including service lines, erected across a street shall at any part thereof be at a height less than-
 - (a) for low and medium voltage lines 5.8 metres
 - (b) for high voltage lines 6.1 metres

MODULE – 8

DESIGN AND ESTIMATION OF SUBSTATIONS:

- ❖ Introduction
- ❖ Substation Classification
- ❖ Selection and location of site for substation
- ❖ Substation Earthing
- ❖ Key diagram of typical substations

Introduction

A substation is a part of an electrical generation, transmission, and distribution system. Substations transform voltage from high to low, or the reverse, or perform any of several other important functions. Between the generating station and consumer, electric power may flow through several substations at different voltage levels.

Substations may be owned and operated by an electrical utility, or may be owned by a large industrial or commercial customer. Generally substations are unattended, relying on SCADA for remote supervision and control.

A substation may include transformers to change voltage levels between high transmission voltages and lower distribution voltages, or at the interconnection of two different transmission voltages. The word substation comes from the days before the distribution system became a grid. As central generation stations became larger, smaller generating plants were converted to distribution stations, receiving their energy supply from a larger plant instead of using their own generators. The first substations were connected to only one power station, where the generators were housed, and were subsidiaries of that power station.

Substations

Electric power is produced at the power generating stations, which are generally located far away from the load centers. High voltage transmission lines are used to transmit the electric power from the generating stations to the load centers. Between the power generating station and consumers a number of transformations and switching stations are required. These are generally known as substations. Substations are important part of power system and form a link between generating stations, transmission systems and distribution systems. It is an assembly of electrical components such as bus-bars, switchgear apparatus, power transformers etc.

Their main functions are to receive power transmitted at high voltage from the generating stations and reduce the voltage to a value suitable for distribution. Some substations provide facilities for switching operations of transmission lines, others are converting stations. Substations are provided with safety devices to disconnect equipment or circuit at the time of faults. Substations are the convenient place for installing synchronous condensers for the purpose of improving power factor and it provide facilities for making measurements to monitor the operation of the various parts of the power system.

The substations may be classified in according to service requirements and constructional features. According to service requirements it is classified in to transformer substations, switching substations and converting substations.

The present-day electrical power system is a.c. i.e. electric power is generated, transmitted and distributed in the form of alternating current. The electric power is produced at the power stations which are located at favourable places, generally quite away from the consumers. It is delivered to the consumers through a large network of transmission and distribution. At many places in the line of the power system, it may be desirable and necessary to change some

Characteristic (e.g. voltage, a.c to d.c., frequency, p.f etc.) of electric supply. This is accomplished by suitable apparatus called sub-station. For example, generation voltage (11 kV or 6.6 kV) at the power station is stepped up to high voltage (say 220 kV or 132 kV) for transmission of electric power. The assembly of apparatus (e.g. transformer etc.) used for this purpose is the sub-station. Similarly, near the consumers localities, the voltage may have to be stepped down to utilization level. This job is again accomplished by a suitable apparatus called sub-station.

Yet at some places in the line of the power system, it may be desirable to convert large quantities of a.c. power to d.c power e.g. for traction, electroplating, d.c motors etc. This job is again performed by suitable apparatus (e.g ignitron) called sub-station. It is clear that type of equipment needed in a sub-station will depend upon the service requirement. Although there can be several types of sub-stations, we shall mainly confine our attention to only those sub-stations where the incoming and outgoing supplies are a.c. i.e. sub-stations which change the voltage level of the electric supply.

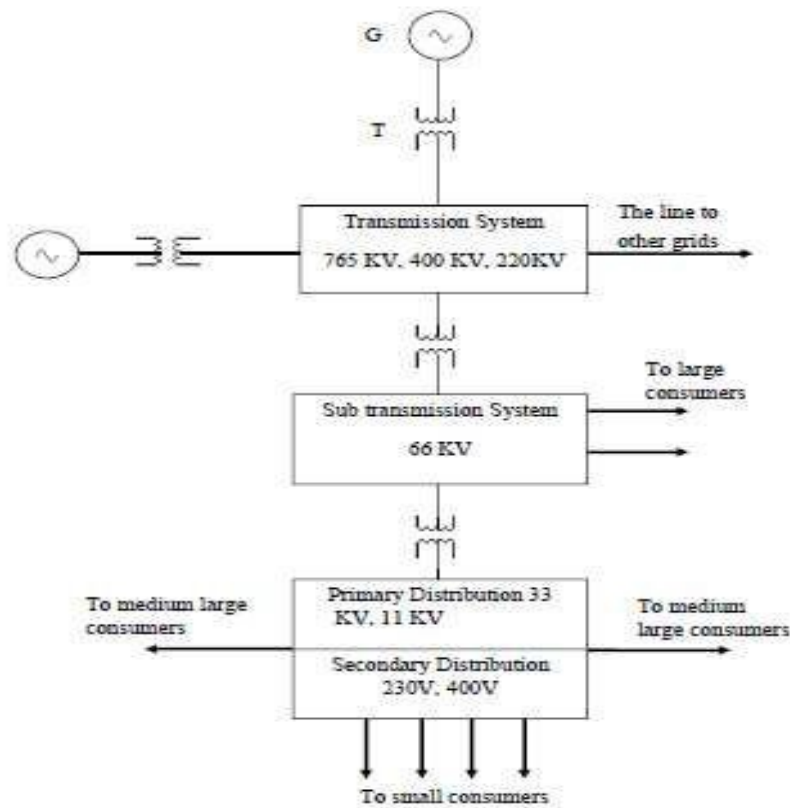
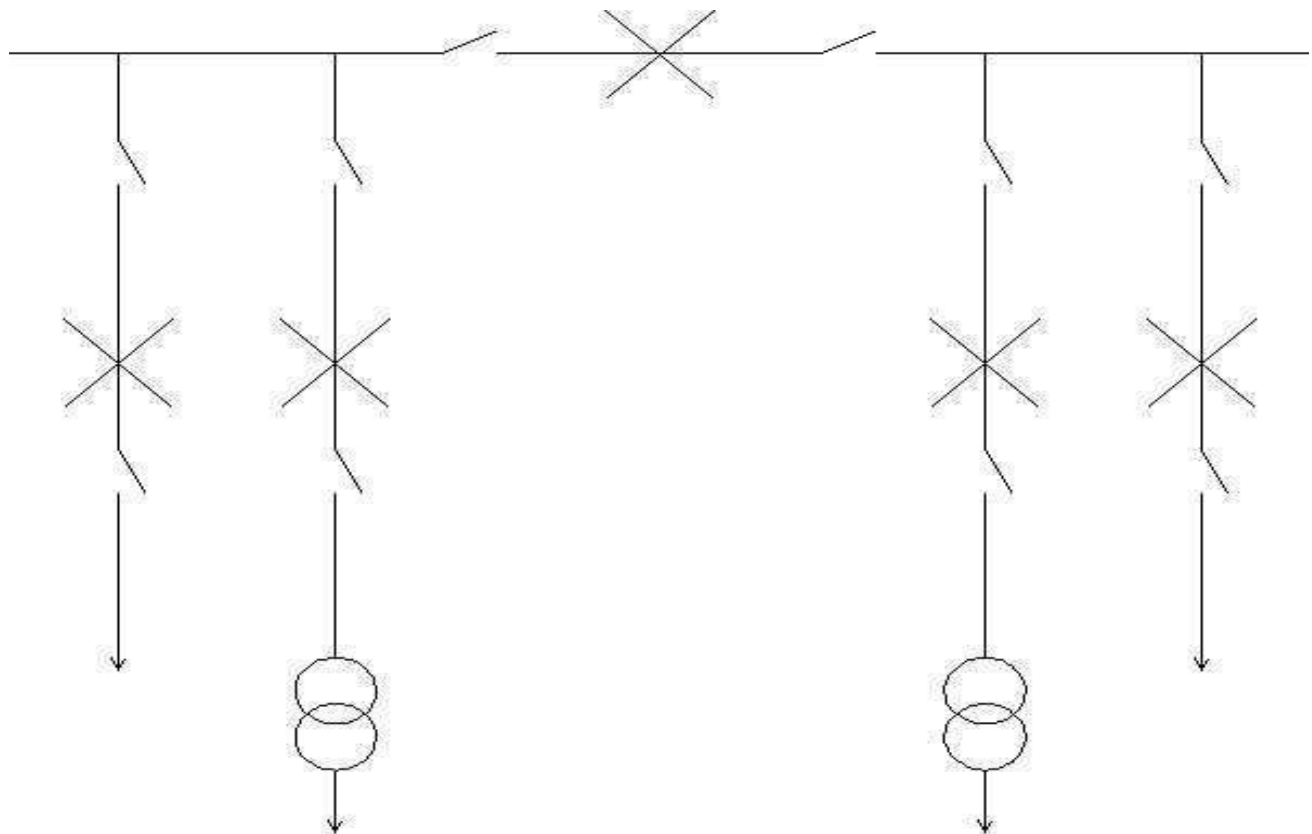

Figure 1.1 Single line Power System Network

Types of Substations:

1. Single Busbar:

The general schematic for such a substation is shown in the figure below.



With this design, there is an ease of operation of the substation. This design also places minimum reliance on signalling for satisfactory operation of protection. Additionally there is the facility to support the economical operation of future feeder bays.

Such a substation has the following characteristics.

Each circuit is protected by its own circuit breaker and hence plant outage does not necessarily result in loss of supply.

A fault on the feeder or transformer circuit breaker causes loss of the transformer and feeder circuit, one of which may be restored after isolating the faulty circuit breaker.

A fault on the bus section circuit breaker causes complete shutdown of the substation. All circuits may be restored after isolating the faulty circuit breaker. A busbar fault causes loss of one transformer and one feeder.

Maintenance of one busbar section or isolator will cause the temporary outage of two circuits.

Maintenance of a feeder or transformer circuit breaker involves loss of the circuit. Introduction of bypass isolators between busbar and circuit isolator allows circuit breaker maintenance facilities without loss of that circuit.

2. Mesh Substation:

The general layout for a full mesh substation is shown in the schematic below.

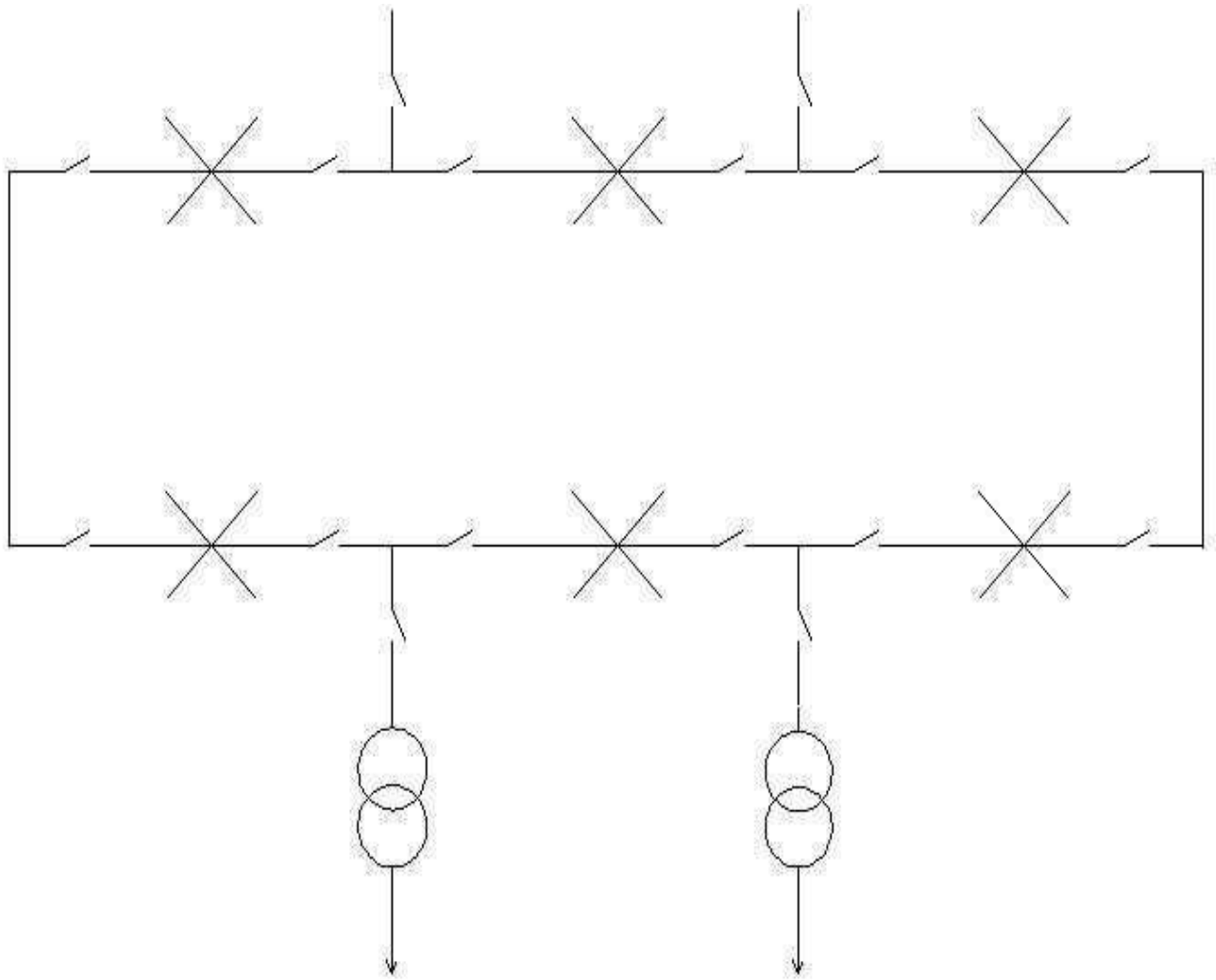

The characteristics of such a substation are as follows.

Operation of two circuit breakers is required to connect or disconnect a circuit, and disconnection involves opening of a mesh. Circuit breakers may be maintained without loss of supply or protection, and no additional bypass facilities are required. Busbar faults will only cause the loss of one circuit breaker. Breaker faults will involve the loss of a maximum of two circuits. Generally, not more than twice as many outgoing circuits as in feeds are used in order to rationalize circuit equipment load capabilities and ratings.

3. One and a half Circuit Breaker layout:

The layout of a 1 1/2 circuit breaker substation is shown in the schematic below.

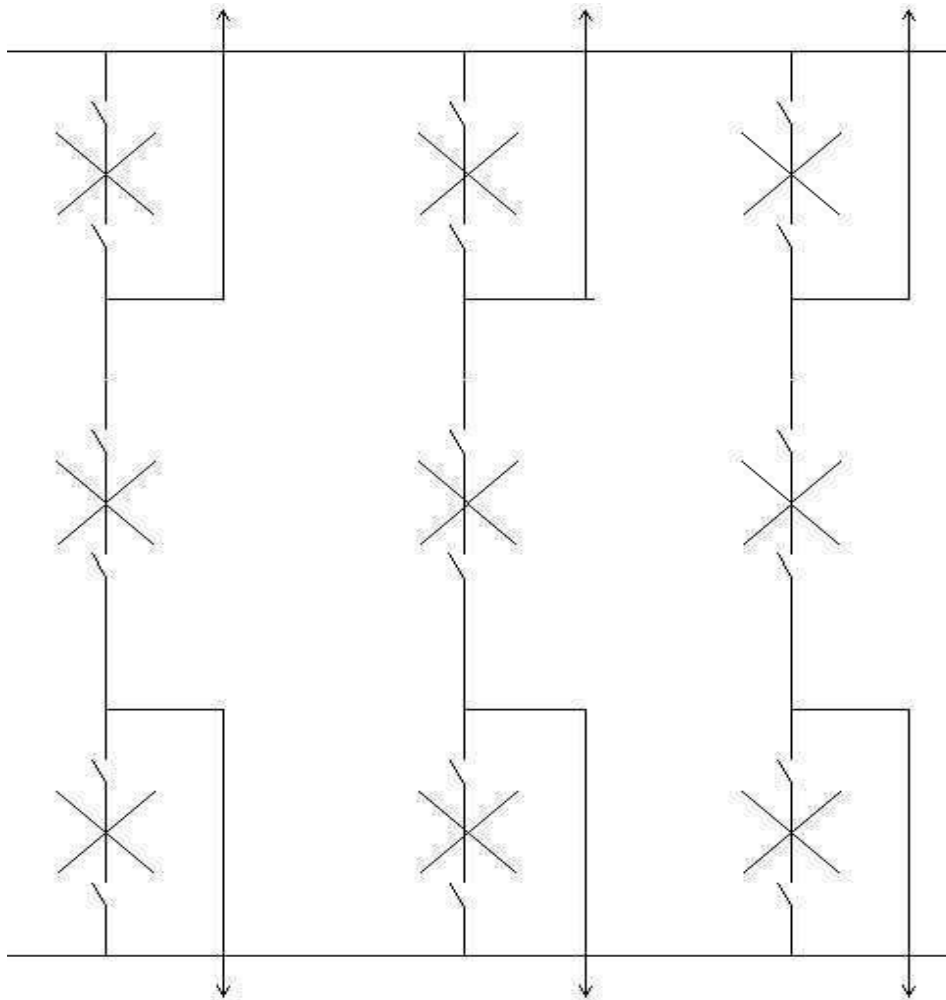

The reason that such a layout is known as a 1 1/2 circuit breaker is due to the fact that in the design, there are 9 circuit breakers that are used to protect the 6 feeders. Thus, 1 1/2 circuit breakers protect 1 feeder. Some characteristics of this design are:

There is the additional cost of the circuit breakers together with the complex arrangement. It is possible to operate any one pair of circuits, or groups of pairs of circuits. There is a very high security against the loss of supply.

4. Main and Auxiliary bus bar:

This is technically a single bus bar arrangement with an additional bus bar called “Auxiliary bus” energized from main bus bars through a bus coupler circuit, i.e., for ‘n’ number of circuits, it employs ‘n + 1’ circuit breakers. Each circuit is connected

to the main bus bar through a circuit breaker with isolators on both sides and can be connected to the auxiliary bus bar through an isolator. The additional provision of bus coupler circuit (Auxiliary bus) facilitates taking out one circuit breaker at a time for routine overhaul and maintenance without de-energizing the circuit controlled by that breaker as that circuit then gets energized through bus coupler breaker. As in the case of single bus arrangement, this scheme also suffers from the disadvantages that in the event of a fault on the main bus bar or the associated isolator, the entire substation is lost. This bus arrangement has been extensively used in 132 kV Sub Stations.

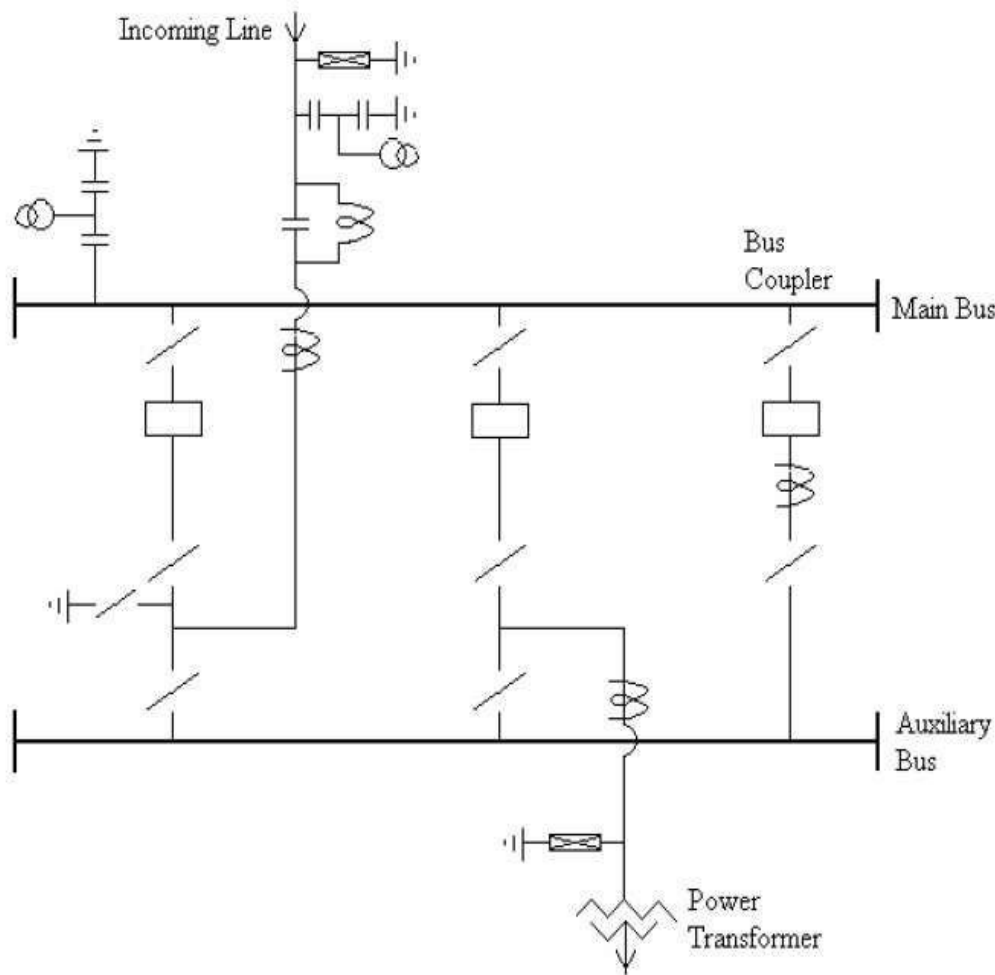

TYPICAL MAIN AND AUXILIARY BUS BAR ARRANGEMENT

5. Double bus bar:

In this scheme, a double bus bar arrangement is provided. Each circuit can be connected to either one of these bus bars through respective bus bar isolator. Bus coupler breaker is also provided so that the circuits can be switched on from one bus to the other on load. This scheme suffers from the disadvantage that when any circuit breaker is taken out for maintenance, the associated feeder has to be shut down. This Bus bar arrangement was generally used in earlier 220 kV sub stations.

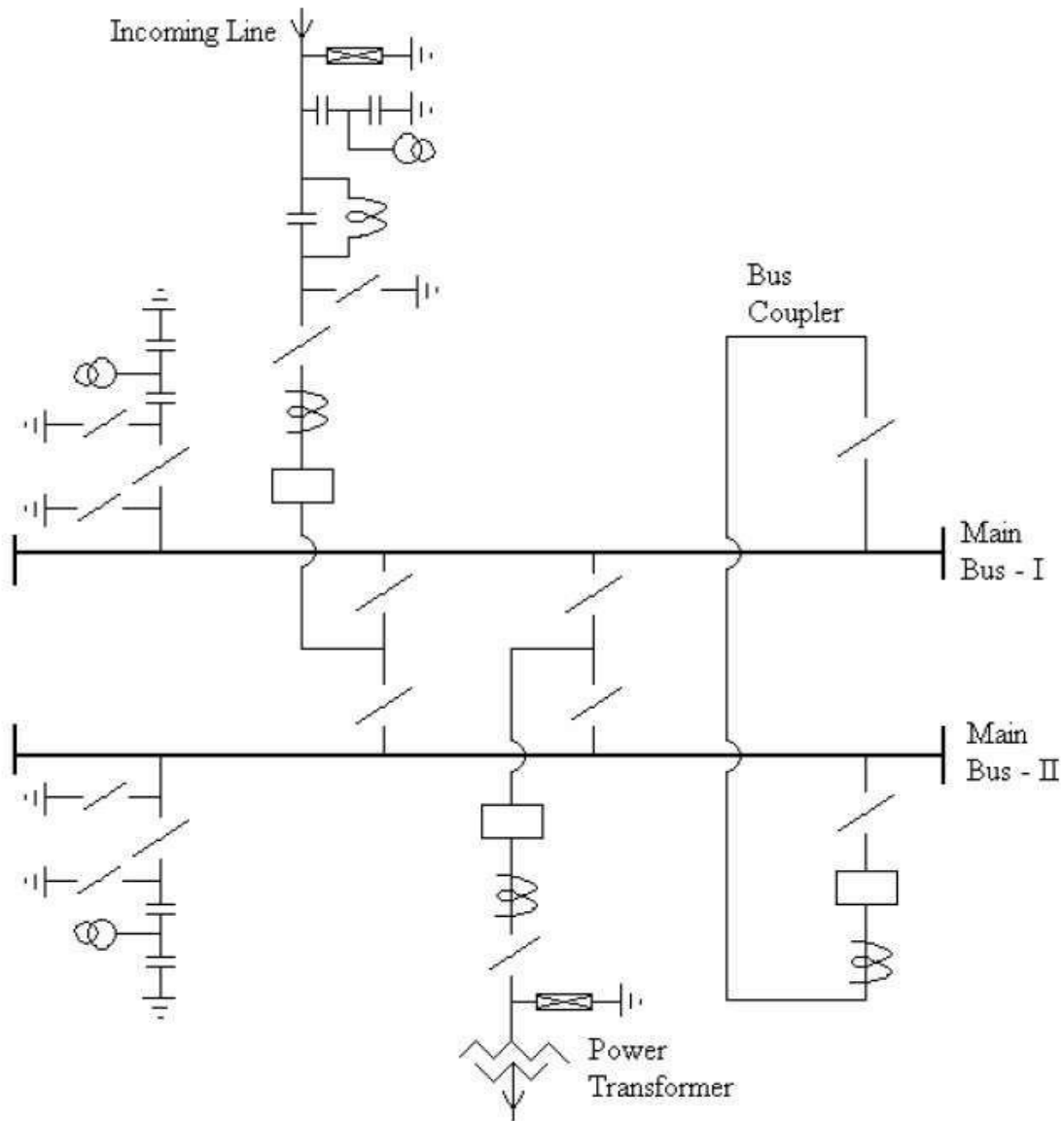

TYPICAL DOUBLE BUS BAR ARRANGEMENT

6. Double Main and Auxiliary bus bar:

The limitation of double bus bar scheme can be overcome by using additional Auxiliary bus, bus coupler breaker and Auxiliary bus isolators. The feeder is transferred to the Auxiliary bus during maintenance of its controlling circuit breaker without affecting the other circuits. This Bus bar arrangement is generally used nowadays in 220 kV sub stations.

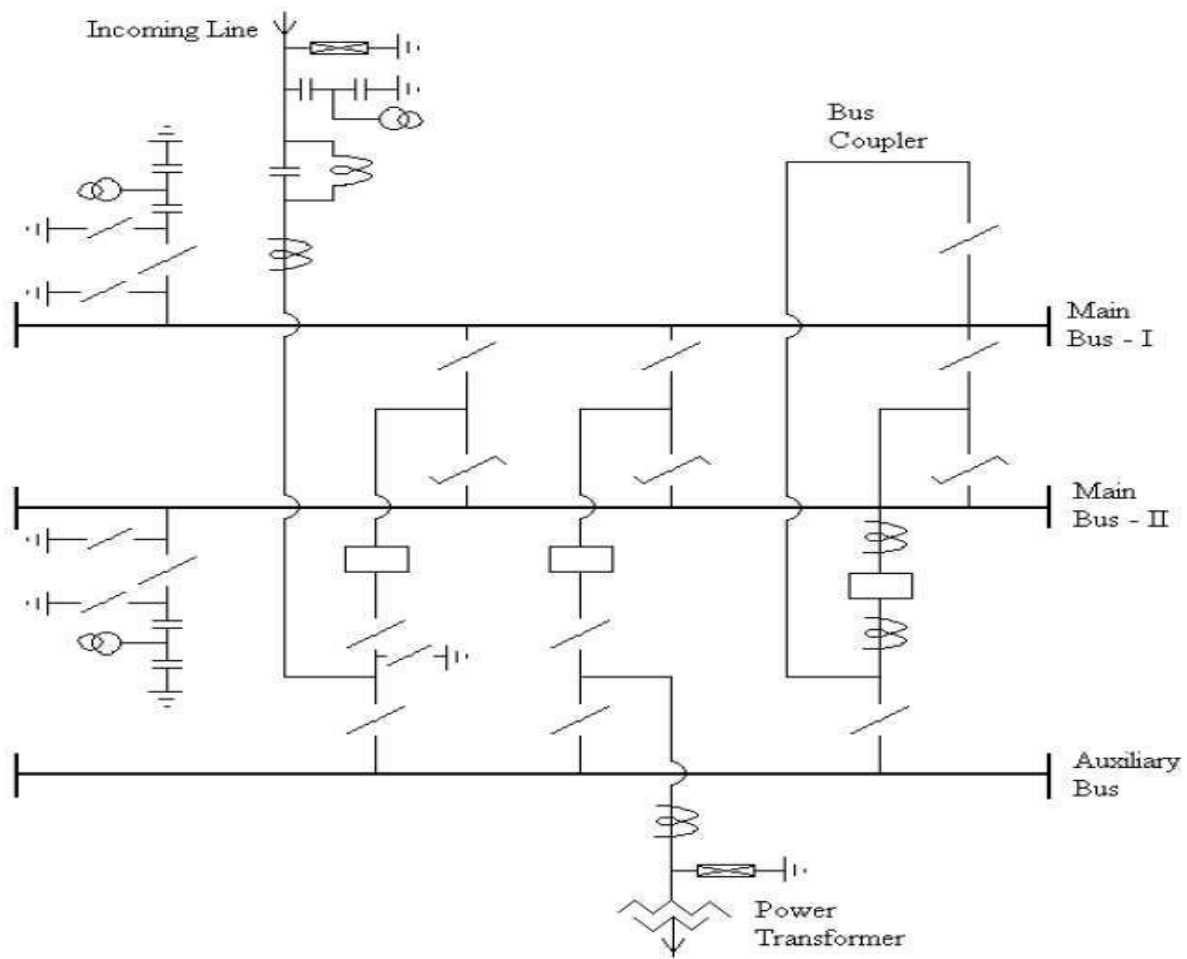

TYPICAL DOUBLE MAIN AND AUXILIARY BUS BAR ARRANGEMENT

Classification of sub-station

There are several ways of classifying sub-station. However the two most important way of classifying them are.

- According to service requirement
- According to constructional features

According to service requirement:

According to service requirement sub-station may be classified into.

1. Transformer sub-station

Those sub-station which change the voltage level of electrical supply are called TIF s/s.

2. Switching sub-station :

These sub-station simply perform the switching operation of power line.

3. Power factor correction S/S :

These sub-station which improve the p.f. of the system are called p.f. correction s/s. these are generally located at receiving end s/s.

4. Frequency changer S/S :

Those sub-stations, which change the supply frequency, are known as frequency changer s/s. Such s/s may be required for industrial utilization

5. Converting sub-station :

Those sub-station which change a.c. power into d.c. power are called converting s/s
ignition is used to convert AC to dc power for traction, electroplating, electrical welding etc.

6. Industrial sub-station:

Those sub-stations, which supply power to individual industrial concerns, are known as industrial sub-station.

According to constructional features :

According to constructional features, the sub-station are classified as :

1) Outdoor Sub-Station :-

For voltage beyond 66KV, equipment is invariably installed outdoor. It is because for such Voltage the clearances between conductor and the space required for switches, C.B. and other equipment becomes so great that it is not economical to installed the equipment indoor.

2)Indoor Sub-station :-

For voltage upto 11KV, the equipment of the s/s is installed indoor because of economic consideration. However, when the atmosphere is contaminated with impurities, these sub-stations can be erected for voltage upto 66KV

3) Underground sub-station :-

In thickly populated areas, the space available for equipment and building is limited and the cost of the land is high. Under such situations, the sub-station is created underground. The design of underground s/s requires more careful consideration.

- The size of the s/s should be as minimum as possible.
- There should be reasonable access for both equipment & personal.
- There should be provision for emergency lighting and protection against fire.
- There should be good ventilation

4) Pole-mounted sub-station:-

This is an outdoor sub-station with equipment installed overhead on H.pole or 4-pole structure. It is the cheapest form of s/s for voltage not exceeding 11KV (or 33KV in some cases). Electric power is almost distributed in localities through such sub-station. The 11KV line is connected to the T/F (11KV/440V) through gang isolator and fuses. The lightning arresters are installed on the H.T. Side to protect the sub-station from lightning strokes. The T/F step down

voltage to 400 V, 3 phase, 4 wire supply. The voltage between any two lines is 400 V & between line & neutral is 230V. The oil ckt breaker installed on the L.T. side automatically isolates the mounted sub-station. T/F are generally in the event of fault generally 200KVA T/F is used.

SUBSTATION PARTS AND EQUIPMENTS

Each sub-station has the following parts and equipment.

1. Outdoor Switchyard
 - Incoming Lines
 - Outgoing Lines
 - Bus bar
 - Transformers
 - Bus post insulator & string insulators
 - Substation Equipment such as Circuit-breakers, Isolators, Earthing Switches, Surge Arresters, CTs, VTs, Neutral Grounding equipment.
 - Station Earthing system comprising ground mat, risers, auxiliary mat, earthing strips, earthing spikes & earth electrodes.
 - Overhead earth wire shielding against lightening strokes.
 - Galvanised steel structures for towers, gantries, equipment supports.
 - PLCC equipment including line trap, tuning Module, coupling capacitor, etc.
 - Power cables
 - Control cables for protection and control
 - Roads, Railway track, cable trenches
 - Station illumination system
2. Main Office Building
 - Administrative building
 - Conference room etc.
3. 6/10/11/20/35 KV Switchgear, LV
 - Indoor Switchgear
4. Switchgear and Control Panel Building
 - Low voltage a.c. Switchgear

- Control Panels, Protection Panels
5. Battery Room and D.C. Distribution System
 - D.C. Battery system and charging equipment
 - D.C. distribution system
 6. Mechanical, Electrical and Other Auxiliaries
 - Fire fighting system
 - D.G. Set
 - Oil purification system

An important function performed by a substation is switching, which is the connecting and disconnecting of transmission lines or other components to and from the system. Switching events may be “planned” or “unplanned”. A transmission line or other component may need to be de energized for maintenance or for new construction; for example, adding or removing a transmission line or a transformer. To maintain reliability of supply, no company ever brings down its whole system for maintenance. All work to be performed, from routine testing to adding entirely new substations, must be done while keeping the whole system running.

Perhaps more importantly, a fault may develop in a transmission line or any other component. Some examples of this: a line is hit by lightning and develops an arc, or a tower is blown down by a high wind. The function of the substation is to isolate the faulted portion of the system in the shortest possible time.

There are two main reasons: a fault tends to cause equipment damage; and it tends to destabilize the whole system. For example, a transmission line left in a faulted condition will eventually burn down, and similarly, a transformer left in a faulted condition will eventually blow up. While these are happening, the power drain makes the system more unstable. Disconnecting the faulted component, quickly, tends to minimize both of these problems.

Selection and location of site for substation:

Voltage levels, voltage regulation, the cost of sub transmission, substation, primary feeder mains and distribution transformers dictate the location of a substation. However, the following rules are to be considered for the selection of an ideal location for a substation:

- The substation should be located nearer the load centre of its service areas, so that its distance from the substation is minimum.
- Proper voltage regulation should be possible without taking extensive measures.

- There should be proper access for incoming sub-transmission lines and outgoing primary feeders.
- It should provide enough space for future expansion.
- It should help minimize the number of customers affected by any service interruption.

The following factors are considered while making site selection for a substation

1. Type of substation: The category substation is important for its location. For example a step-up substation, which is generally a point where power from various sources (generating machines or generating stations) is pooled and stepped up for long distance transmission, should be located as close to the generating stations as possible to minimize the transmission losses. Similarly a step-down substation should be located nearer to the load centre to reduce transmission losses, cost of distribution system and better reliability of supply.

2. Availability of suitable and sufficient land: The land proposed for a substation should be normally level and open from all sides. It should not be water logged particularly in rainy season. According to the latest practice the land required for various types of Substations is given below:

Type of Substation	Area Required
i. 400 kV substation	50 acres
ii. 220 kV substation	25 acres
iii. 132 kV substation	10 acres

3. Communication facility: Suitable communication facility is desirable at a proposed substation both during and after its construction. It is better, therefore, to select the site alongside on existing road to facilitate an easier and cheaper transportation.





4. Atmospheric pollution: atmosphere around factories, which, may produce metal corroding gases, air fumes, conductive dust etc., and nearer sea coasts, where air may be more humid and may be salt laden, is detrimental to the proper running of power system and

therefore substations should not be located near factories or sea coast.

5. Availability of essential amenities to the staff: The site should be such where staff can be provided essential amenities like school, hospital, drinking water, housing etc.

6. Drainage facility: The site selected for the proposed substation should have proper drainage arrangement or possibility of making effective drainage arrangement to avoid pollution of air and growth of micro-organisms detrimental to equipment and health.

Key diagram of typical substations:

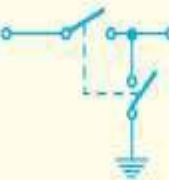
S.No.	Circuit element	Symbol
1	Bus-bar	
2	Single-break isolating switch	
3	Double-break isolating switch	
4	On load isolating switch	
5	Isolating switch with earth Blade	

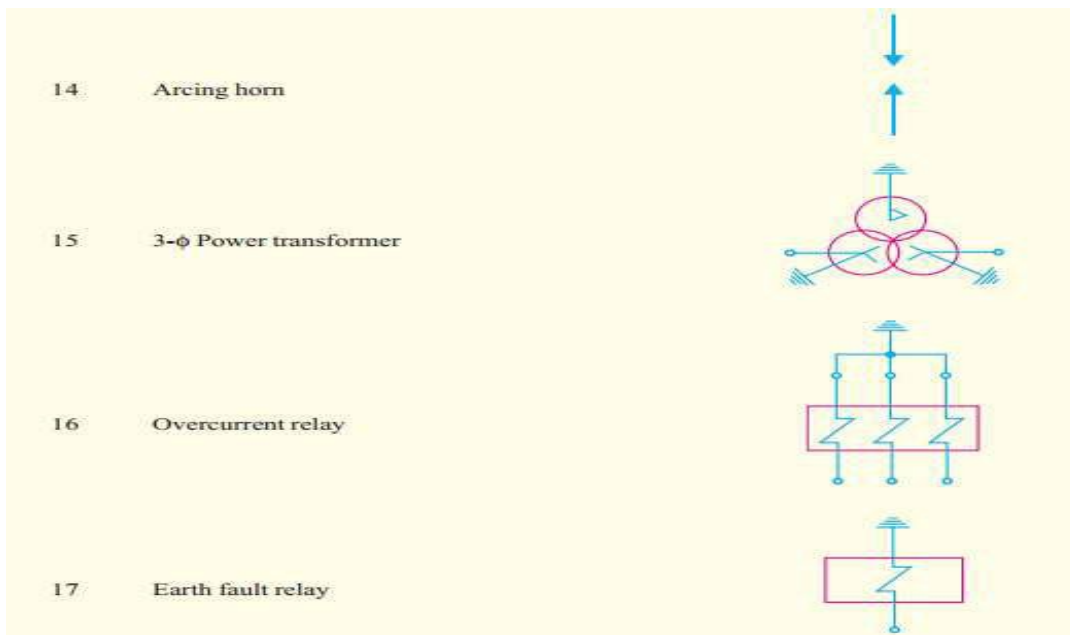
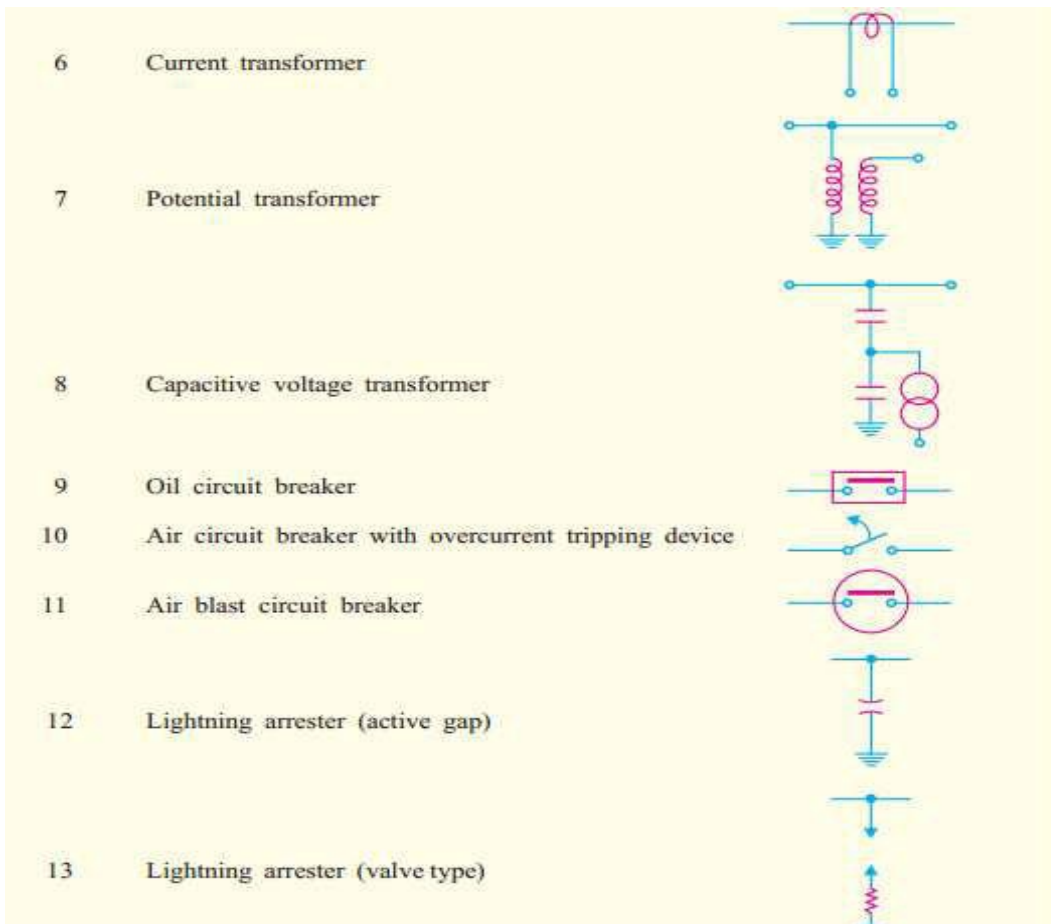

Key diagram of typical substations:

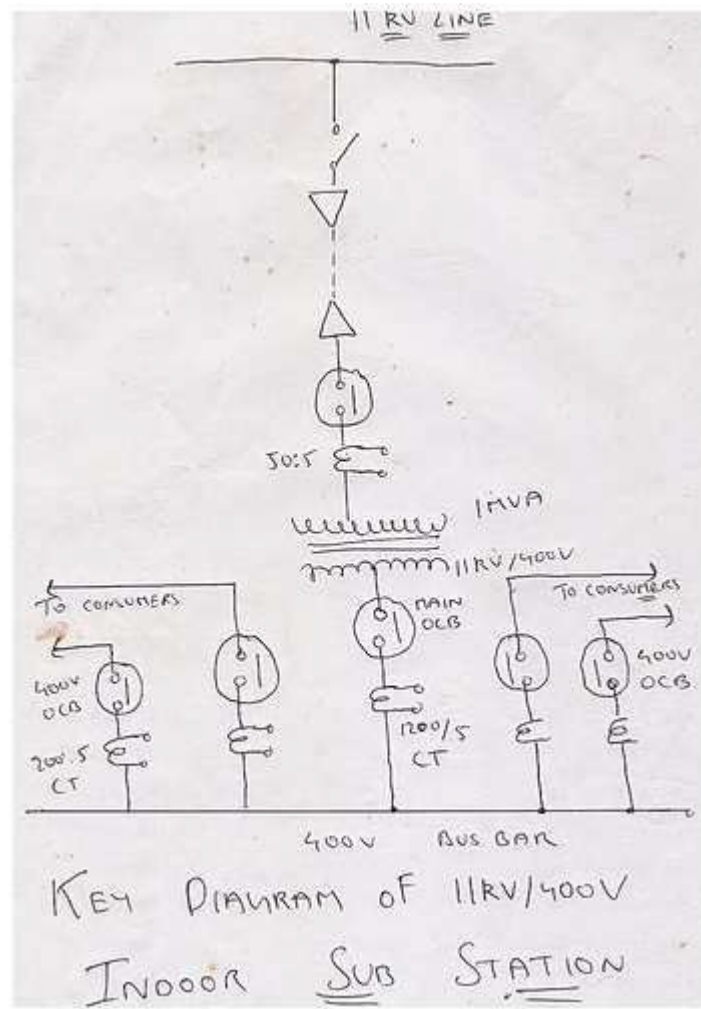

(i) The 3-phase, 3-wire 11 kV line is tapped and brought to the gang operating switch installed near the sub-station. The G.O. switch consists of isolators connected in each phase of the 3-phase line.

(ii) From the G.O. switch, the 11 kV line is brought to the indoor sub-station as underground cable. It is fed to the H.T. side of the transformer (11 kV/400 V) via the 11 kV O.C.B. The transformer steps down the voltage to 400 V, 3-phase, 4-wire.

(iii) The secondary of transformer supplies to the bus-bars via the main O.C.B. From the busbars, 400 V, 3-phase, 4-wire supply is given to the various consumers via 400 V O.C.B. The voltage

between any two phases is 400 V and between any phase and neutral it is 230 V. The single phase residential load is connected between any one phase and neutral whereas 3- phase, 400 V motor load is connected across 3-phase lines directly.

(iv) The CTs are located at suitable places in the sub-station circuit and supply for the metering and indicating instruments and relay circuits

Equipment for substation and switchgear installations:

In an electric power system, switchgear is the combination of electrical disconnect switches, fuses or circuit breakers used to control, protect and isolate electrical equipment. Switchgear is used both to de-energize equipment to allow work to be done and to clear faults downstream. This type of equipment is directly linked to the reliability of the electricity supply.

The very earliest central power stations used simple open knife switches, mounted on insulating panels of marble or asbestos. Power levels and voltages rapidly escalated, making opening manually operated switches too dangerous for anything other than isolation of a de-energized circuit. Oil-filled equipment allowed arc energy to be contained and safely controlled. By the early 20th century, a switchgear line-up would be a metal-enclosed structure with electrically operated switching elements, using oil circuit breakers. Today, oil-filled equipment has largely been replaced by air-blast, vacuum, or SF₆ equipment, allowing large currents and power levels to be safely controlled by automatic equipment incorporating digital controls, protection, metering and communications.

High voltage switchgear was invented at the end of the 19th century for operating motors and other electric machines. The technology has been improved over time and can be used with voltages up to 1,100 kV.

Typically, the switchgear in substations is located on both the high voltage and the low voltage side of large power transformers. The switchgear on the low voltage side of the transformers may be located in a building, with medium-voltage circuit breakers for distribution circuits, along with metering, control, and protection equipment. For industrial applications, a transformer and switchgear line-up may be combined in one housing, called a Moduleized substation or USS.

Substation auxiliaries supply:

All but the smallest substations include auxiliary power supplies. AC power is required for substation building small power, lighting, heating and ventilation, some communications equipment, switchgear operating mechanisms, anti-condensation heaters and motors. DC power is used to feed essential services such as circuit breaker trip coils and associated relays, supervisory control and data acquisition (SCADA) and communications equipment. This chapter describes how these auxiliary supplies are derived and explains how to specify such equipment.

Substation Earthing:

Earthing systems are provided in a substation for the following main reasons:

- To provide a discharge path for lightning arrests, gaps, etc.
- To provide proper grounding for substation equipments.
- To keep the non-current carrying metal parts, such as transformer tank, structures, etc., safe at earth potential even though the insulation fails.

The fault current through the neutral of the transformer to earth is to be distributed over a large area; otherwise the potential gradient of the earth around the earth connection may be dangerous. Earth mat consisting of heavy gauge-bonded conductors or cast iron grid buried at a depth of not less than 30 cm and connected to the earth electrode, serves best to distribute the heavy fault current over a large earth area. For small stations, more number of earthing stations are provided at different places and are interconnected which helps to reduce the potential gradient.

BASIC TERMS OF EARTHING

Earth : An object is said to be earthed when it is electrically connected to an earth electrode. A conductor is said to be solidly earthed when it is electrically connected to an earth electrode without intentional addition of resistance or impedance in the earth connection.

Earth Electrode : A metal plate, pipe, any other conductor or an array of conductors electrically connected to the general mass of the earth.

Earthing Lead: The conductor by which the earth electrode is connected to neutral is called earthing lead.

GROUNDING OR NEUTRAL EARTHING:

The word “earthing” and “grounding” have the same meaning. But equipment earthing is different from neutral-point earthing. Equipment earthing refers to connecting the non-current carrying metallic parts to earth available in the neighbourhood of electrical circuits. For example: motor body, switch gear, Transformer tank, etc.

Thus, the purpose of neutral earthing and that of equipment earthing are distinctly different. Equipment earthing ensures safety while neutral earthing is done mostly to ensure that the stator short-circuit current is limited and for stability reasons.

The very purpose of earthing is to safeguard the equipment against possible damage due to electric shock, fire, etc. It is very important to have good and effective earthing or grounding. Today, the neutral grounding is an important aspect of power-system designs because the performance of the system, in terms of short circuits, stability, protection, etc., is greatly affected by the state of the neutral. In most of the modern high-voltage systems, the neutral of the system is solidly grounded, i.e., the neutral is connected directly to the ground.

METHODS OF NEUTRAL GROUNDING

The various methods of grounding the neutral of the system are:

1. Solid grounding
2. Resistance grounding
3. Reactance grounding
4. Peterson-coil grounding (or resonant grounding)
5. Voltage transformer grounding
6. Earthed transformer

SOLID GROUNDING OR EFFECTIVE GROUNDING:

The term effective grounding is the same as solid grounding. The neutral is directly connected to ground without any impedance between neutral and ground as shown in Fig.1 below

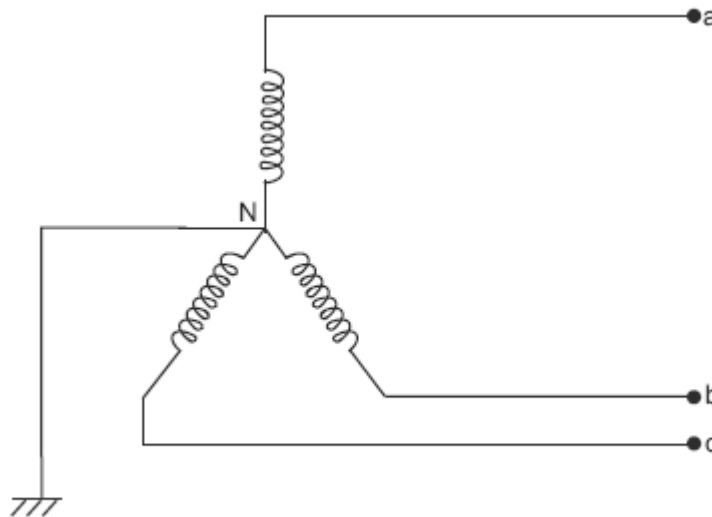

Fig. 13.13 Solidly grounded system

Consider a line to ground fault on any one phase, say phase 'a' at a point F as shown in fig 2. As a result of this fault, the line to neutral voltage of phase 'a' becomes zero, but the phase to the earth voltage of the remaining two healthy phases will be approximately constant.

GROUNDING GRID:

Grounding grids are used where there is a chance of flow of large fault currents through the system. A grounding grid is composed of a number of rods that are joined together through copper conductors to reduce the overall grounding resistance. They are also known as earthing mats or earthing grids. This arrangement should be made near the ground surface as it limits the potential gradient. Driving rods deep into the soil, however, becomes an expensive process, especially in the case of hard soil or soils having low conductivity. The performance of a grounding grid system suffers when the rods are removed from the mesh.

The following factors have to be taken into account while designing a grounding grid:

- ❖ Voltage between the ground surface and the conductor should be kept at a minimum in

case of a fault.

MODULE – 5

ELECTRICAL INSTALLATION FOR POWER CIRCUITS:

Introduction:

Electrical wiring in general refers to insulated conductors used to carry electricity, and associated devices. This article describes general aspects of electrical wiring as used to provide power in buildings and structures, commonly referred to as building wiring. This article is intended to describe common features of electrical wiring that may apply worldwide. For information regarding specific national electrical codes, refer to the articles mentioned in the next section. Separate articles cover long-distance electric power transmission and electric power distribution.

Important considerations regarding motor installation wiring:

Electric motors are used in a wide variety of applications that affect our daily lives. Electric motors are the tools that use the alternating current (AC) power supplied to your home or shop by the power distribution company and transform it to mechanical energy to drive compressors, fans, tools, washing machines, garage door openers, and anything else that requires mechanical motion to operate. AC power is brought into your house or shop in 3 phases, each of them 120 volts AC when referred to an electrical neutral, but 120 electrical degrees out of phase with each other. Ground is different from the electrical neutral, and is provided only for protection from electric shock. Smaller motors are generally wired as 1 phase to neutral, providing them with single phase AC power. Larger motors are generally wired as 3 phase AC motors, using all 3 phases of incoming power and not connecting to the electrical neutral line. In addition, direct current (DC) motors can be used in battery power applications that do not have AC. All of these types of motors must be wired properly to perform the desired motion, and all are wired differently. Use these tips to learn how to wire an electric motor.

1. Check the voltage rating of the motor. The rated operating voltage will be listed on the nameplate of the motor. For example, a motor intended to run from a 12-volt car battery should be rated at 12 volts.

2. Determine the rotation. The motor faceplate will define which direction, clockwise or counter clockwise, the motor shaft will turn when the 2 motor wires are connected to the power source. The motor nameplate or manufacturer's information will specify which of the 2 motor wires should be connected to the positive side of the power source and which should be connected to the negative side of the power source to achieve the desired direction of rotation.

3. Establish the direction of motor rotation. Consult the motor nameplate or manufacturer's information for this information. That information should direct that 1 motor wire be attached to 1 (any 1) of the 3 power phases available and the other motor wire be attached to electrical neutral.

Count the motors being driven by the 3 phase input power in a line to neutral configuration. Attempt to balance the power being drawn from each of the 3 available phases so that the neutral line is carrying as little current as possible. A high neutral current can unbalance the power system and cause poor motor performance.

4. Wire the motor. Use wire strippers, available at hardware or electrical supply stores, to strip about half an inch (13 mm) of insulation from the end of the motor wire. Secure the motor wire under the screw termination available on the power distribution panel. Confirm that the motor rotates in the proper direction. If the motor does not rotate in the desired direction, the input leads may be swapped to reverse the motor direction of rotation.

Connect a 3 Phase AC Motor

Confirm that the motor is a 3 phase AC motor. This information will be on the motor faceplate. It also can be noted that the motor has 3 connecting wires, rather than 2. Confirm from the motor faceplate the operating voltage that the motor will require from the power distribution system.

2. Figure out the direction that the motor will turn. The motor nameplate and motor manufacturer's information should explain the needed wiring to make the motor turn in a particular direction.

3. Attach the motor power leads. Wire the 3 motor leads to the 3 phases of input power. Do not use the neutral line. If the motor does not turn in the desired direction, swap any 2 of the 3 motor wires to reverse the direction of rotation of the motor.

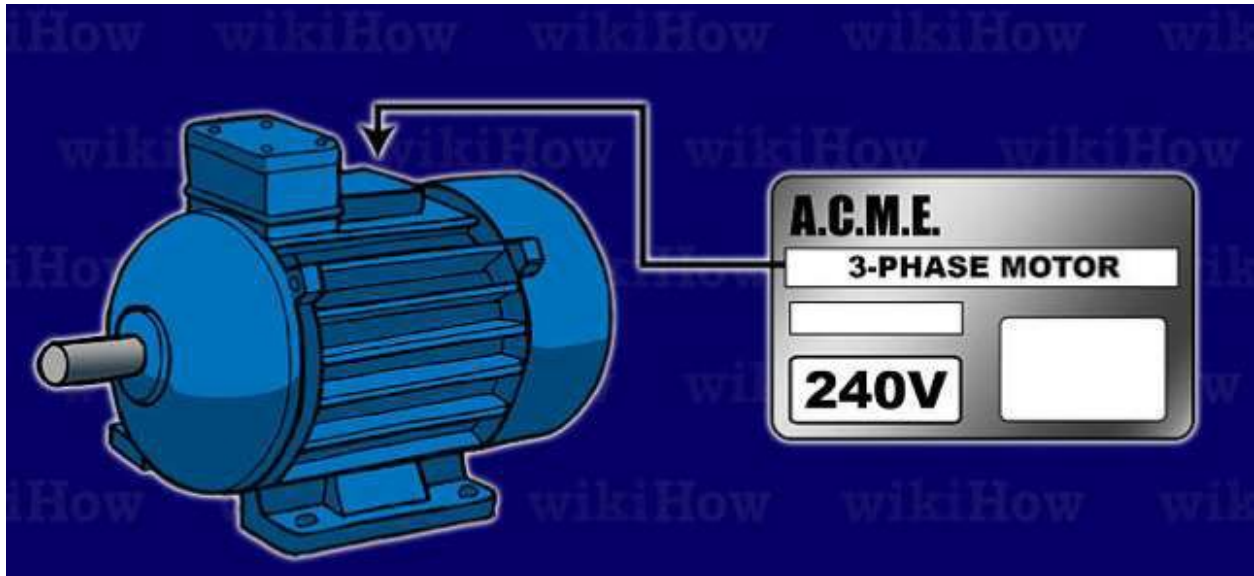

Determination of input power:

Reasons to Determine Motor Loading

Most electric motors are designed to run at 50% to 100% of rated load. Maximum efficiency is usually near 75% of rated load. Thus, a 10-horsepower (hp) motor has an acceptable load range of 5 to 10 hp; peak efficiency is at 7.5 hp. A motor's efficiency tends to decrease dramatically below about 50% load. However, the range of good efficiency varies with individual motors and tends to extend over a broader range for larger motors, as shown in Figure 1. A motor is considered under loaded when it is in the range where efficiency drops significantly with decreasing load. Figure 2 shows that power factor tends to drop off sooner, but less steeply than efficiency, as load decreases.

Figure 1 Motor Part-Load Efficiency (as a Function of % Full-Load Efficiency)

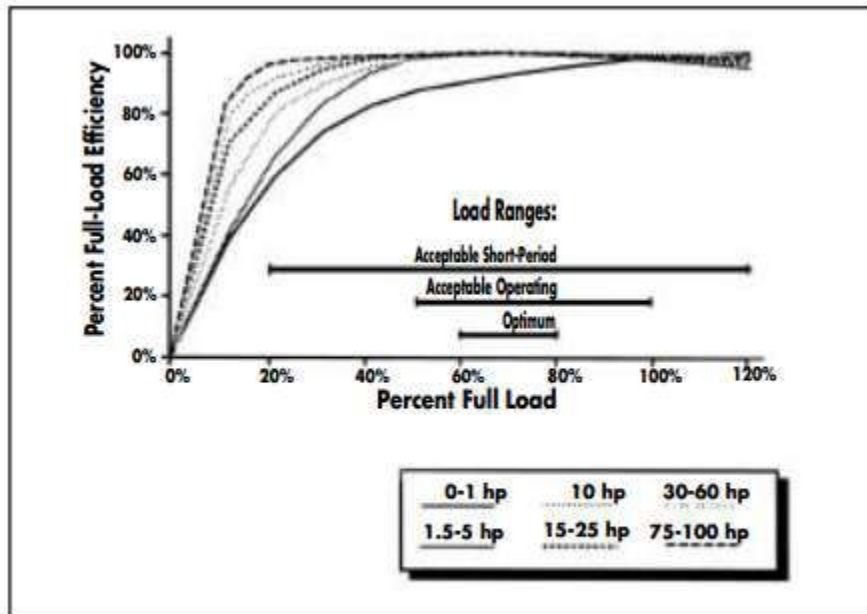

Figure 1 Motor Part-Load Efficiency (as a Function of % Full-Load Efficiency)

Determining Motor Loads

Input Power Measurements

When “direct-read” power measurements are available, use them to estimate motor part-load. With measured parameters taken from hand-held instruments, you can use Equation 1 to calculate the three-phase input power to the loaded motor. You can then quantify the motor’s part-load by comparing the measured input power under load to the power required when the motor operates at rated capacity. The relationship is shown in Equation 3.

Equation 1

$$P_i = \frac{V \times I \times PF \times \sqrt{3}}{1000}$$

Where:

- P_i = Three-phase power in kW
- V = RMS voltage, mean line-to-line of 3 phases
- I = RMS current, mean of 3 phases
- PF = Power factor as a decimal

Equation 2

$$P_{ir} = hp \times \frac{0.7457}{\eta_n}$$

Where:

- P_{ir} = Input power at full-rated load in kW
- hp = Nameplate rated horsepower
- η_n = Efficiency at full-rated load

Equation 3

$$Load = \frac{P_i}{P_{ir}} \times 100\%$$

Where:

- Load = Output power as a % of rated power
- P_i = Measured three-phase power in kW
- P_{ir} = Input power at full-rated load in kW

Determination of rating of cables: Cable

insulation materials

Rubber

For many years wiring cables were insulated with vulcanised natural rubber (VIR). Much cable of this type is still in service, although it is many years since it was last manufactured. Since the insulation is organic, it is subject to the normal ageing process, becoming hard and brittle. In this condition it will continue to give satisfactory service unless it is disturbed, when the rubber cracks and loses its insulating properties. It is advisable that wiring of this type which is still in service should be replaced by a more modern cable. Synthetic rubber compounds are used widely for insulation and sheathing of cables for flexible and for heavy duty applications. Many

variations are possible, with conductor temperature ratings from 60°C to 180°C, as well as resistance to oil, ozone and ultra-violet radiation depending on the formulation.

Paper

Dry paper is an excellent insulator but loses its insulating properties if it becomes wet. Dry paper is hygroscopic, that is, it absorbs moisture from the air. It must be sealed to ensure that there is no contact with the air. Because of this, paper insulated cables are sheathed with impervious materials, lead being the most common. PILC (paper insulated lead covered) is traditionally used for heavy power work. The paper insulation is impregnated with oil or non-draining compound to improve its long-term performance. Cables of this kind need special jointing methods to ensure that the insulation remains sealed. This difficulty, as well as the weight of the cable, has led to the widespread use of p.v.c. and XLPE (thermosetting) insulated cables in place of paper insulated types.

P.V.C.

Polyvinyl chloride (p.v.c.) is now the most usual low voltage cable insulation. It is clean to handle and is reasonably resistant to oils and other chemicals. When p.v.c. burns, it emits dense smoke and corrosive hydrogen chloride gas. The physical characteristics of the material change with temperature: when cold it becomes hard and difficult to strip, and so BS 7671 specifies that it should not be worked at temperatures below 5°C. However a special p.v.c. is available which remains flexible at temperatures down to -20°C.

At high temperatures the material becomes soft so that conductors which are pressing on the insulation (eg at bends) will 'migrate' through it, sometimes moving to the edge of the insulation. Because of this property the temperature of general purpose P.V.C. must not be allowed to exceed 70°C, although versions which will operate safely at temperatures up to 85°C are also available. If p.v.c. is exposed to sunlight it may be degraded by ultra-violet radiation. If it is in contact with absorbent materials, the plasticiser may be 'leached out' making the p.v.c. hard and brittle.

LSF (Low smoke and fume)

Materials which have reduced smoke and corrosive gas emissions in fire compared with p.v.c.

have been available for some years. They are normally used as sheathing compounds over XLPE or LSF insulation, and can give considerable safety advantages in situations where numbers of people may have to be evacuated in the event of fire.

Thermosetting (XLPE)

Gross-linked polyethylene (XLPE) is a thermosetting compound which has better electrical properties than p.v.c. and is therefore used for medium- and high-voltage applications. It has more resistance to deformation at higher temperatures than p.v.c., which it is gradually replacing. It is also replacing PILC in some applications. Thermosetting insulation may be used safely with conductor temperatures up to 90°C thus increasing the useful current rating, especially when ambient temperature is high. A LSF (low smoke and fume) type of thermosetting cable is available.

Mineral

Provided that it is kept dry, a mineral insulation such as magnesium oxide is an excellent insulator. Since it is hygroscopic (it absorbs moisture from the air) this insulation is kept sealed within a copper sheath. The resulting cable is totally fireproof and will operate at temperatures of up to 250°C. It is also entirely inorganic and thus non-ageing. These cables have small diameters compared with alternatives, great mechanical strength, are waterproof, resistant to radiation and electromagnetic pulses, are pliable and corrosion resistant. In cases where the copper sheath may corrode, the cable is used with an overall LSF covering, which reduces the temperature at which the cable may be allowed to operate. Since it is necessary to prevent the ingress of moisture, special seals are used to terminate cables. Special mineral-insulated cables with twisted cores to reduce the effect of electromagnetic interference are available.

Non-flexible low voltage cables

Types of cable currently satisfying the Regulations are shown in {Fig 4.1}.

a) Non-armoured pvc-insulated cables - Fig 4.1a

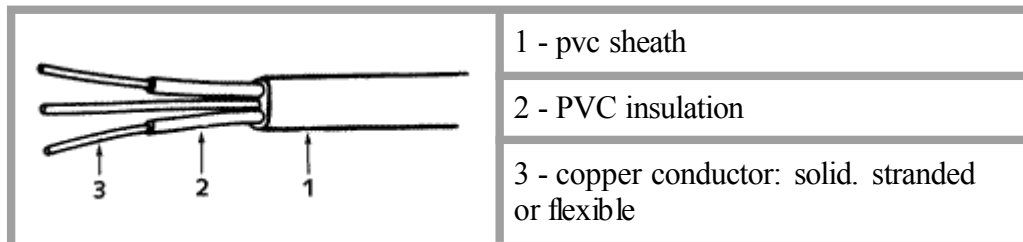

b) Armoured PVC-insulated cables - Fig 4.1b

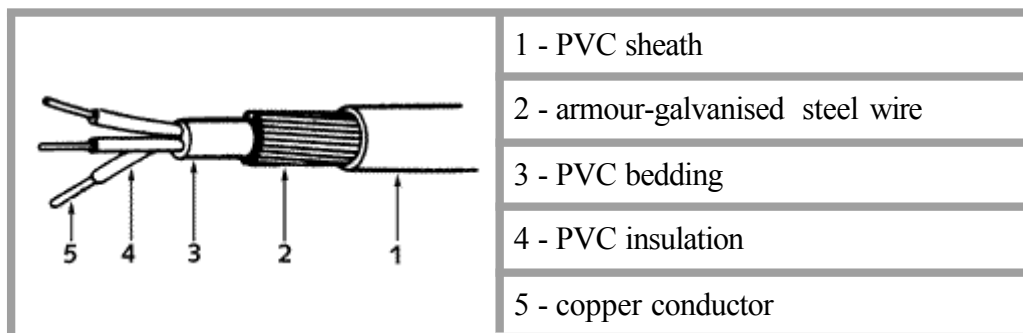

c) Split-concentric PVC insulated cables - Fig 4.1c

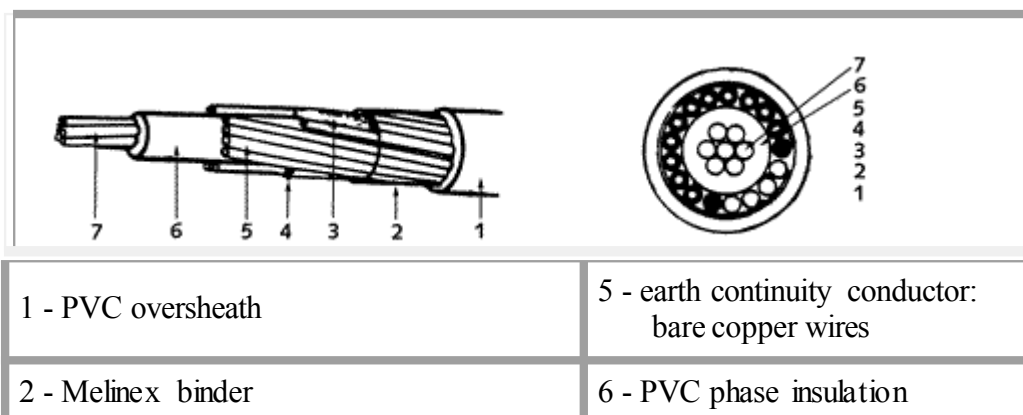

3 - PVC strings	7 - copper conductors
4 - neutral conductor: black PVC-covered wires	

d) Rubber-insulated (elastomeric) cables - Fig 4.1d

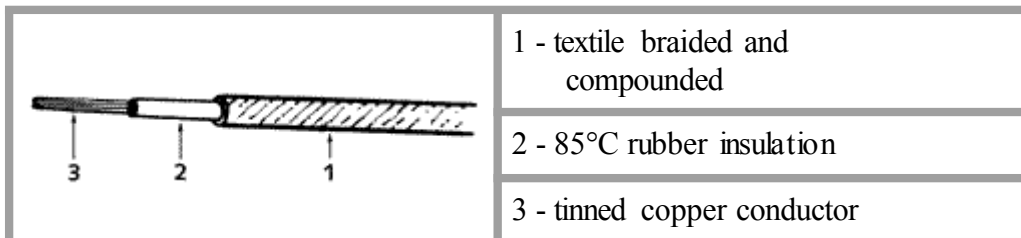

Flexible low voltage cables and cords

By definition flexible cables have conductors of cross-sectional area 4 mm² or greater, whilst flexible cords are sized at 4 mm² or smaller. Quite clearly, the electrician is nearly always concerned with flexible cords rather than flexible cables.

{Figure 4.2} shows some of the many types of flexible cords which are available.

a) Braided circular - Fig 4.2a

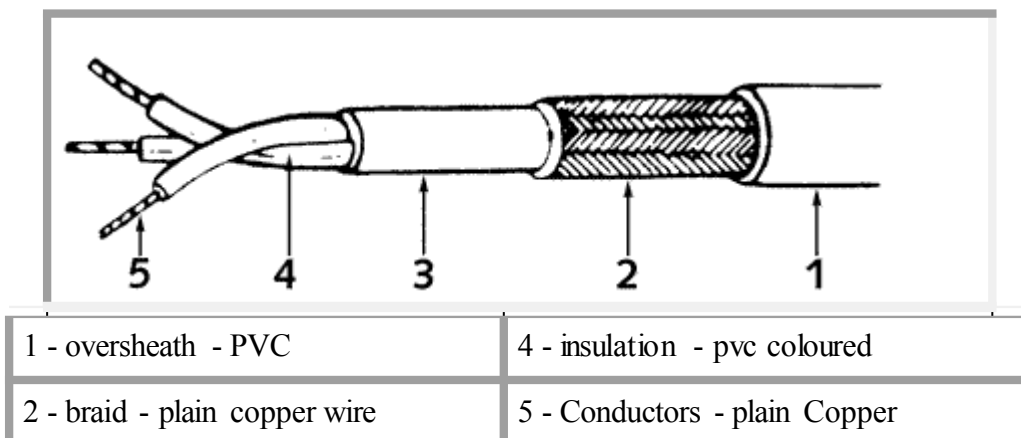

3 - inner sheath - pvc	
------------------------	--

b) Unkinkable - Fig 4.2b

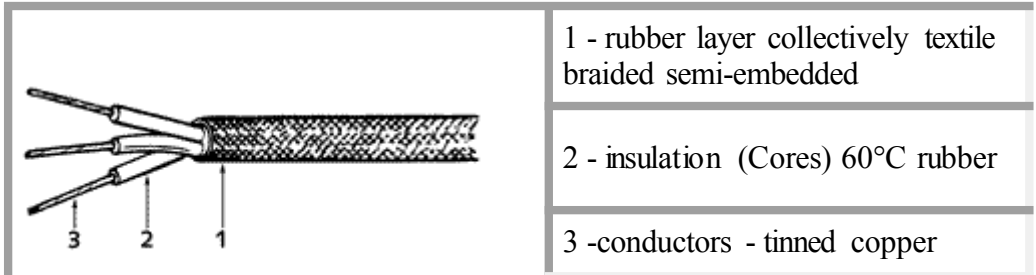

c) Circular sheathed - Fig 4.2c

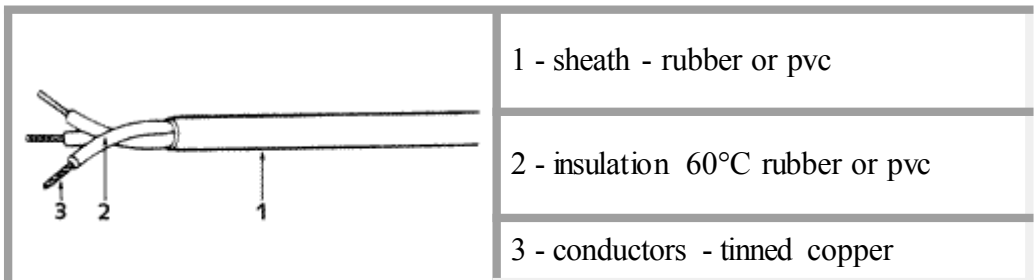

d) Flat twin sheathed - Fig 4.2d

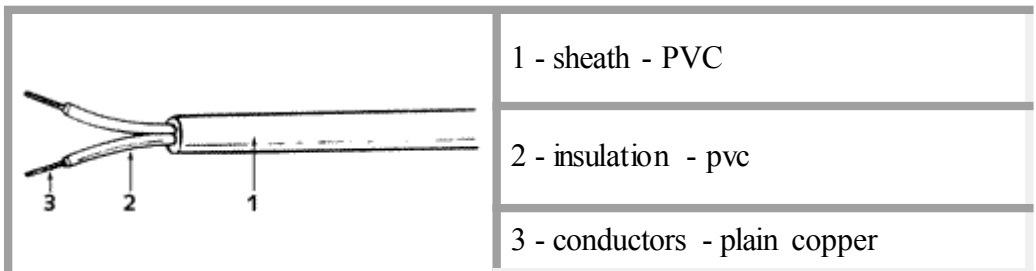

e) Braided circular insulated with glass fibre - Fig 4.2e



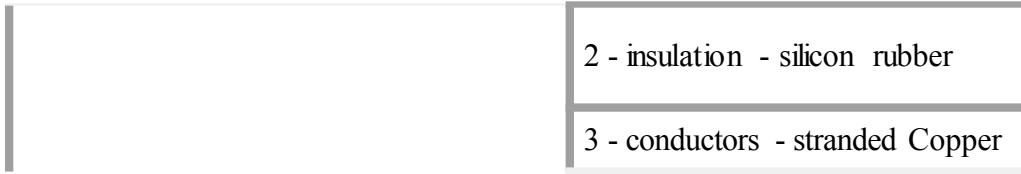

f) Single core p.v.c. - insulated non-sheathed - Fig 4.2f

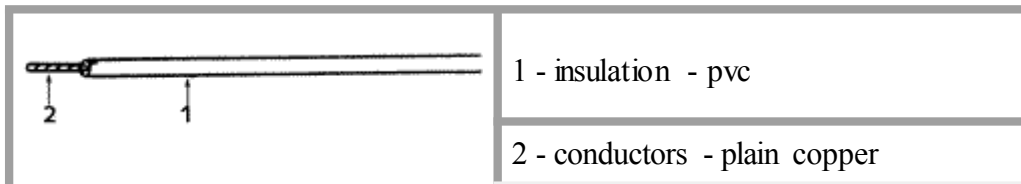

Flexible cables should not normally be used for fixed wiring, but if they are, they must be visible throughout their length. The maximum mass which can be supported by each flexible cord is listed in (Table 4H3A), part of which is shown here as (Table 4.2).

Table 4.2 - Maximum mass supported by twin flexible cord	
Cross-sectional area (mm ²)	Maximum mass to be supported (kg)
0.5	2
0.75	3
1.0	5
1.25	5
1.5	5

The temperature at the cord entry to luminaires is often very high, especially where filament lamps are used. It is important that the cable or flexible cord used for final entry is of a suitable heat resisting type, such as 150°C rubber- insulated and braided. (Fig 4.3) shows a short length of such cord used to make the final connection to a luminaire.

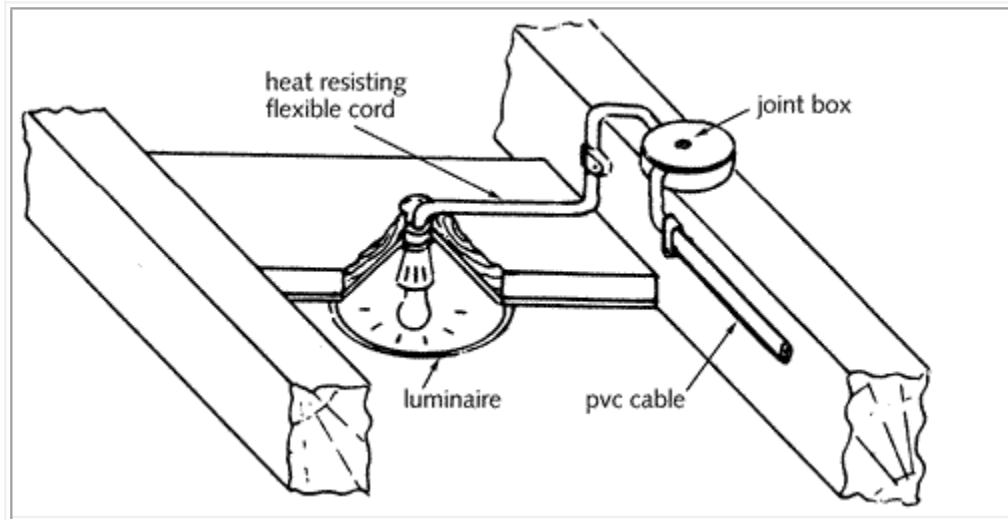

Fig 4.3 - 150°C rubber-insulated and braided flexible cord used for the final connection to a luminaire

Determination of rating of fuse:

The question of determining fuse size has been a common one lately so we decided to make a quick write up on choosing the correct fuse size. One common misconception about choosing the correct fuse size is that it's dependent the load of the circuit. Actually, the load of the circuit should have nothing to do with choosing a fuse size. The fuse size should be based on the SMALLEST wire (largest gage number) in the circuit. Here is how to correctly choose the right fuse size for your circuit.

- 1) Determine the wire gage you already have by locating it on the package or measuring it, you can also look at the topic this was posted in on Oznum forums for a step by step guide to finding the amperages for common products at the Oznum store.
- 2) Use the following table to determine the maximum current for whatever wire gage is being used.

The application guidelines and product data in this guide are intended to provide technical information that will help with application design. Since these are only a few of the contributing parameters, application testing is strongly recommended and should be used to verify performance in the circuit/application.

Many of the factors involved with fuse selection are listed below. For additional assistance with choosing fuses appropriate to your requirements, contact your Littelfuse products representative.

Selection Factors

1. Normal operating current
2. Application voltage (AC or DC)
3. Ambient temperature
4. Overload current and length of time in which the fuse must open
5. Maximum available fault current
6. Pulses, Surge Currents, Inrush Currents, Start-up Currents, and Circuit Transients
7. Physical size limitations, such as length, diameter, or height
8. Agency Approvals required, such as UL, CSA, VDE, METI, MITI or Military
9. Fuse features (mounting type/form factor, ease of removal, axial leads, visual indication, etc.)
10. Fuse holder features, if applicable and associated rerating (clips, mounting block, panel mount, PC board mount, R.F.I. shielded, etc.)
11. Application testing and verification prior to production

Distribution Board main switch and starter:

Power Distribution Board is a panel that has got fuses, circuit breakers and ground leakage protection components required to distribute electrical power to many individual circuits or end user points. It divides an electrical power feed into subsidiary circuits and provides protective fuse for each circuit placed within a common panel. It is through this main distribution board, the electricity is supplied to the Sub Main Distribution Board (SMDB) and electricity goes to the panels for further distribution.

Power Distribution Boards are common for most of the industrial or commercial electrical installations or for residential buildings. To have safe installation of electricity, it is important that the work gets done from the best technical house. Designing and building the electrical projects and implementing them flawlessly are not a small task that can get handled by any electrical company. Right technical expertise is needed to accomplish the job. To build the projects as per the requirements of the customers, innovative designs are to be made so that clients have safe and uninterrupted power supply. The clients include end users, commercial houses, and industries as well as other electrical contractors in North India including Punjab, Haryana, and Chandigarh etc. It is important to keep high standards in the work they deliver as the part of electrical contracting services. Offering premium quality of work is important so that clients get value for their money.

General features of Main Distribution Board

- Busbars and incoming terminals are fully shrouded
- Box type terminals are provided on outgoing MCCBs for termination of cables, reducing connection costs
- Metering section and cable plinth can be provided

INCOMER	Load break switch 125 to 800A, 3P with external rotary handle MCCB 100 to 800A, 3-pole, 30kA or 50kA.
OUTGOINGS	MCCBs 15 to 400A, 3 pole, 30kA or 50kA
BUS BARS	H.C.H.D. copper, electrolytic ally tinned and colour coded
ENCLOSURE	Electro galvanized sheet steel, polyester powder coated to RAL 7032 textured, or as per requirement suitable for floor and wall mounting
CABLING	Removable undrilled gland pates on top and bottom, non-ferrous type for single core cables, punched to clients requirements Termination for up to 4 cables per phase can be provided

As per the specifications given by the clients, an exclusive range of power distribution board is designed by the best-in-class technicians at Advance Switchgear Co. They are the manufacturers of one of the safest and cost-effective SMDB that complies with the quality standard. There is reliable after sales service provided by the company that saves installation cost, cost of equipment storage and field testing.

Starter and its Importance:

A 3 point starter in simple words is a device that helps in the starting and running of shunt wound dc motor or compound wound dc motor. Now the question is why these types of dc motors require the assistance of the starter in the first case. The only explanation to that is given by the presence of back emf E_b , which plays a critical role in governing the operation of the motor. The back emf, develops as the motor armature starts to rotate in presence of the magnetic field, by generating action and counters the supply voltage. This also essentially means, that the back emf at the starting is zero, and develops gradually as the motor gathers speed.

MODULE - 4

SERVICE CONNECTION, INSPECTION AND TESTING OF INSTALLATION:

Introduction:

We depend on electricity to light our homes, turn on our television sets, and even cook our meals. When the power goes out because of a storm, a short circuit, or another problem in the electrical circuit, understanding what the basic components of an electrical system is a must.

Your homes' electricity starts with the electrical service connection. This is where the electric company connects their wires to your homes' feeder wires that attach to the meter on your home or power pole. This is the device that measures the amount of electricity your home uses and determines the amount of money the electric company charges you on a monthly basis.

From here your meter either feeds a disconnect switch or a main breaker or fuse panel. A typical home has a single phase service consisting of an "A" phase and a "B" phase, a neutral and a ground wire.

Disconnect Switch

A disconnect switch is mounted on the outside of your home close in proximity to the meter on the outside of your home or power pole. The advantage of having a disconnect switch is for safety. In the event of a fire or flash flood, you can shut the power off from the outside of your home verses having to enter a burning home or a flooded basement.

The other instance is having a transfer switch in which you can switch between live power and a generator for backup power.

Main Breaker

A breaker panel consists of a main breaker that is sized according to your homes' load needs. It is used to turn the power on and off to the entire electrical panel. Typically, homes have a 100 amp or a 200 amp service.

A main breaker of 100 amps will only allow 100 amps to flow through it without tripping. In a tripped state, no current will flow throughout the panel. It is the interrupt between the service and the branch circuits of the panel.

This main breaker protects the main service wires from damages that would occur given an overload. In that case, the wires would heat up and eventually could cause a fire.

Branch Circuit Breakers

Breakers that feed lighting, outlets, central air conditioning and sub-panels are considered branch circuits. These circuits can either be 120 volts or 240 volts.

The 120 volt circuits require a single pole breaker, using only one phase of the electrical service. These circuits provide power to lighting, outlets and furnaces. The breakers are usually sized at 15 or 20 amps.

In a 240 volt circuit, a two-pole breaker uses both phases of a circuit. Examples of 240 volt appliances would be an electric range, an electric stove or central air conditioning.

These appliances don't work unless both "A" and "B" phases are working. Most of these examples would require a two-pole 30 amp breaker.

Remember to size your breaker by the name plate rating on the device you are connecting to.

Switches

Switches are the devices that turn on and off lights and fans in your home. These switches come in many different styles and colors to suit your design needs. There are single-pole, three-way,

four-way and dimmer switches. Their purpose is to alter the flow of current to your lights and fans in a home.

Outlets

Electrical outlets are used to plug portable devices into. Televisions, lights, computers, freezers, vacuums and toasters are all good examples of devices that can be plugged into an outlet.

Outlets consist of a hot feed, a neutral and a ground. Some outlets are used especially for wet areas.

Wiring

Your home's wiring consists of romex, BX cable or wiring concealed in conduit. Romex is a brand name for a type of plastic insulated wire. The formal name is NM that means non-metallic sheath. This is suitable for use in dry, protected areas (inside stud walls, on the sides of joists, etc.), that are not subject to mechanical damage or excessive heat.

Bx cable is known as armored cable. Wires are covered by aluminum or steel flexible sheath that is somewhat resistant to damage.

Single strands of conductor wire are pulled through conduit that is the safest method for wiring for durability purposes.

These different types of wiring carry electrical current from the panel to the device being fed. Wiring is sized according to the load demand required. Check the rated required load requirements marked on each device to determine the needed size wire to carry the needed load.

Types of service connection and their features:

This describes various types of utility electrical services and supply voltages. The nominal system supply voltages listed below can vary by $\pm 10\%$ or more. Watt Node meter models are

available in seven different versions that cover the full range of electrical services types and voltages. Meters and current transformers are designed for use on either 50 or 60 Hz systems.

Classification of Different Services:

Alternating current electric power distribution systems can be classified by the following properties:

- Frequency: 50 Hz or 60 Hz
- Number of phases: single or three phase
- Number of wires: 2, 3, or 4 (not counting the safety ground)
- Neutral present:
 - Wye connected systems have a neutral
 - Delta connected systems typically do not have a neutral
 - Voltage levels:
 - Low Voltage: 600 volts or less
 - Medium Voltage: 601 volts to about 34,500 volts
 - High Voltage: 46,000 volts and up

Wye Line-to-Neutral Voltage	Wye or Delta Line-to-Line Voltage
120	208
120	240
230	400
240	415
277	480
347	600

- Line-to-line voltages are typically 1.732 times the phase-to-neutral voltages: $\sqrt{3} = 1.732$
- In symmetrical three-phase electrical system, the phase-to-neutral voltages should be equal if the load is balanced.

V Semester

15EE553: ESTIMATION AND COSTING

Module 5

Estimation of Substations: Main Electrical connection, Graphical Symbols for Various Types of Apparatus and Circuit Elements on Substation main Connection Diagram, Single Line Diagram of Typical Substations, Equipment for Substation, Substation Auxiliaries Supply, Substation Earthing.

8 Hours

TEXT BOOK:

1. **Electrical Installation Estimating & Costing**, J.B.Gupta, VIII Edition S.K. Katria & Sons New Delhi

REFERENCE BOOKS:

1. **Electrical Design Estimating and Costing**, K.B.Raina S.K.Bhattacharya, New Age International
2. **Electrical Wiring Estimating and Costing**, Uppal, Khanna Publishers Delhi
3. **I.E.Rules and Act Manuals**

MODULE – 5

DESIGN AND ESTIMATION OF SUBSTATIONS:

- ❖ Introduction
- ❖ Substation Classification
- ❖ Selection and location of site for substation
- ❖ Substation Earthing
- ❖ Key diagram of typical substations

Introduction

A substation is a part of an electrical generation, transmission, and distribution system. Substations transform voltage from high to low, or the reverse, or perform any of several other important functions. Between the generating station and consumer, electric power may flow through several substations at different voltage levels.

Substations may be owned and operated by an electrical utility, or may be owned by a large industrial or commercial customer. Generally substations are unattended, relying on SCADA for remote supervision and control.

A substation may include transformers to change voltage levels between high transmission voltages and lower distribution voltages, or at the interconnection of two different transmission voltages. The word substation comes from the days before the distribution system became a grid. As central generation stations became larger, smaller generating plants were converted to distribution stations, receiving their energy supply from a larger plant instead of using their own generators. The first substations were connected to only one power station, where the generators were housed, and were subsidiaries of that power station.

Substations

Electric power is produced at the power generating stations, which are generally located far away from the load centers. High voltage transmission lines are used to transmit the electric power from the generating stations to the load centers. Between the power generating station and consumers a number of transformations and switching stations are required. These are generally known as substations. Substations are important part of power system and form a link between generating stations, transmission systems and distribution systems. It is an assembly of electrical components such as bus-bars, switchgear apparatus, power transformers etc.

Their main functions are to receive power transmitted at high voltage from the generating stations and reduce the voltage to a value suitable for distribution. Some substations provide facilities for switching operations of transmission lines, others are converting stations. Substations are provided with safety devices to disconnect equipment or circuit at the time of faults. Substations are the convenient place for installing synchronous condensers for the purpose of improving power factor and it provide facilities for making measurements to monitor the operation of the various parts of the power system.

The substations may be classified in according to service requirements and constructional features. According to service requirements it is classified in to transformer substations, switching substations and converting substations.

The present-day electrical power system is a.c. i.e. electric power is generated, transmitted and distributed in the form of alternating current. The electric power is produced at the power stations which are located at favourable places, generally quite away from the consumers. It is delivered to the consumers through a large network of transmission and distribution. At many places in the line of the power system, it may be desirable and necessary to change some

Characteristic (e.g. voltage, a.c to d.c., frequency, p.f etc.) of electric supply. This is accomplished by suitable apparatus caled sub-station. For example, generation voltage (11 kV or 6.6 kV) at the power station is stepped up to high voltage (say 220 kV or 132 kV) for transmission of electric power. The assembly of apparatus (e.g. transformer etc.) used for this purpose is the sub-station. Similarly, near the consumers localities, the voltage may have to be stepped down to utilization level. This job is again accomplished by a suitable apparatus called sub-station.

Yet at some places in the line of the power system, it may be desirable to convert large quantities of a.c. power to d.c power e.g. for traction, electroplating, d.c motors etc. This job is again performed by suitable apparatus (e.g ignitron) called sub-station. It is clear that type of equipment needed in a sub-station will depend upon the service requirement. Although there can be several types of sub-stations, we shall mainly confine our attention to only those sub-stations where the incoming and outgoing supplies are a.c. i.e. sub-stations which change the voltage level of the electric supply.

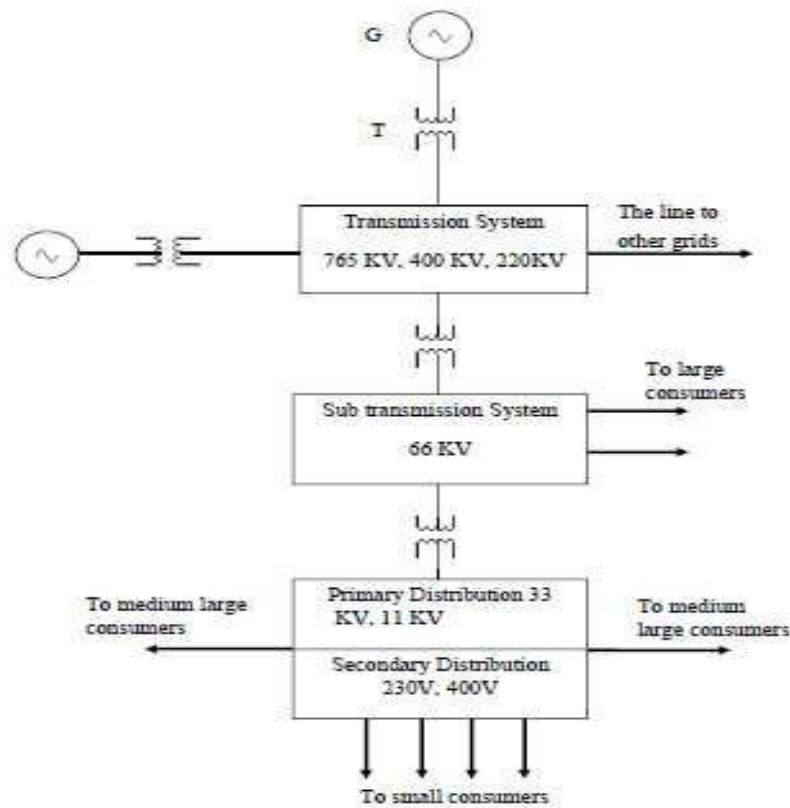
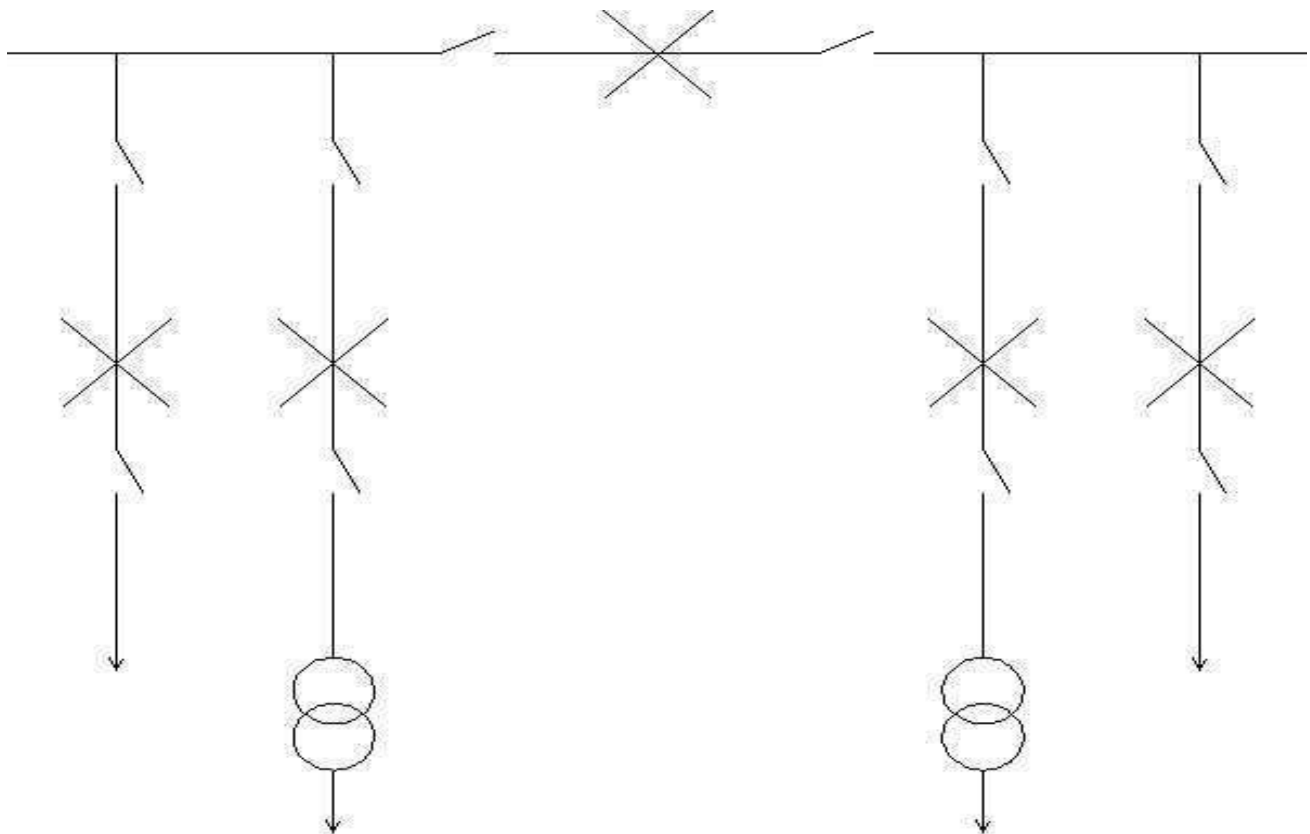

Figure 1.1 Single line Power System Network

Types of Substations:

1. Single Busbar:

The general schematic for such a substation is shown in the figure below.



With this design, there is an ease of operation of the substation. This design also places minimum reliance on signalling for satisfactory operation of protection. Additionally there is the facility to support the economical operation of future feeder bays.

Such a substation has the following characteristics.

Each circuit is protected by its own circuit breaker and hence plant outage does not necessarily result in loss of supply.

A fault on the feeder or transformer circuit breaker causes loss of the transformer and feeder circuit, one of which may be restored after isolating the faulty circuit breaker.

A fault on the bus section circuit breaker causes complete shutdown of the substation. All circuits may be restored after isolating the faulty circuit breaker. A busbar fault causes loss of one transformer and one feeder.

Maintenance of one busbar section or isolator will cause the temporary outage of two circuits.

Maintenance of a feeder or transformer circuit breaker involves loss of the circuit. Introduction of bypass isolators between busbar and circuit isolator allows circuit breaker maintenance facilities without loss of that circuit.

2. Mesh Substation:

The general layout for a full mesh substation is shown in the schematic below.

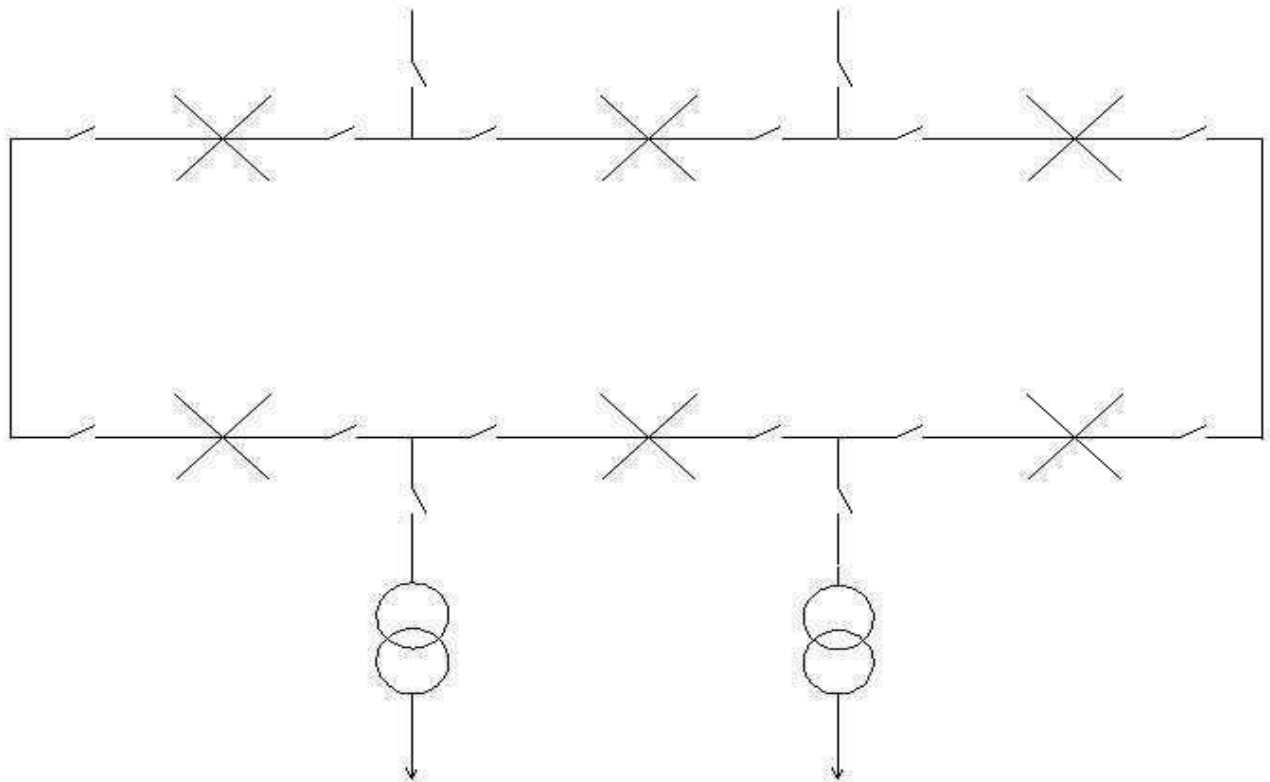

The characteristics of such a substation are as follows.

Operation of two circuit breakers is required to connect or disconnect a circuit, and disconnection involves opening of a mesh. Circuit breakers may be maintained without loss of supply or protection, and no additional bypass facilities are required. Busbar faults will only cause the loss of one circuit breaker. Breaker faults will involve the loss of a maximum of two circuits. Generally, not more than twice as many outgoing circuits as in feeds are used in order to rationalize circuit equipment load capabilities and ratings.

3. One and a half Circuit Breaker layout:

The layout of a 1 1/2 circuit breaker substation is shown in the schematic below.

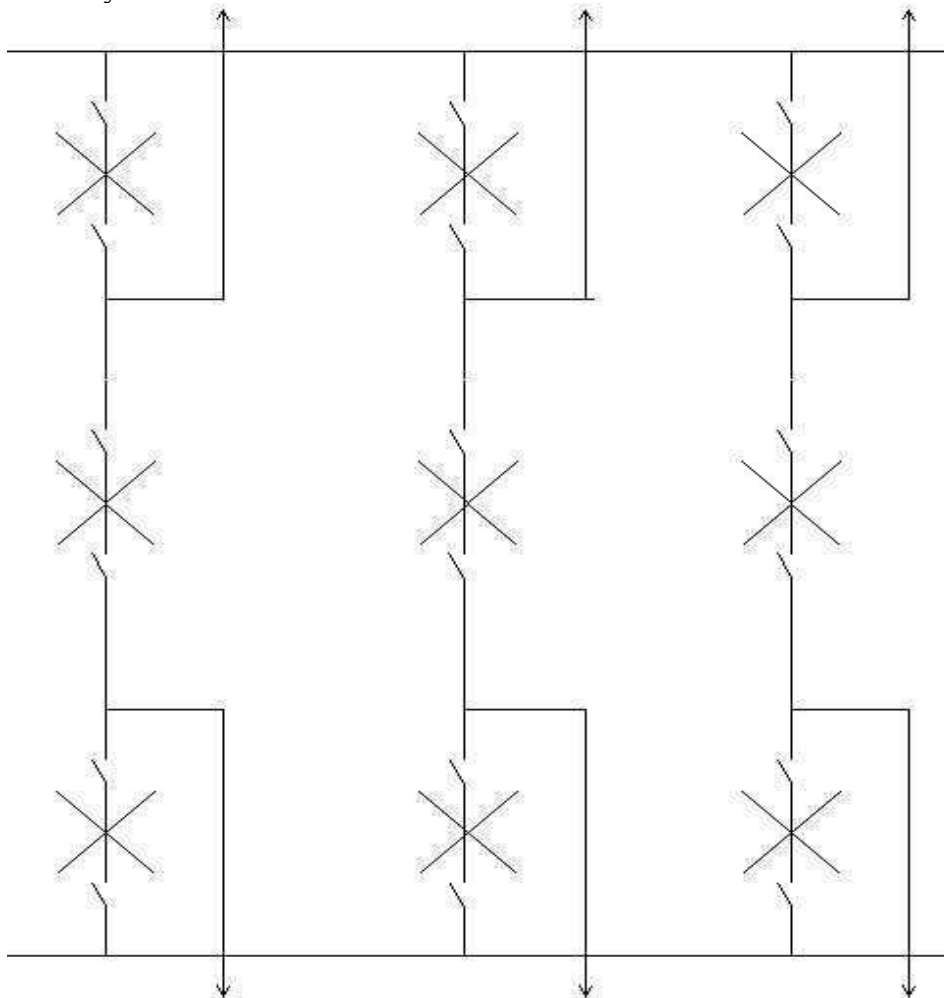

The reason that such a layout is known as a 1 1/2 circuit breaker is due to the fact that in the design, there are 9 circuit breakers that are used to protect the 6 feeders. Thus, 1 1/2 circuit breakers protect 1 feeder. Some characteristics of this design are:

There is the additional cost of the circuit breakers together with the complex arrangement. It is possible to operate any one pair of circuits, or groups of pairs of circuits. There is a very high security against the loss of supply.

4. Main and Auxiliary bus bar:

This is technically a single bus bar arrangement with an additional bus bar called “Auxiliary bus” energized from main bus bars through a bus coupler circuit, i.e., for ‘n’ number of circuits, it employs ‘n + 1’ circuit breakers. Each circuit is connected to the main bus bar through a circuit breaker with isolators on both sides and can be connected to the auxiliary bus bar through an isolator. The additional provision of bus coupler circuit (Auxiliary bus) facilitates taking out one circuit breaker at a time for routine overhaul and maintenance without de – energizing the circuit controlled by that breaker as that circuit then gets energized through bus coupler breaker. As in the case of single bus arrangement, this scheme also suffers from the disadvantages that in the event of a fault on the main bus bar or the associated isolator, the entire substation is lost. This bus arrangement has been extensively used in 132 kV Sub Stations.

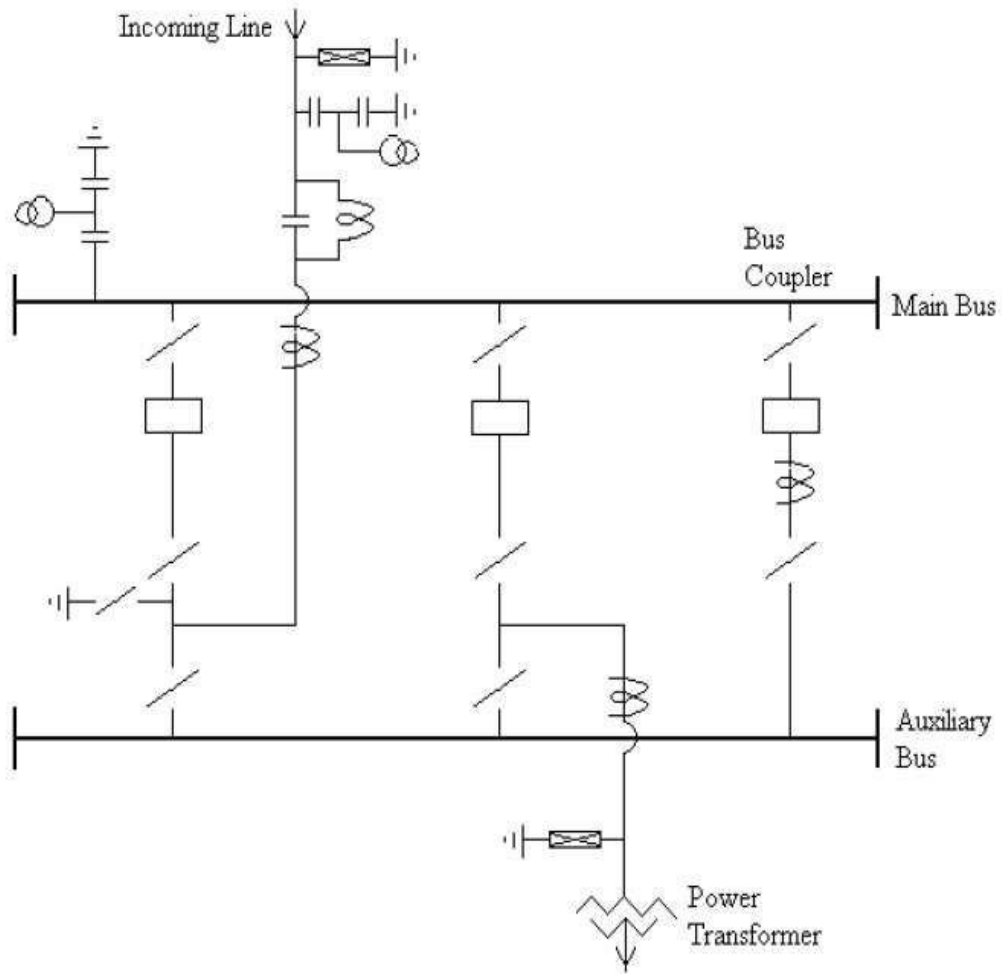

TYPICAL MAIN AND AUXILIARY BUS BAR ARRANGEMENT

5. Double bus bar:

In this scheme, a double bus bar arrangement is provided. Each circuit can be connected to either one of these bus bars through respective bus bar isolator. Bus coupler breaker is also provided so that the circuits can be switched on from one bus to the other on load. This scheme suffers from the disadvantage that when any circuit breaker is taken out for maintenance, the associated feeder has to be shut down. This Bus bar arrangement was generally used in earlier 220 kV sub stations.

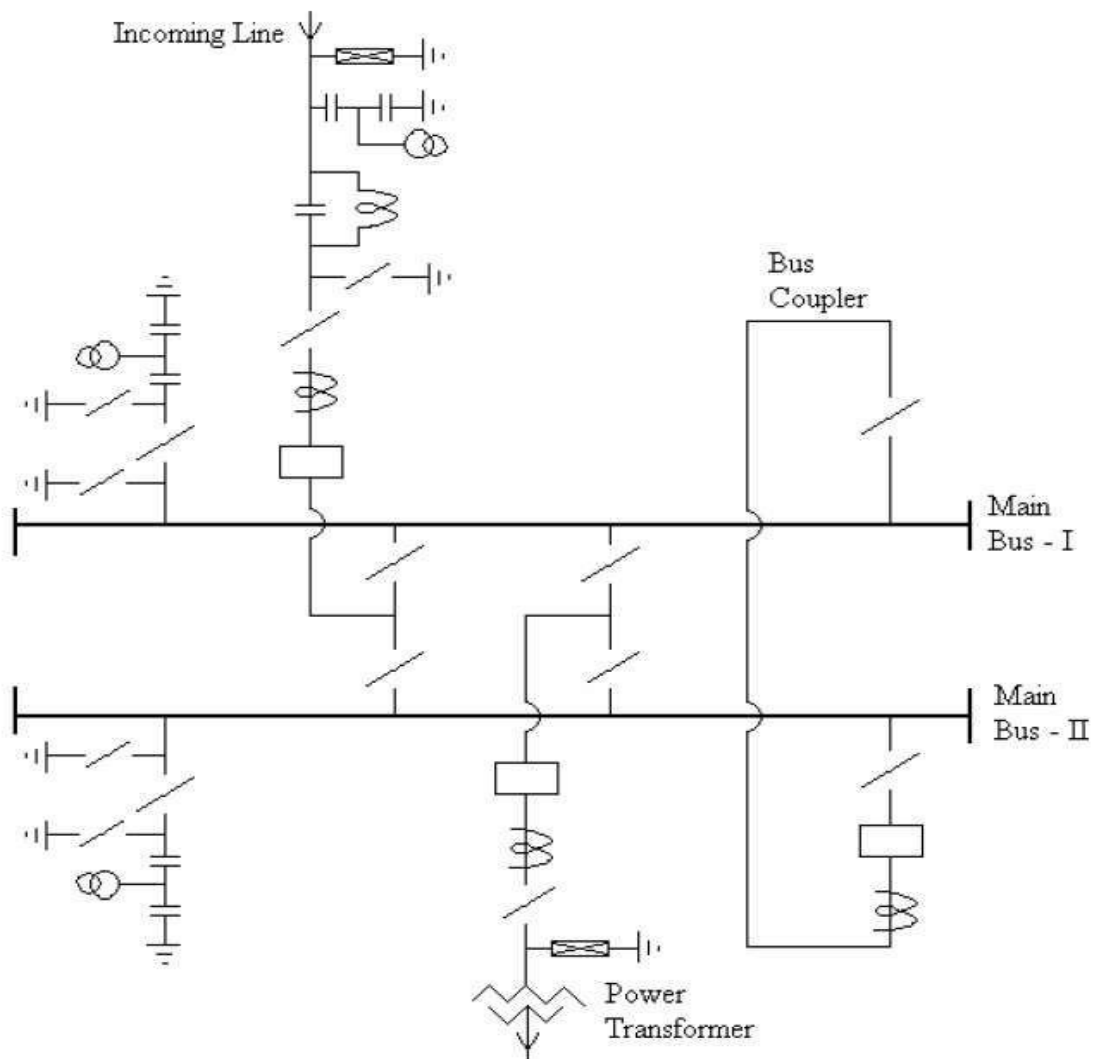

TYPICAL DOUBLE BUS BAR ARRANGEMENT

6. Double Main and Auxiliary bus bar:

The limitation of double bus bar scheme can be overcome by using additional Auxiliary bus, bus coupler breaker and Auxiliary bus isolators. The feeder is transferred to the Auxiliary bus during maintenance of its controlling circuit breaker without affecting the other circuits. This Bus bar arrangement is generally used nowadays in 220 kV sub stations.

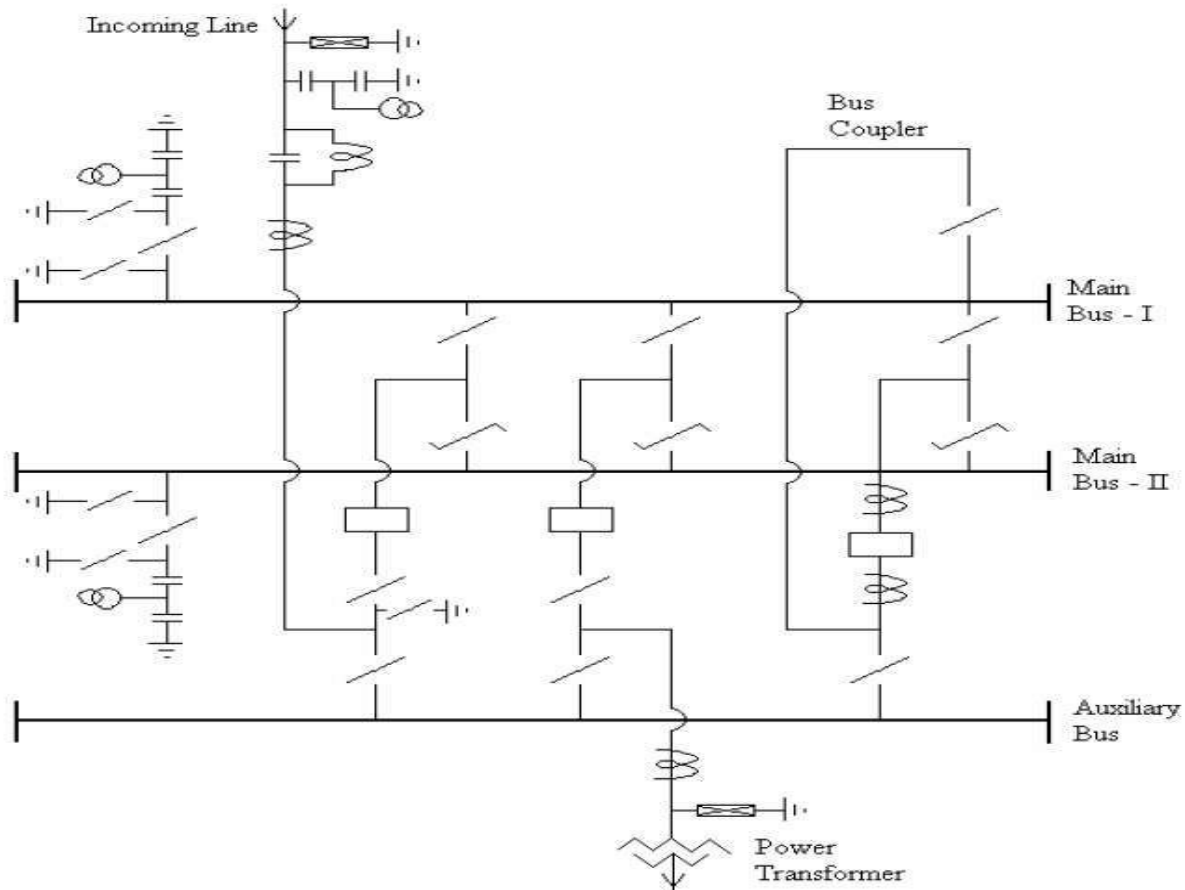

TYPICAL DOUBLE MAIN AND AUXILIARY BUS BAR ARRANGEMENT

Classification of sub-station

There are several ways of classifying sub-station. However the two most important way of classifying them are.

- According to service requirement
- According to constructional features

According to service requirement:

According to service requirement sub-station may be classified into.

1. Transformer sub-station

Those sub-station which change the voltage level of electrical supply are called TIF s/s.

2. Switching sub-station :

These sub-station simply perform the switching operation of power line.

3. Power factor correction S/S :

These sub-station which improve the p.f. of the system are called p.f. correction s/s. these are generally located at receiving end s/s.

4. Frequency changer S/S :

Those sub-stations, which change the supply frequency, are known as frequency changer s/s. Such s/s may be required for industrial utilization

5. Converting sub-station :

Those sub-station which change a.c. power into d.c. power are called converting s/s
ignition is used to convert AC to dc power for traction, electroplating, electrical welding etc.

6. Industrial sub-station:

Those sub-stations, which supply power to individual industrial concerns, are known as industrial sub-station.

According to constructional features :

According to constructional features, the sub-station are classified as :

1) Outdoor Sub-Station :-

For voltage beyond 66KV, equipment is invariably installed outdoor. It is because for such Voltage the clearances between conductor and the space required for switches, C.B. and other equipment becomes so great that it is not economical to installed the equipment indoor.

2)Indoor Sub-station :-

For voltage upto 11KV, the equipment of the s/s is installed indoor because of economic consideration. However, when the atmosphere is contaminated with impurities, these sub-stations can be erected for voltage upto 66KV

3) Underground sub-station :-

In thickly populated areas, the space available for equipment and building is limited and the cost of the land is high. Under such situations, the sub-station is created underground. The design of underground s/s requires more careful consideration.

- The size of the s/s should be as minimum as possible.
- There should be reasonable access for both equipment & personal.
- There should be provision for emergency lighting and protection against fire.
- There should be good ventilation

4) Pole-mounted sub-station:-

This is an outdoor sub-station with equipment installed overhead on H.pole or 4-pole structure. It is the cheapest form of s/s for voltage not exceeding 11KV (or 33KV in some cases). Electric power is almost distributed in localities through such sub-station. The 11KV line is connected to the T/F (11KV/440V) through gang isolator and fuses. The lightning arresters are installed on the H.T. Side to protect the sub-station from lightning strokes. The T/F step down

voltage to 400 V, 3 phase, 4 wire supply. The voltage between any two lines is 400 V & between line & neutral is 230V. The oil ckt breaker installed on the L.T. side automatically isolates the mounted sub-station. T/F are generally in the event of fault generally 200KVA T/F is used.

SUBSTATION PARTS AND EQUIPMENTS

Each sub-station has the following parts and equipment.

1. Outdoor Switchyard

- Incoming Lines
- Outgoing Lines
- Bus bar
- Transformers
- Bus post insulator & string insulators
- Substation Equipment such as Circuit-breakers, Isolators, Earthing Switches, Surge Arresters, CTs, VTs, Neutral Grounding equipment.
- Station Earthing system comprising ground mat, risers, auxiliary mat, earthing strips, earthing spikes & earth electrodes.
- Overhead earth wire shielding against lightening strokes.
- Galvanised steel structures for towers, gantries, equipment supports.
- PLCC equipment including line trap, tuning Module, coupling capacitor, etc.
- Power cables
- Control cables for protection and control
- Roads, Railway track, cable trenches
- Station illumination system

2. Main Office Building

- Administrative building
- Conference room etc.

3. 6/10/11/20/35 KV Switchgear, LV

- Indoor Switchgear

4. Switchgear and Control Panel Building

- Low voltage a.c. Switchgear

- Control Panels, Protection Panels

5. Battery Room and D.C. Distribution System

- D.C. Battery system and charging equipment
- D.C. distribution system

6. Mechanical, Electrical and Other Auxiliaries

- Fire fighting system
- D.G. Set
- Oil purification system

An important function performed by a substation is switching, which is the connecting and disconnecting of transmission lines or other components to and from the system. Switching events may be “planned” or “unplanned”. A transmission line or other component may need to be de energized for maintenance or for new construction; for example, adding or removing a transmission line or a transformer. To maintain reliability of supply, no company ever brings down its whole system for maintenance. All work to be performed, from routine testing to adding entirely new substations, must be done while keeping the whole system running.

Perhaps more importantly, a fault may develop in a transmission line or any other component. Some examples of this: a line is hit by lightning and develops an arc, or a tower is blown down by a high wind. The function of the substation is to isolate the faulted portion of the system in the shortest possible time.

There are two main reasons: a fault tends to cause equipment damage; and it tends to destabilize the whole system. For example, a transmission line left in a faulted condition will eventually burn down, and similarly, a transformer left in a faulted condition will eventually blow up. While these are happening, the power drain makes the system more unstable. Disconnecting the faulted component, quickly, tends to minimize both of these problems.

Selection and location of site for substation:

Voltage levels, voltage regulation, the cost of sub transmission, substation, primary feeder mains and distribution transformers dictate the location of a substation. However, the following rules are to be considered for the selection of an ideal location for a substation:

- The substation should be located nearer the load centre of its service areas, so that its distance from the substation is minimum.
- Proper voltage regulation should be possible without taking extensive measures.

- There should be proper access for incoming sub-transmission lines and outgoing primary feeders.
- It should provide enough space for future expansion.
- It should help minimize the number of customers affected by any service interruption.

The following factors are considered while making site selection for a substation

1. **Type of substation:** The category substation is important for its location. For example a step-up substation, which is generally a point where power from various sources (generating machines or generating stations) is pooled and stepped up for long distance transmission, should be located as close to the generating stations as possible to minimize the transmission losses. Similarly a step-down substation should be located nearer to the load centre to reduce transmission losses, cost of distribution system and better reliability of supply.

2. **Availability of suitable and sufficient land:** The land proposed for a substation should be normally level and open from all sides. It should not be water logged particularly in rainy season. According to the latest practice the land required for various types of Substations is given below:

Type of Substation	Area Required
i. 400 kV substation	50 acres
ii. 220 kV substation	25 acres
iii. 132 kV substation	10 acres





3. **Communication facility:** Suitable communication facility is desirable at a proposed substation both during and after its construction. It is better, therefore, to select the site alongside on existing road to facilitate an easier and cheaper transportation.

4. **Atmospheric pollution:** atmosphere around factories, which, may produce metal corroding gases, air fumes, conductive dust etc., and nearer sea coasts, where air may be more humid and may be salt laden, is detrimental to the proper running of power system and therefore substations should not be located near factories or sea coast.

5. **Availibility of essential amenities to the staff:** The site should be such where staff can be provided essential amenities like school, hospital, drinking water, housing etc.

6. **Drainage facility:** The site selected for the proposed substation should have proper drainage arrangement or possibility of making effective drainage arrangement to avoid pollution of air and growth of micro-organisms detrimental to equipment and health.

Key diagram of typical substations:

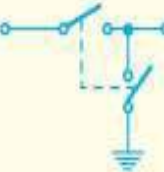
S.No.	Circuit element	Symbol
1	Bus-bar	
2	Single-break isolating switch	
3	Double-break isolating switch	
4	On load isolating switch	
5	Isolating switch with earth Blade	

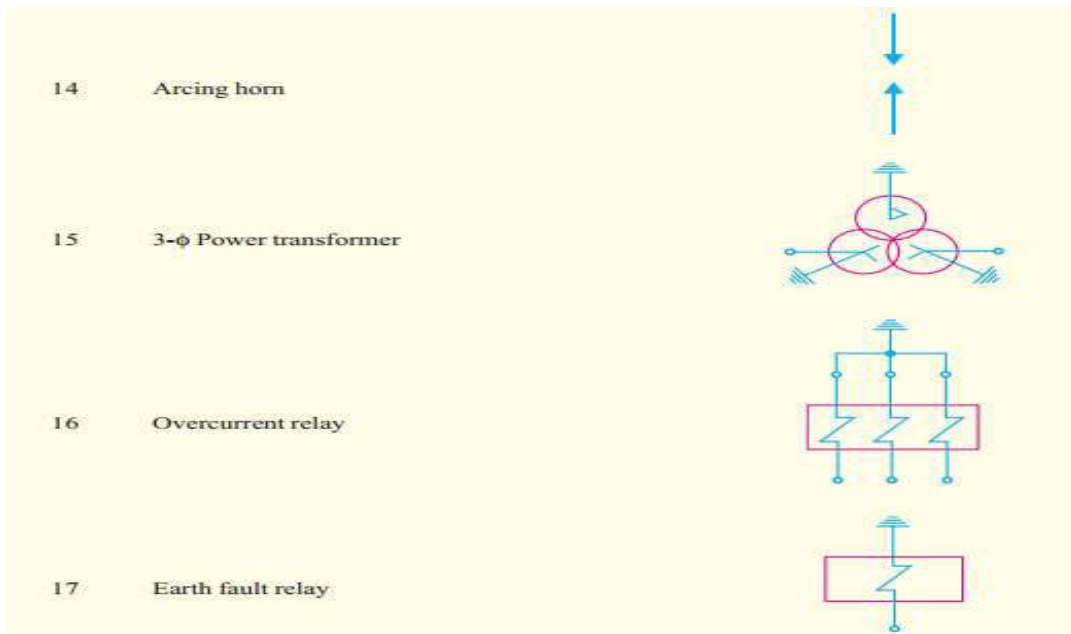
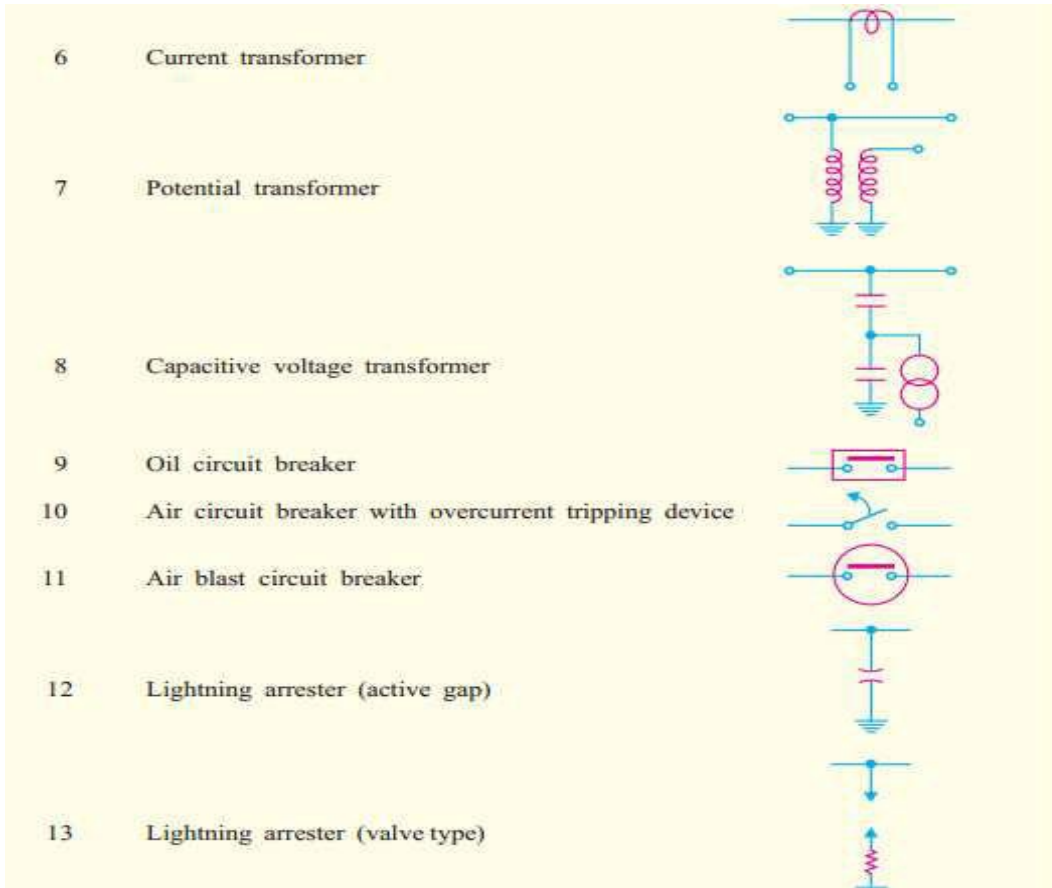

Key diagram of typical substations:

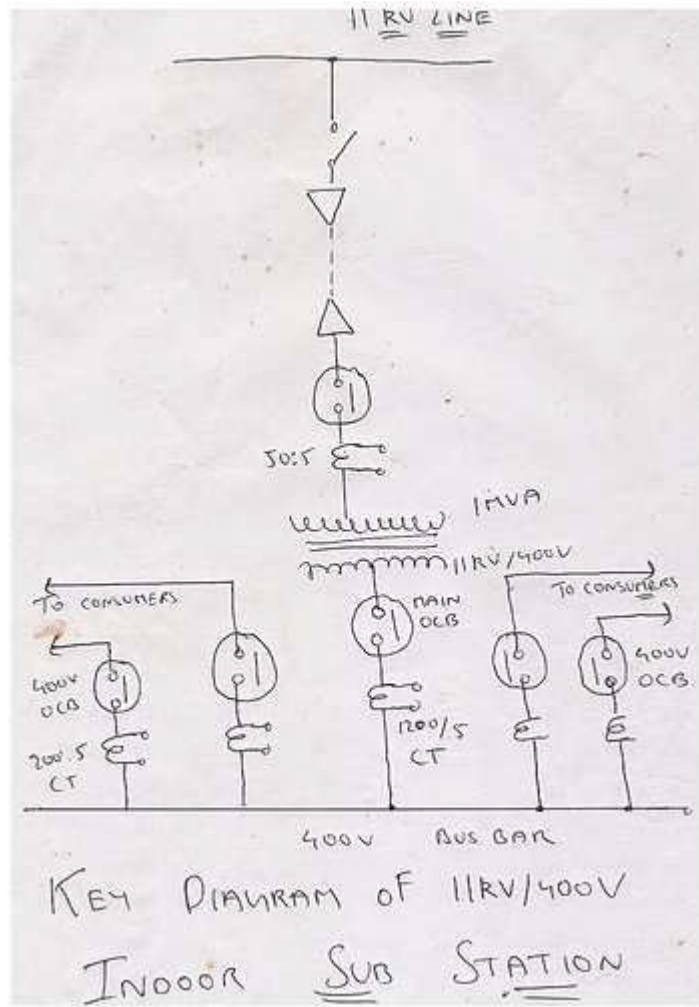

(i) The 3-phase, 3-wire 11 kV line is tapped and brought to the gang operating switch installed near the sub-station. The G.O. switch consists of isolators connected in each phase of the 3-phase line.

(ii) From the G.O. switch, the 11 kV line is brought to the indoor sub-station as underground cable. It is fed to the H.T. side of the transformer (11 kV/400 V) via the 11 kV O.C.B. The transformer steps down the voltage to 400 V, 3-phase, 4-wire.

(iii) The secondary of transformer supplies to the bus-bars via the main O.C.B. From the busbars, 400 V, 3-phase, 4-wire supply is given to the various consumers via 400 V O.C.B. The voltage

between any two phases is 400 V and between any phase and neutral it is 230 V. The single phase residential load is connected between any one phase and neutral whereas 3- phase, 400 V motor load is connected across 3-phase lines directly.

(iv) The CTs are located at suitable places in the sub-station circuit and supply for the metering and indicating instruments and relay circuits

Equipment for substation and switchgear installations:

In an electric power system, **switchgear** is the combination of electrical disconnect switches, fuses or circuit breakers used to control, protect and isolate electrical equipment. Switchgear is used both to de-energize equipment to allow work to be done and to clear faults downstream. This type of equipment is directly linked to the reliability of the electricity supply.

The very earliest central power stations used simple open knife switches, mounted on insulating panels of marble or asbestos. Power levels and voltages rapidly escalated, making opening manually operated switches too dangerous for anything other than isolation of a de-energized circuit. Oil-filled equipment allowed arc energy to be contained and safely controlled. By the early 20th century, a switchgear line-up would be a metal-enclosed structure with electrically operated switching elements, using oil circuit breakers. Today, oil-filled equipment has largely been replaced by air-blast, vacuum, or SF6 equipment, allowing large currents and power levels to be safely controlled by automatic equipment incorporating digital controls, protection, metering and communications.

High voltage switchgear was invented at the end of the 19th century for operating motors and other electric machines. The technology has been improved over time and can be used with voltages up to 1,100 kV.

Typically, the switchgear in substations is located on both the high voltage and the low voltage side of large power transformers. The switchgear on the low voltage side of the transformers may be located in a building, with medium-voltage circuit breakers for distribution circuits, along with metering, control, and protection equipment. For industrial applications, a transformer and switchgear line-up may be combined in one housing, called a Moduleized substation or USS.

Substation auxiliaries supply:

All but the smallest substations include auxiliary power supplies. AC power is required for substation building small power, lighting, heating and ventilation, some communications equipment, switchgear operating mechanisms, anti-condensation heaters and motors. DC power is used to feed essential services such as circuit breaker trip coils and associated relays, supervisory control and data acquisition (SCADA) and communications equipment. This chapter describes how these auxiliary supplies are derived and explains how to specify such equipment.

Substation Earthing:

Earthing systems are provided in a substation for the following main reasons:

- To provide a discharge path for lightning arrests, gaps, etc.
- To provide proper grounding for substation equipments.
- To keep the non-current carrying metal parts, such as transformer tank, structures, etc., safe at earth potential even though the insulation fails.

The fault current through the neutral of the transformer to earth is to be distributed over a large area; otherwise the potential gradient of the earth around the earth connection may be dangerous. Earth mat consisting of heavy gauge-bonded conductors or cast iron grid buried at a depth of not less than 30 cm and connected to the earth electrode, serves best to distribute the heavy fault current over a large earth area. For small stations, more number of earthing stations are provided at different places and are interconnected which helps to reduce the potential gradient.

BASIC TERMS OF EARTHING

Earth: An object is said to be earthed when it is electrically connected to an earth electrode. A conductor is said to be solidly earthed when it is electrically connected to an earth electrode without intentional addition of resistance or impedance in the earth connection.

Earth Electrode: A metal plate, pipe, any other conductor or an array of conductors electrically connected to the general mass of the earth.

Earthing Lead: The conductor by which the earth electrode is connected to neutral is called earthing lead.

GROUNDING OR NEUTRAL EARTHING:

The word “earthing” and “grounding” have the same meaning. But equipment earthing is different from neutral-point earthing. Equipment earthing refers to connecting the non-current carrying metallic parts to earth available in the neighbourhood of electrical circuits. For example: motor body, switch gear, Transformer tank, etc.

Thus, the purpose of neutral earthing and that of equipment earthing are distinctly different. Equipment earthing ensures safety while neutral earthing is done mostly to ensure that the stator short-circuit current is limited and for stability reasons.

The very purpose of earthing is to safeguard the equipment against possible damage due to electric shock, fire, etc. It is very important to have good and effective earthing or grounding. Today, the neutral grounding is an important aspect of power-system designs because the performance of the system, in terms of short circuits, stability, protection, etc., is greatly affected by the state of the neutral. In most of the modern high-voltage systems, the neutral of the system is solidly grounded, i.e., the neutral is connected directly to the ground.

METHODS OF NEUTRAL GROUNDING

The various methods of grounding the neutral of the system are:

1. Solid grounding
2. Resistance grounding
3. Reactance grounding
4. Peterson-coil grounding (or resonant grounding)
5. Voltage transformer grounding
6. Earthed transformer

SOLID GROUNDING OR EFFECTIVE GROUNDING:

The term effective grounding is the same as solid grounding. The neutral is directly connected to ground without any impedance between neutral and ground as shown in Fig.1 below

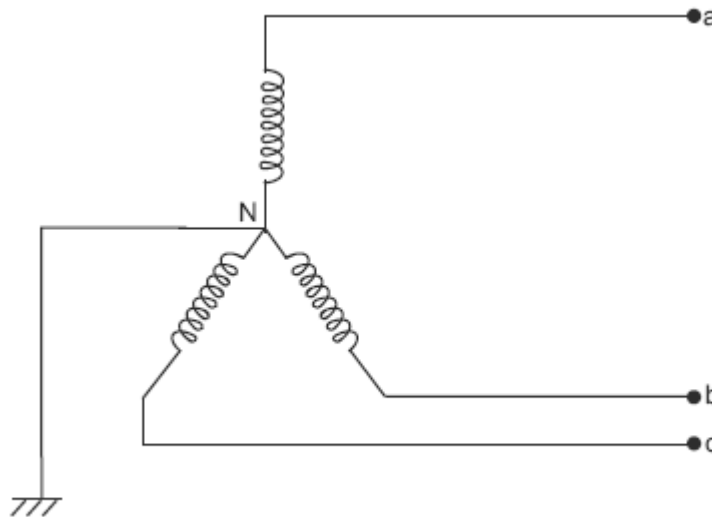

Fig. 13.13 Solidly grounded system

Consider a line to ground fault on any one phase, say phase 'a' at a point F as shown in fig 2. As a result of this fault, the line to neutral voltage of phase 'a' becomes zero, but the phase to the earth voltage of the remaining two healthy phases will be approximately constant.

GROUNDING GRID:

Grounding grids are used where there is a chance of flow of large fault currents through the system. A grounding grid is composed of a number of rods that are joined together through copper conductors to reduce the overall grounding resistance. They are also known as earthing mats or earthing grids. This arrangement should be made near the ground surface as it limits the potential gradient. Driving rods deep into the soil, however, becomes an expensive process, especially in the case of hard soil or soils having low conductivity. The performance of a grounding grid system suffers when the rods are removed from the mesh.

The following factors have to be taken into account while designing a grounding grid:

- ❖ Voltage between the ground surface and the conductor should be kept at a minimum in case of a fault.