



**Bolted Connections:** Introduction, Types of Bolts, Behaviour of bolted joints, Design of High Strength friction Grip (HSFG) bolts, Design of Simple bolted Connections (Lap and Butt joints)

**Welded Connections:** Introduction, Types and properties of welds, Effective areas of welds, Weld Defects, Simple welded joints for truss member, Advantages and Disadvantages of Bolted and Welded Connections.

10 Hours

L1,L2,L3

### Introduction:

Various components of any structure need to be connected by means of fasteners so as to enable them to behave as single composite units. Connections are also required for extending the lengths of members, for connecting columns to footings and for joining two parts of a structure during erection.

Based on tests results, past performance and the ductile behaviour of steel, many approximations and assumptions are made in the design of bolted and welded connection. Following are the requirements of a good connection in steelwork:

- 1) It should be rigid, to avoid fluctuating stresses which may cause fatigue failure.
- 2) It should be such that there is the least possible weakening of the parts to be joined.
- 3) It should be such that it can be easily installed, inspected and maintained.

In general following types of connections are adopted:

- |                         |                        |
|-------------------------|------------------------|
| (a) Riveted connections | (b) Welded Connections |
| (c) Bolted Connections  | (d) Pin Connections    |

### Simple connections:

In many cases, a connection is required to transmit a force only and there may not be any moment acting on the group of connectors, even though the connection may be capable of transmitting some amount of moment. Such a connection is referred to as simple, force, pinned or flexible connection

The different types of simple connections found in steel structures may be classified as follows:

- Lap and Butt joints
- Truss joint connections
- Connections at beam column junctions
- Seat angle connection
- Web angle connection
- Stiffened seat angle connection
- Tension and flange splices.



**Lap and butt joints:**

Lap joint is the one in the plates are connected with overlap with each other. The lap joint may have single – row, staggered or chain bolting connections. Though lap joints are the simplest, they result in eccentricity of the applied loads.

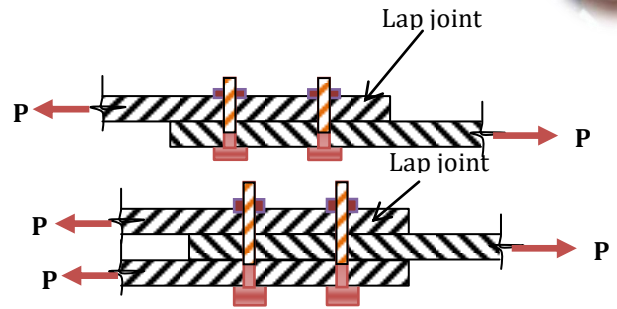

Butt joints connection is the one in the plates are connected butt against each other and connection is made by providing a cover plate on one or both sides of the joint. The Butt joint may have single – row, staggered or chain bolting connections. Butt joints on the other hand eliminate eccentricity at the connection.

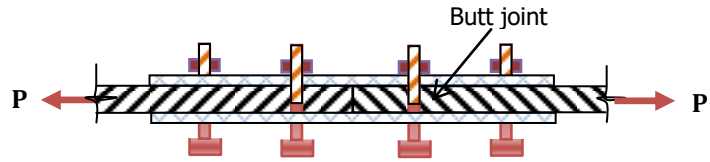

**Truss joint connections:**

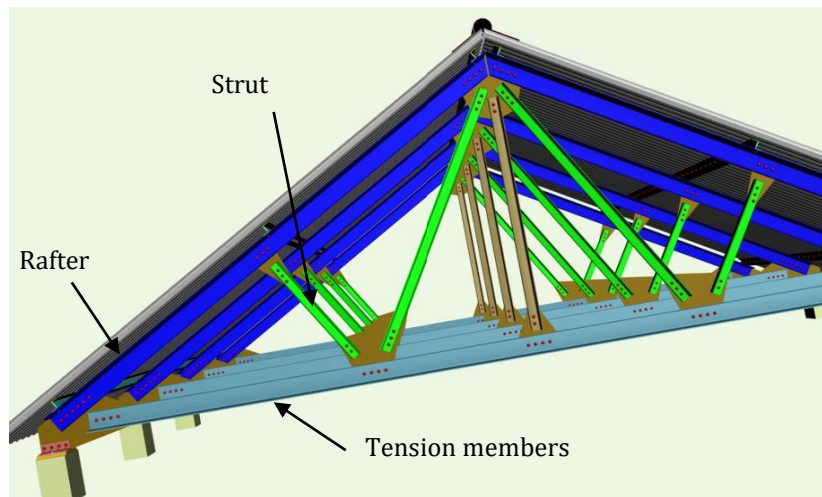

**Beam to beam connection: (Web angle connection)**

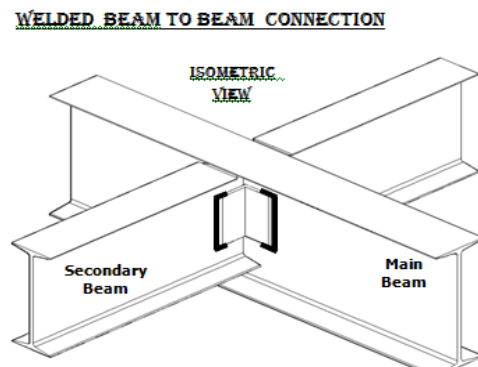
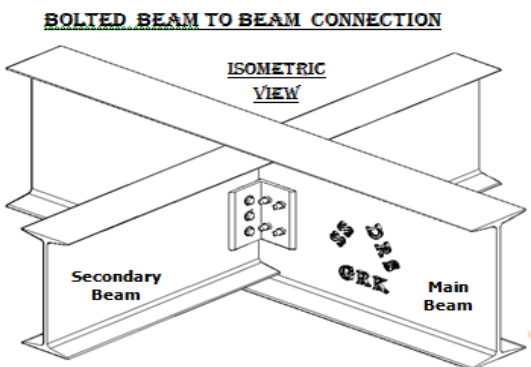



**Connections at beam column junctions**

**BOLTED BEAM TO COLUMN FRAMED CONNECTION**

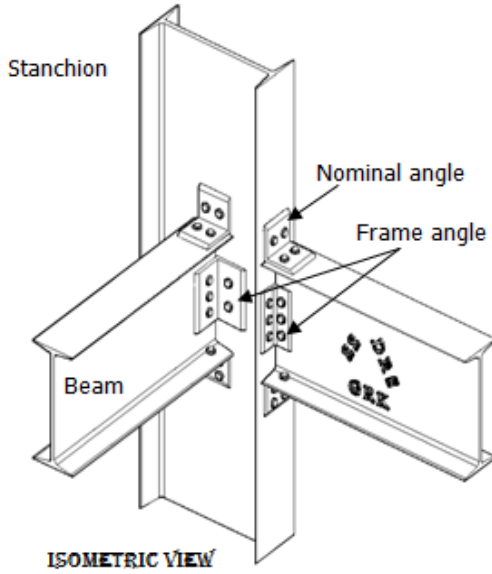

**WELDED BEAM TO COLUMN FRAMED CONNECTION**

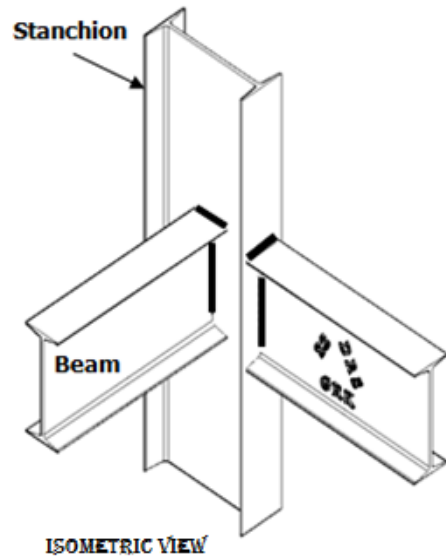

**Seat angle connection:**

**i) Unstiffened seated connection: (Bolted and welded type)**

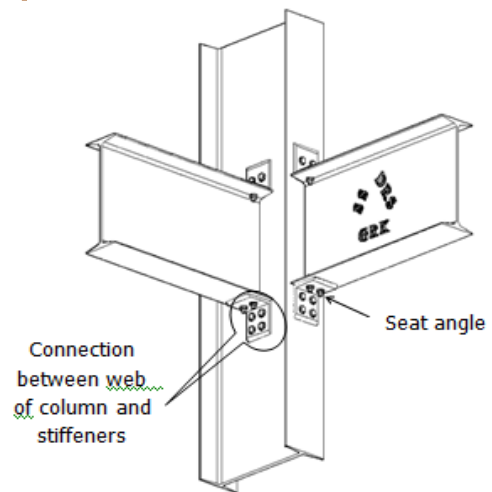
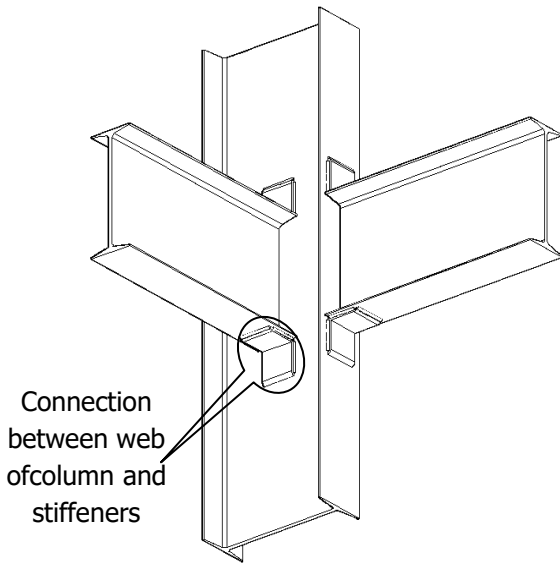



ii) **Stiffened seated connection: (Bolted and welded type)**

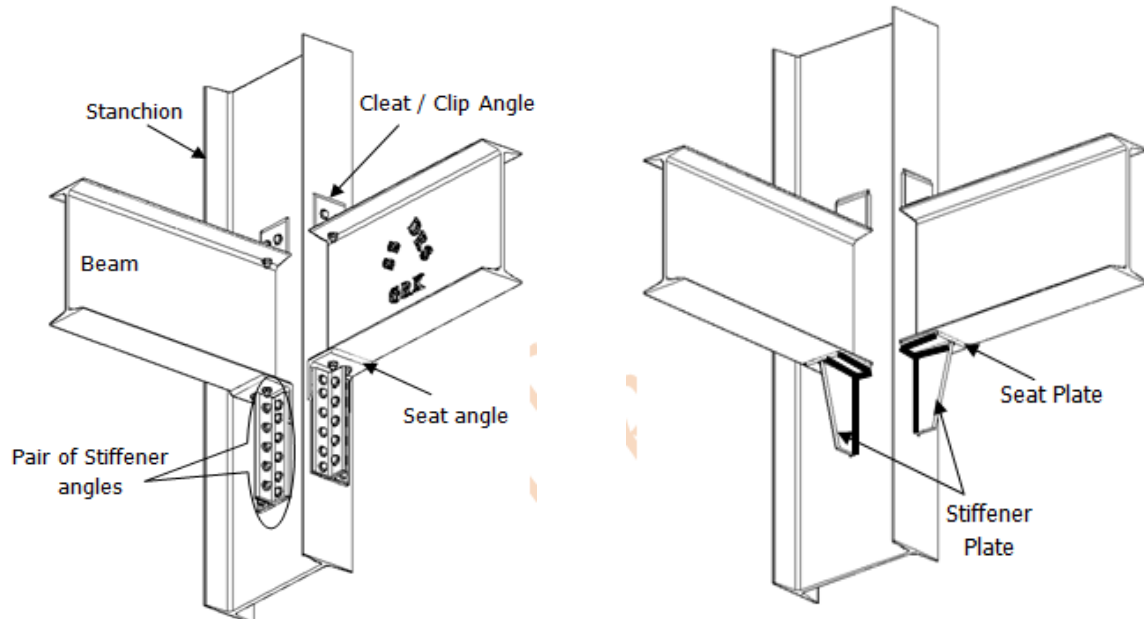

**Bolted joint Connections:**

Bolts may be used for structure not subjected to vibrations. The cost of bolts is more but it takes less time to fabricate structure with bolted connections. The fabrication work with bolts is noise less and less skilled workers can also handle it.

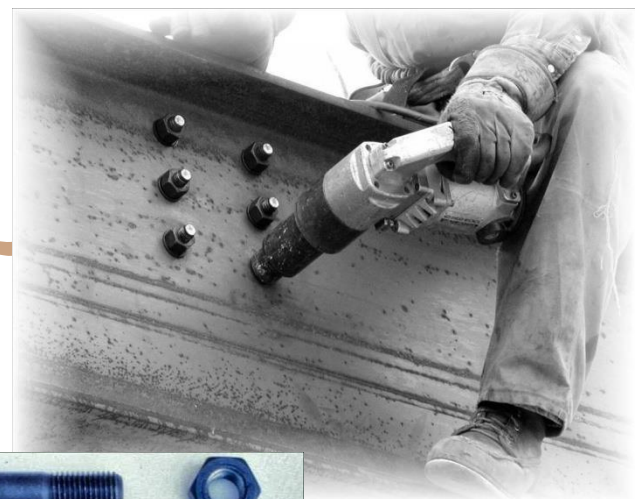

**Parts of the bolts assembly:**

- Grip is the distance from behind the bolt head to the back of a nut or washer
- It is the sum of the thickness of all the parts being joined exclusive of washers.
- Thread length is the threaded portion of the bolt.
- Bolt length is the distance from

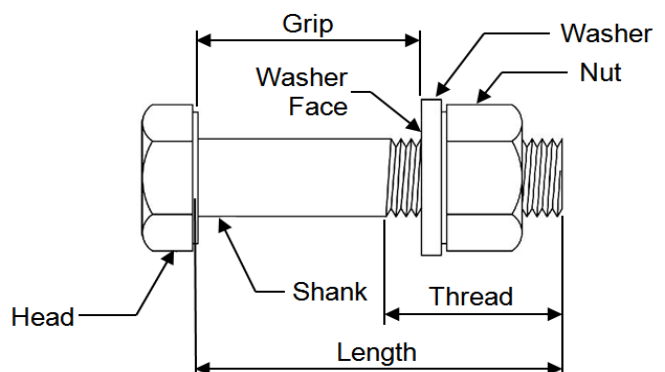



behind the bolt head to the end of the bolt.

**Gauge distance ( $g$ ):** The gauge distance is the transverse distance between two consecutive bolts of adjacent chains and is measured at right angles to the direction of the force in the structural member.

**Pitch of bolts ( $p$ ):** It is the distance between centres of two adjacent bolts in a row measured parallel to the direction of the force.

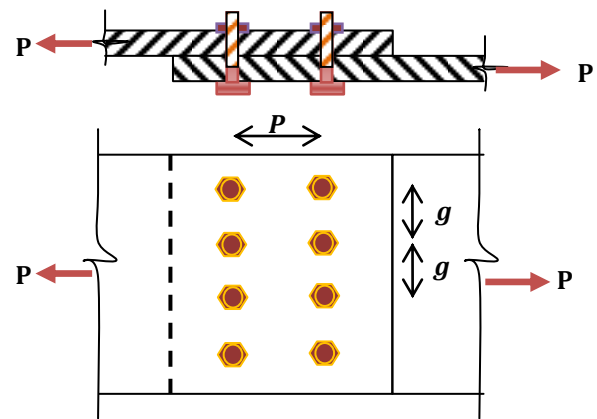

(Note: There is a lot of confusion in the available literature about the nomenclatures 'Pitch' and 'Gauge')

**Diagonal Pitch:** The distance between centres of any two adjacent bolts in the diagonal direction is called diagonal pitch.

**Staggered pitch:** The distance between centres of any two consecutive bolts in a zig – zag bolting, measured parallel to the direction of stress in the member is called staggered pitch

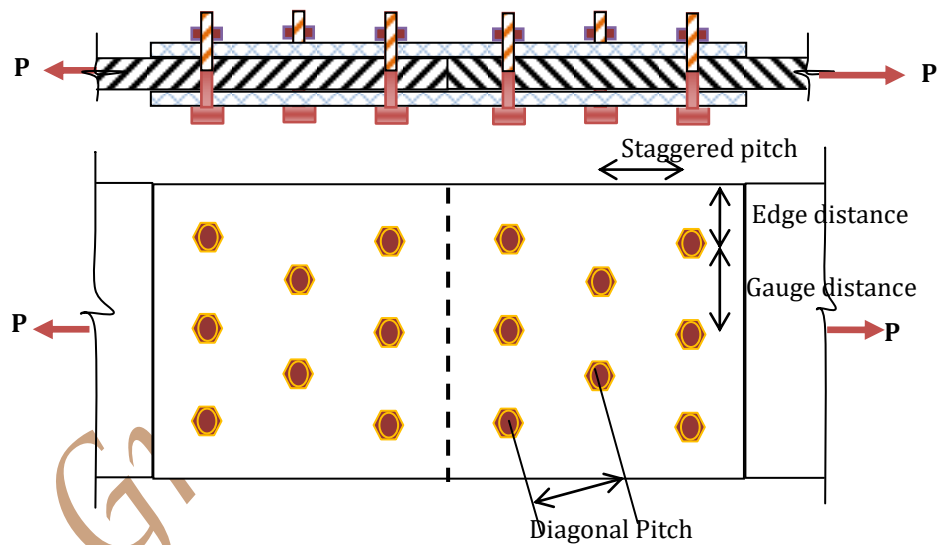

**TYPES OF BOLTED JOINTS:**

There are two types of bolted joints

(i) **Lap joint:** when two members which are to be connected are simply overlapped and connected together by means of bolts or welds, the joint is called a lap joint. The lap joint may have single-row, staggered or chain bolting as shown in Fig.

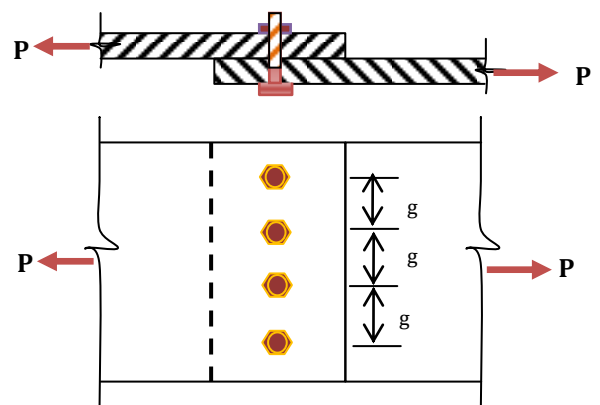



**Double bolted Lap joint**

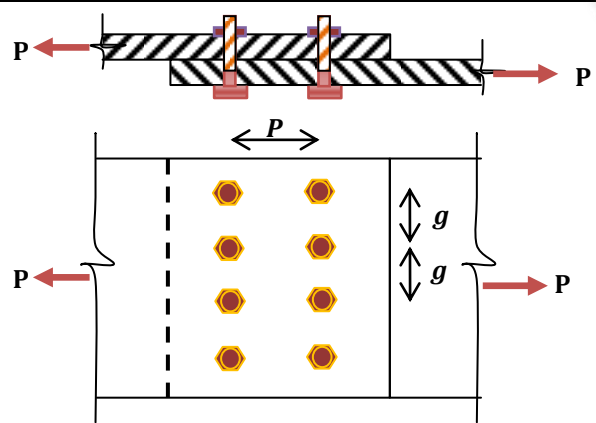

**(ii) Butt joint:** In butt joint the plates are connected against each other and the connection is made by providing a cover plate on one or both sides of the joint.

**(a) Single cover single bolted butt joint:**

In single cover butt joint, bending stresses may develop, tending to distort the joint. This possibility is completely eliminated by using a double cover butt joint.

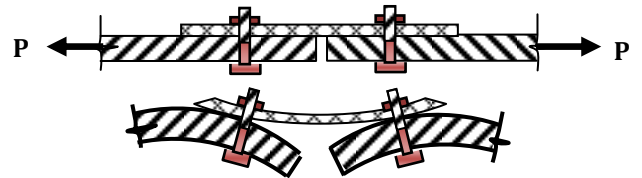

**(b) Double cover single bolted butt joint:**

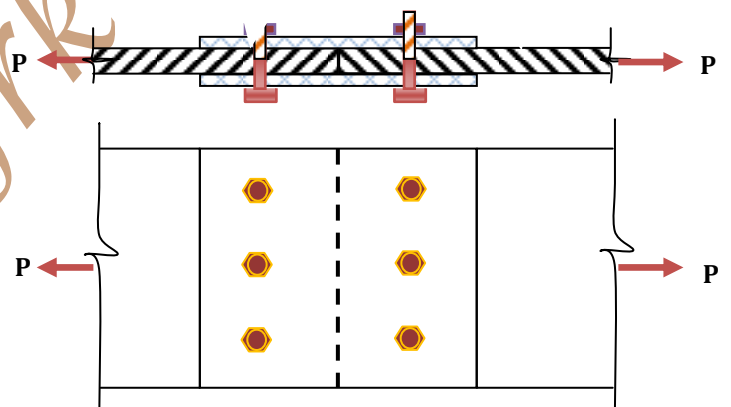

**(c) Double cover chain bolted butt joint:**

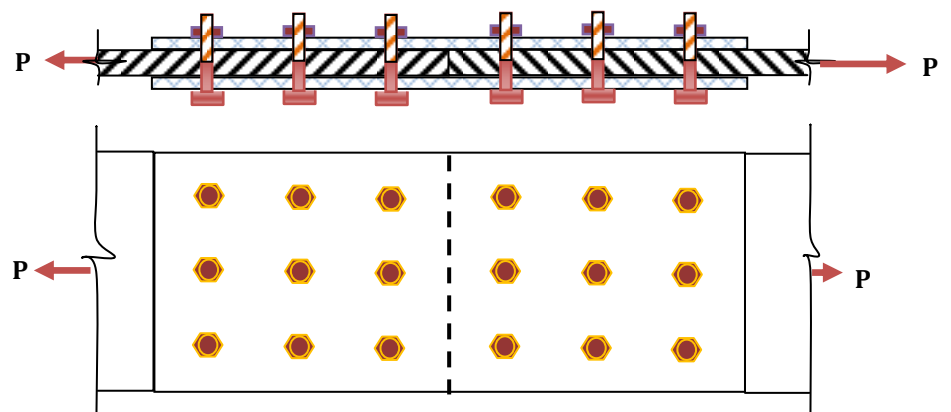





**d) Double cover zig – zag bolted butt joint:**

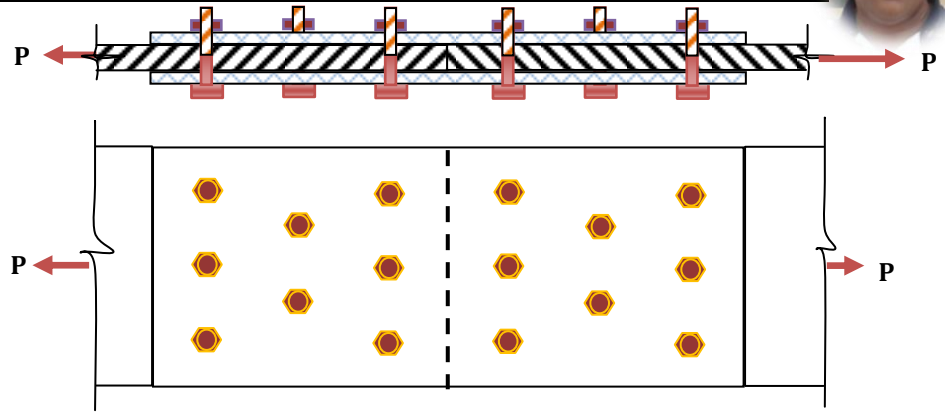

**FAILURE OF A BOLTED JOINT**

Loads are transferred from one member to another by means of the connections between them. The possible "Limit states" or failure modes that may control the strength of a bolted connection are in any of the following ways:

- 1. Shear failure of bolts:** The plates bolted together and subjected to tensile loads may result in the shear of the bolts. The bolts are sheared across their cross-sectional areas. Single shear occurring in a lap joint has been shown in Fig. (a) and double shear occurring in butt joint has been shown in Fig. (b)

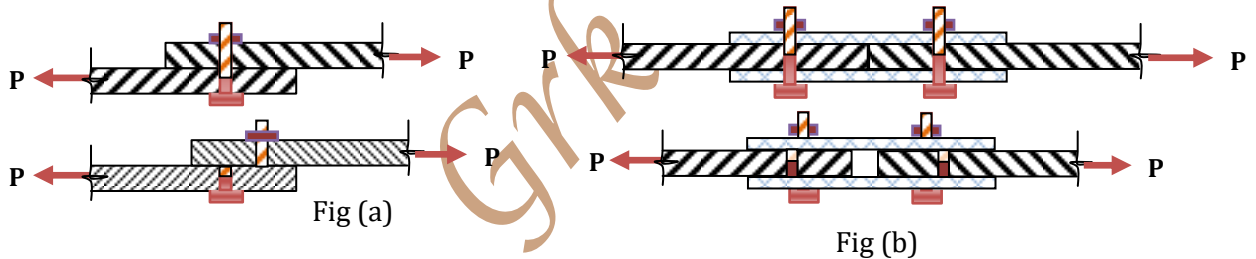

- 2. Shear failure of plates:** A plate may fail in shear along two lines as shown in Fig. This may occur when minimum proper edge distance is not provided.

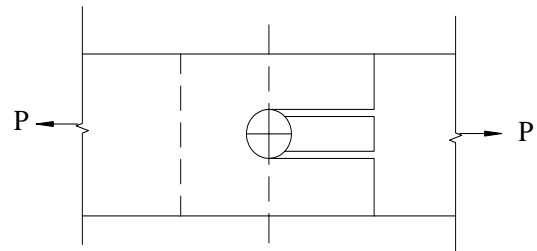

- 3. Tearing failure of plates:** When plates bolted together are carrying tensile load, tearing of plate may occur, when strength of the plate is less than that of bolts. The tearing failure occurs at the net sectional area of plate as shown in Fig.

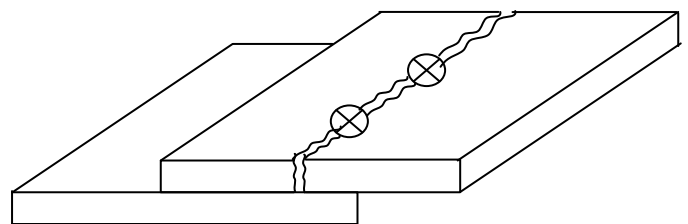
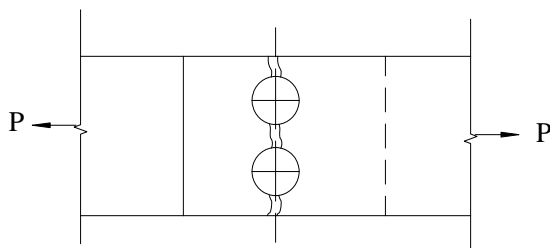



**4. Bearing failure of plates:** The bearing failure of a plate may occur because of insufficient edge distance in the bolted joint. The crushing of plate against the bearing of bolt as shown in Fig takes a place in such failure.

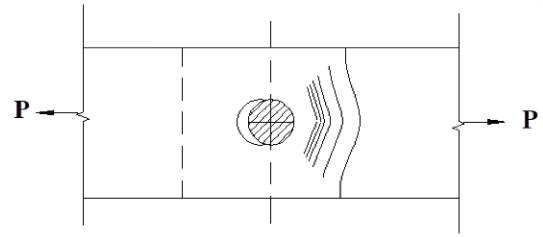

**5. Splitting failure of plates:** The splitting failure of a plate may occur because of insufficient edge distance in the bolted joint. The splitting (cracking) of plate as shown in Fig takes place in such failure.

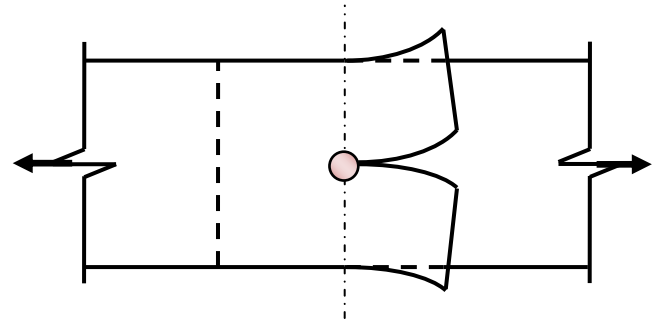

**6. Bearing failure of bolts:** The bearing failure of a bolt occurs when the bolt is crushed by the plate as show in Fig.

The bearing, shearing and splitting failure of plates may be avoided by providing adequate edge distance. To safeguard a bolted joint against other modes of failure, the joint should be designed properly.

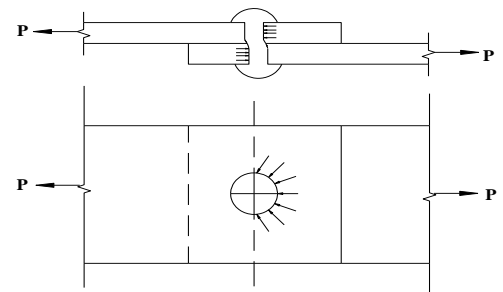

**Strength of bolted joint:**

**P-75, 10.3.3**

**1. Strength of bolted joint against shearing of the bolts ( $V_{dsb}$ ):**

The strength of bolted joint against the shearing of bolts is equal to the product of strength of one bolt inshear and the number of bolts on each side of the joint.

Strength of one bolt in red shear  $V_{dsb} = \frac{V_{nsb}}{\gamma_{mb}}$

$$V_{nsb} = \left( \frac{f_u}{\sqrt{3}} \right) \times (n_n A_{nb} + n_s A_{sb})$$

$$V_{dsb} = \frac{\left( \frac{f_u}{\sqrt{3}} \right) \times (n_n A_{nb} + n_s A_{sb})}{\gamma_{mb}}$$

Where,

- $f_u$  = ultimate tensile stress of a bolt → depends on grade of bolts
- $n_n$  = Number shear planes with threads intercepting the shear plane;
- $n_s$  = Number of shear planes without threads intercepting the shear plane;
- $A_{sb}$  = Nominal plain shank area of the bolt; and





$A_{nb}$  = Net area of the bolt at threads, may be taken as the area corresponding to root diameter at the thread.

$\gamma_{mb}$  = partial safety factor for materials – bolt bearing, P- 30, Table – 5.

**GRADE OF BOLT:**

**i) Property class 4.6 (black bolt/ ordinary bolts/unfinished bolts)**

Number before decimal indicates 1/100<sup>th</sup> of the nominal ultimate strength and the number after decimal indicate the ratio of yield stress to ultimate stress, expressed as a percentage. i.e.,

Ultimate tensile stress = 400 N/mm<sup>2</sup>  
 Yield stress = 0.6 x 400 = 240 N/mm<sup>2</sup>

**ii) Property class 5.6**

Ultimate tensile stress = 500 N/mm<sup>2</sup>  
 Yield stress = 0.6 x 500 = 300 N/mm<sup>2</sup>

**iii) Property class 8.8**

Ultimate tensile stress = 800 N/mm<sup>2</sup>  
 Yield stress = 0.8 x 800 = 640 N/mm<sup>2</sup>  
 Grade of Plate or Material grade =  $f_u = 410$  N/mm<sup>2</sup>

As per IS 1367 (Part -1)

$$A_{sb} = \frac{\pi}{4} \times d^2$$

$A_{nb} = \frac{\pi}{4} \times (d - 0.9382p)^2$   $p$  = Course pitch of threads = 2, 2.5, 3 and 3.5 mm for 16, 20, 24 and 30 mm dia bolts respectively.

OR

$$A_{nb} = 0.78 \times \frac{\pi}{4} \times d^2$$

Threads in the shear plane

- The shear plane is the plane between two or more pieces under two or more pieces under load where the pieces tend to move parallel from each other, but in opposite directions.
- The threads of a bolt may either be included in the shear plane or excluded from the shear plane.
- The capacity of a bolt is greater with the threads excluded from the shear plane.

**Note:**

- If thread is interfering the shear plane in case of lap joint

$$n_n = 1, \quad \& \quad n_s = 0.$$

If Shank is interfering the shear plane in case of lap joint

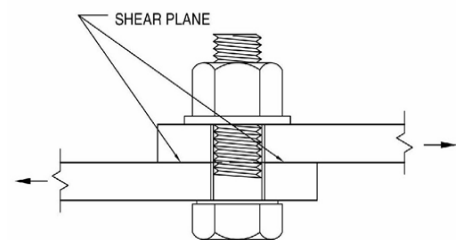

Threads Included In The Shear Plane

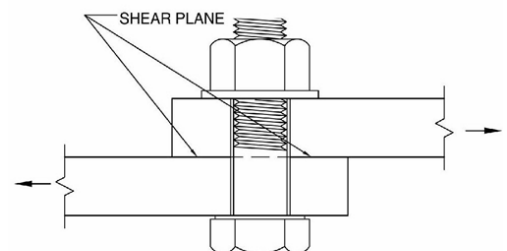

Threads Excluded From The Shear Plane



$$n_n = 0, \quad \& \quad n_s = 1.$$

➤ If Thread and Shank are interfering the shear plane as in case of butt joint

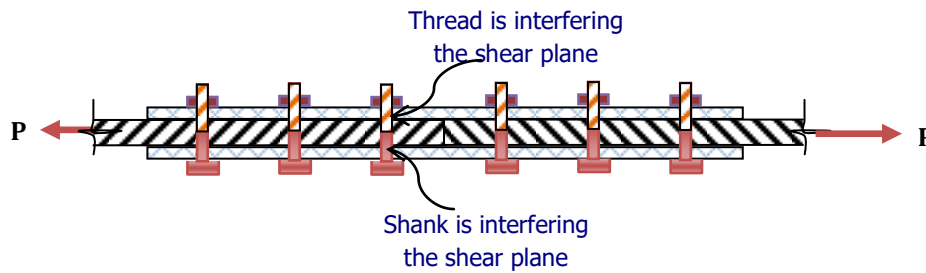

$$n_n = 1, \quad \& \quad n_s = 1.$$

**LAP JOINT:**

Strength of bolted joint against shearing of bolts :

$$V_{dsb} = N \times \left( \frac{f_u}{\sqrt{3}} \right) \times \left( \frac{n_n A_{nb} + n_s A_{sb}}{\gamma_{mb}} \right)$$

When the strength of bolted joint against the shearing of the bolts is determined per gauge width of the plate, then, the number of bolts, 'n' per gauge is taken into consideration. Therefore

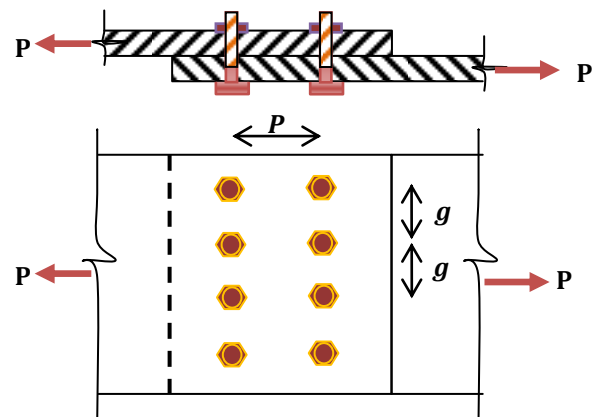

Strength of bolted joint against shearing of bolts per gauge width

$$V_{dsb-1} = n \times \left( \frac{f_u}{\sqrt{3}} \right) \times \left( \frac{n_n A_{nb} + n_s A_{sb}}{\gamma_{mb}} \right)$$

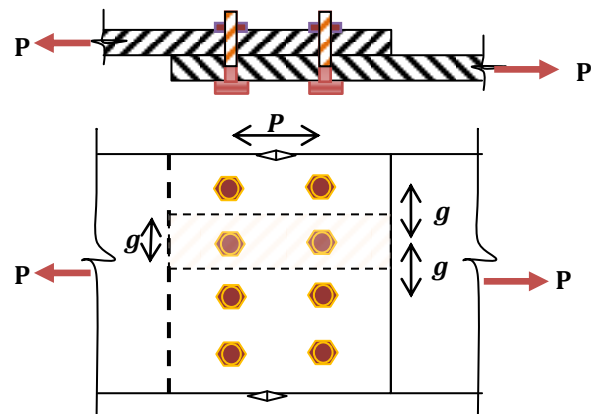

**BUTT JOINT:**

Strength of bolted joint against shearing of bolts

$$V_{dsb} = N \times \left[ \left( \frac{f_u}{\sqrt{3}} \right) \times \left( \frac{n_n A_{nb} + n_s A_{sb}}{\gamma_{mb}} \right) \right]$$

Where,

N = Number of bolts on each side of the joint

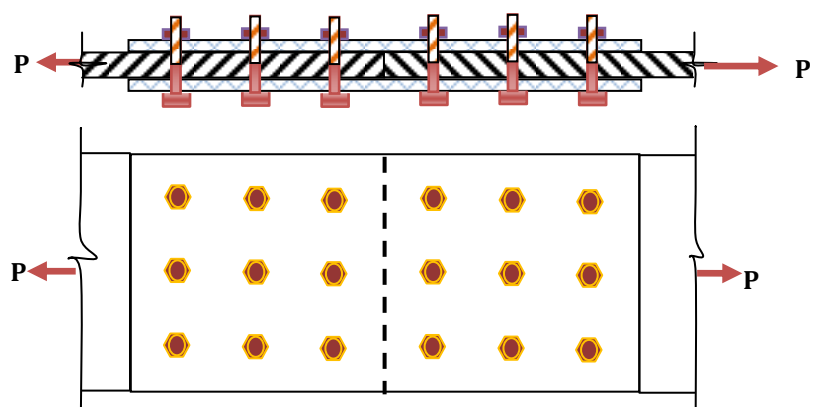



**Strength of the bolt in Double shear per gauge width:**

$$V_{dsb-1} = n \times \left[ \left( \frac{f_u}{\sqrt{3}} \right) \times \left( \frac{n_n A_{nb} + n_s A_{sb}}{\gamma_{mb}} \right) \right]$$

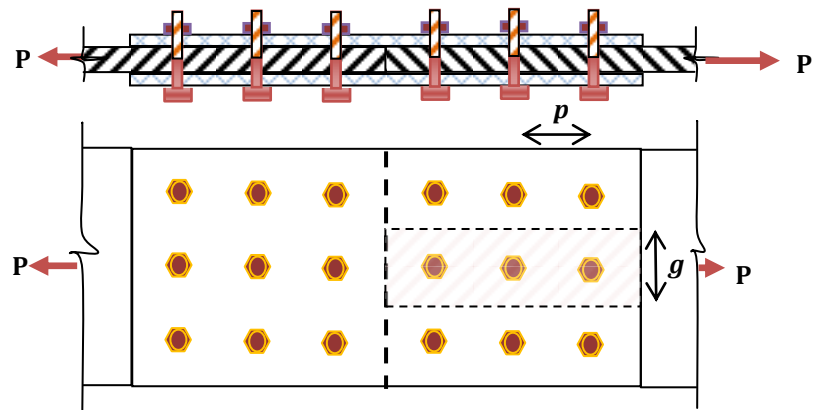

**2. Strength of bolted joint against the bearing of the bolts  $V_{dpb}$  (CI 10.3.4, P- 75)**

**Bolted joint failure mode**

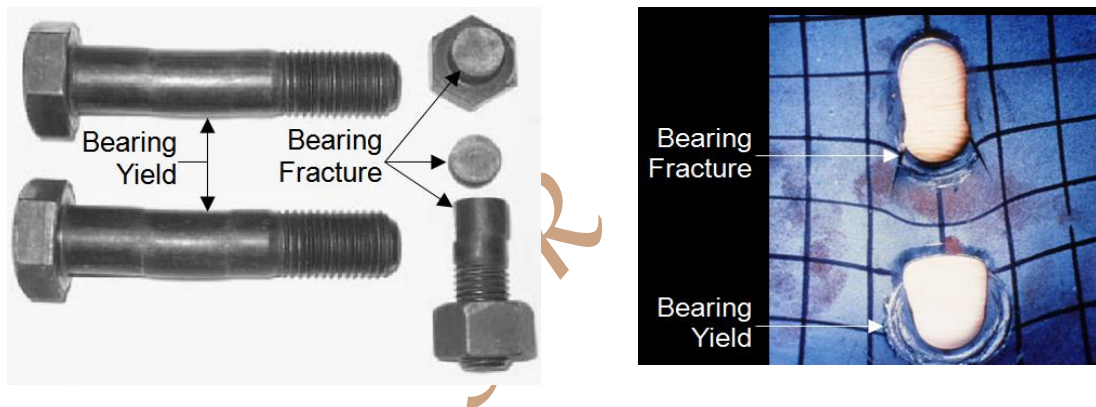

- Bolts in bearing joints are designed to meet two limit states:
  1. Yielding, which is an inelastic deformation.
  2. Fracture, which is a failure of the joint.
- The material the bolt bears against is also subjected to yielding or fracture if it is undersized for the load.
- Tension connection act similarly to bearing connections.
- Many times, connection in direction tension are reconfigured so that the bolts act in shear.

Strength of one bolt in bearing  $V_{dpb} = \frac{V_{npb}}{\gamma_{mb}}$

$$V_{dpb} = \frac{2.5 k_b \times d \times t^* \times f_u}{\gamma_{mb}}$$

Where,

- $f_u$  = Ultimate stress of the bolt
- $t^*$  = Thickness of the thinnest plate



**In case of lap joint:**

- Min of  $t_1, t_2$ .  
i.e.,  $t^* = t_1 = 8 \text{ mm}$

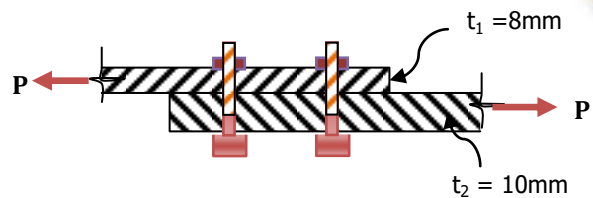

- $t^* = \text{Min thickness of}$
- a) Thickness of mainplate = 12 mm
- b) Sum of the thickness of cover plate =  $8 + 10 = 18 \text{ mm}$  i.e.,  $t^* = 12 \text{ mm}$

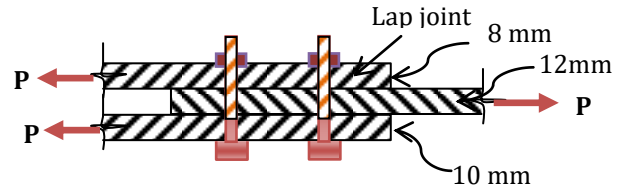

- Min of  $t_1, t_2$ .  
i.e.,  $t^* = t_1 = 10 \text{ mm}$

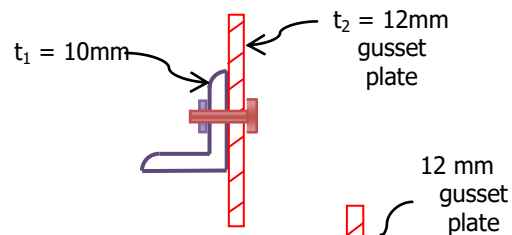

- $t^* = \text{Min thickness of}$
- a) Thickness of gusset plate = 12 mm
- b) Sum of the thickness of angles =  $8 + 8 = 16 \text{ mm}$   
i.e.,  $t^* = 12 \text{ mm}$

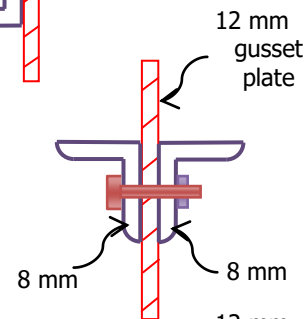

- $t^* = \text{Min thickness of}$
- a) Thickness of gusset plate = 12 mm
- b) Sum of the thickness of angles =  $5 + 5 = 10 \text{ mm}$   
i.e.,  $t^* = 10 \text{ mm}$

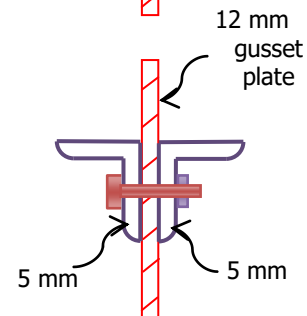

**In case of butt joint with double cover:**

- $t^* = \text{Min thickness of}$
- a) Thickness of main plate = 16 mm
  - b) Sum of the thickness of cover plate =  $10 + 10 = 20 \text{ mm}$   
i.e.,  $t^* = 16 \text{ mm}$

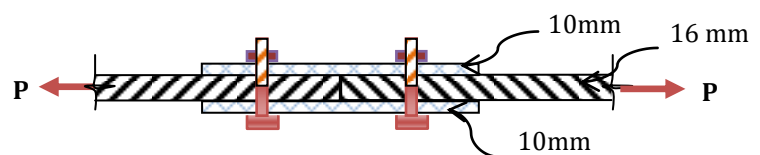

- $t^* = \text{Min thickness of}$
- a) Thickness of main plate = 16 mm
  - b) Sum of the thickness of cover plate =  $6 + 6 = 12 \text{ mm}$   
i.e.,  $t^* = 12 \text{ mm}$

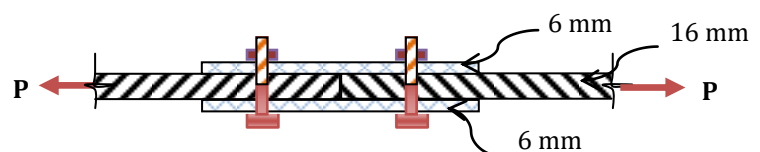

$d = \text{Nominal diameter of the bolt}$



$k_b$  = Smaller of the following

$$\left(\frac{e}{3d_o}\right), \quad \left(\frac{p}{3d_o}\right) - 0.25, \quad \left(\frac{f_{ub}}{f_u}\right), \quad \text{and } 1$$

$e$  = edge distance

$p$  = pitch of the fastener along the bearing direction

$d_o$  = dia of the bolt hole

**Note:**  $f_{ub}$  = Ultimate stress of the bolt {400 N/mm<sup>2</sup> (grade 4.6)/ 500 N/mm<sup>2</sup> (grade 5.6)/ 800 N/mm<sup>2</sup>(grade 8.8)/}  
 $f_u$  = Ultimate stress of the plate in MPa. (410 N/mm<sup>2</sup>)

The strength of bolted joint against the bearing of bolts is equal to the product of strength of one bolt in bearing and the number of bolts on each side of the joint.

Strength of bolted joint against the bearing of bolts

$$V_{dpb} = N \times \left( \frac{2.5k_b \times d \times t^* \times f_u}{\gamma_{mb}} \right)$$

When the strength of bolted joint against the bearing of bolts **per gauge** width of the plate is taken into consideration, then, the number of bolts,  $n$  per gauge. Therefore

$$V_{dpb-1} = n \times \frac{(2.5k_b \times d \times t^* \times f_u)}{\gamma_{mb}}$$

### 3. Strength of plate in tearing ( $T_{dn}$ ) P-32, Cl: 6.3.1

The strength of plate in tearing depends upon the resisting section of the plate.

The strength of the plate in tearing

$$T_{dn} = \frac{0.9A_n f_u}{\gamma_{m1}}$$

Where,

$f_u$  = ultimate stress of the material (plate) = 410 N/mm<sup>2</sup>.

$\gamma_{m1}$  = Partial safety factor for failure at ultimate stress = 1.25, P-30.

$A_n$  = Net area of the member.

The strength of the plate in tearing for full width of the plate

$$T_{dn} = \frac{0.9(b - nd_o) \times t \times f_u}{\gamma_{m1}}$$

$n$  = No of holes along the tearing line.

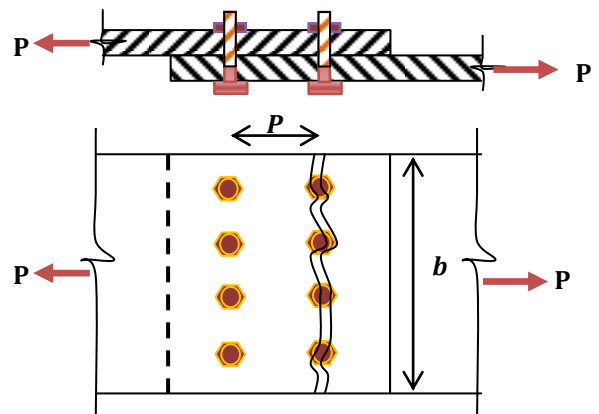



Strength of plate in tearing **per gauge width** of the plate

$$T_{dn-1} = \frac{0.9(p - d_0) \times t \times f_u}{\gamma_{m1}} \quad \text{or}$$

$$T_{dn-1} = \frac{0.9(g - d_0) \times t \times f_u}{\gamma_{m1}}$$

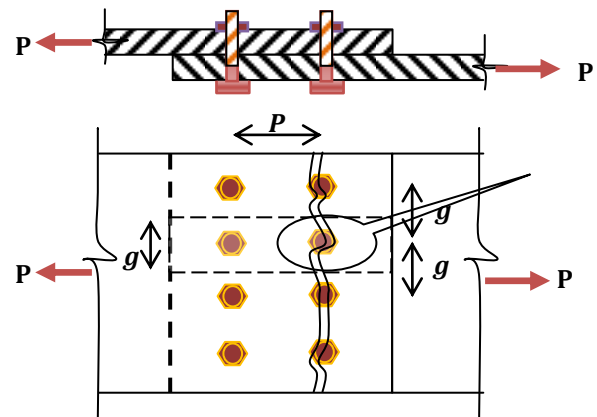

**The strength of bolted joint per gauge width of plate is the least of  $V_{dsb-1}$ ,  $V_{dpb-1}$ , and  $T_{dn-1}$**

### EFFICIENCY OF JOINTS ( $\eta$ )

Holes are drilled in the plates for the connection with bolts, hence the original strength of the full section is reduced. The joint which causes minimum in strength is said to be more efficient. Thus, for better efficiency the section should have the least no of holes at the critical section. The efficiency, expressed in percentage, is the ratio of actual strength of the connection to the gross strength of the connected members.

Efficiency of bolted joint per pitch length ( $\eta$ )

$$\eta = \frac{\text{Strength of bolted joint per pitch length}}{\text{Strength of solid plate per pitch length}} \times 100$$

Where, Strength of solid plate per pitch length =  $\frac{0.9 \times p \times t \times f_u}{\gamma_{mb}}$

$$\eta = \frac{\text{Least of } V_{dsb-1}, V_{dpb-1} \text{ or } T_{dn-1}}{V}$$

Efficiency of bolted joint ( $\eta$ ) =  $\frac{\text{Strength of bolted joint}}{\text{Strength of solid plate}} \times 100$

Strength of solid plate for full width =  $\frac{0.9 \times b \times t \times f_u}{\gamma_{mb}}$

$$\eta = \frac{\text{Least of } V_{dsb}, V_{dpb} \text{ or } T_{dn}}{V}$$

### Bolt Value (BV):

The strength of a bolt in **shearing** and in **bearing** is computed and the **lesser** is called the **Bolt value (BV)** (i.e., Least of  $V_{nsb}$  and  $V_{npb}$ )

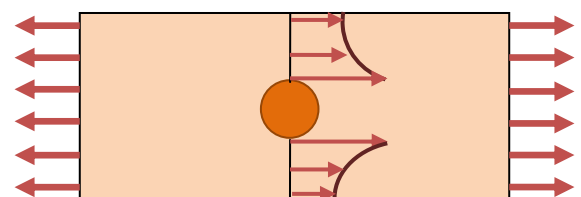





$$\text{No of bolts} = \frac{\text{Force}}{\text{Bolt value}}$$

**The assumptions made in the theory of bolted connections are:**

- 1) Shear is uniform on the cross section of the bolt.
- 2) Distribution of tensile stress on the portions of the plate between the bolt holes is uniform.
- 3) Bolts in a group subjected to direct load through their centroid share the load equally.
- 4) Bending stresses in the bolt are neglected.

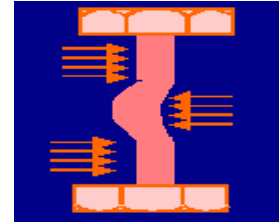

**Advantages and disadvantages of Bolted connection:**

The following are the **advantages** of bolted connections over riveted or welded connections:

- 1) Making joints is noiseless.
- 2) Do not need skilled labour
- 3) Needs less labour.
- 4) Connections can be made quickly.
- 5) Structures can be put to use immediately.
- 6) Accommodates minor discrepancies in dimensions.
- 7) Alterations, if any, can be done easily.
- 8) Working area required in the field is less.

The **disadvantages** of unfinished (black) bolt connections are:

- 1) Tensile strength is reduced considerably due to stress concentrations and reduction of area at the root of the threads.
- 2) Rigidity of joints is reduced due to loose fit, resulting into excessive deflections.
- 3) Due to vibrations nuts are likely to loosen, endangering the safety of the structures.

**Common definitions:**

**1) Nominal diameter.** It is the diameter of the bolt.

The dia of bolt for a given plate thickness is chosen by the **Unwins** formula:

$$d = 6.04\sqrt{t}$$

Where, t = thickness of plate in mm.

The bolts are available from 5 to 36 mm in diameter. The common ones are M16, M20, M24 to M30.

**Bolt Hole (d<sub>0</sub>):(Clause 10.2.1, P- 73).**

Bolts may be located in standard size, over size, short slotted or long slotted hole.

Table 19 gives the details of clearances for fastener holes.

Size of the hole = Nominal Diameter of the fastener + Clearances

Size of the hole = Nominal Diameter of the fastener + Clearances



Table 19

SI No	Nominal size of fastener, d mm	Size of the hole = Nominal Diameter of the fastener + clearances			
		Standards clearance in Diameter and width of slot	Over size clearance in Diameter	Clearance in the length of the slot	
				Short slot	Long Slot
i)	12 – 14	1.0	3.0	4.0	2.5 d
ii)	16 -22	2.0	4.0	6.0	2.5 d
iii)	24	2.0	6.0	8.0	2.5 d
iv)	Larger than 24	3.0	8.0	10.0	2.5 d

**(P-73, IS 800 – 2007) Bolts and Bolting:**

**Pitch of the bolt:**

Centre to centre distance between two adjacent bolts in a given row is called a pitch of a bolt.

**Clause 10.2.2**

a. **Minimum Pitch** – The distance between centres of bolts should be not less than 2.5 times the nominal diameter of the bolt.

**b. Maximum Pitch (Clause 10.2.3)**

**Clause 10.2.3.1**

i) The distance between centres of any two adjacent bolts (including tacking bolts) shall not exceed 32 t or 300 mm, whichever is less, where t is the thickness of the thinner outside plate.

**Clause 10.2.3.2**

ii) The distance between centres of two adjacent bolts, in a line lying in the direction of stress, shall not exceed 16 t or 200 mm, whichever is less in tension members and 12 t or 200 mm, whichever is less in compression members. In the case of compression members in which forces are transferred through butting faces, this distance shall not exceed 4.5 times the diameter of the bolts for a distance equal to 1.5 times the width of the member from the a butting faces.

**Clause 10.2.3.3**

iii) The distance between centres of any two consecutive bolts in a line adjacent and parallel to an edge of an outside plate shall not exceed (100 mm + 4t) or 200 mm, whichever is less in compression or tension members.

**Clause 10.2.3.4**

iv) When bolts are staggered at equal intervals and the gauge does not exceed 75 mm, the distances specified in (ii) and (iii) between centres of bolts, may be increased by 50 percent subjected maximum spacing specified in 10.2.3.1.

**Clause 10.2.4.2 Edge and End Distance**

The minimum edge and end distances from the centre of any hole to the nearest edge of a plate shall not be less than 1.7 times the hole diameter in case of sheared



or hand – flame cut edges; and 1.5 times the hole diameter in case of rolled, machine- flame cut, swan and planed edges.

**Clause 10.2.5.2 Tacking Bolts -**

Tacking bolts shall have spacing in line not exceeding 32 times the thickness of the thinner outside plate or 300 mm, whichever is less. Where the plates are exposed to the weather, the pitch in line shall not exceed 16 times, the thickness of the outside plate or 200 mm, whichever is less. In both cases, the lines of bolts shall not be apart at a distance greater than these pitches.

**Clause 10.2.5.4:** In tension members composed of two flats, angles, channels or less in contact back-to-back or separated back-to-back by a distance not exceeding the aggregate thickness of the connected parts, tacking bolts, with solid distance pieces where the parts are separated, shall be provided at pitch in line not exceeding 1000 mm.

**Clause 10.2.5.5:** For compression members, tacking bolts in a line shall be spaced at a distance not exceeding 600mm.

**Design procedure for bolted joint:**

Following are the steps for the design of a bolted joint:

1) The size of the bolt is determined by using **Unwins** formula:

$$d = 6.04\sqrt{t}$$

Where, t = thickness of plate in mm, d = dia of bolt in mm.

2) Determine Bolt value (BV)

It is the least of the following

a) Strength of one bolt in single shear or double shear

$$V_{dsb} = \left[ \left( \frac{f_u}{\sqrt{3}} \right) \times \left( \frac{n_n A_{nb} + n_s A_{sb}}{\gamma_{mb}} \right) \right]$$

or

$$\text{Strength of one bolt in Double shear } V_{dsb} = \left[ \left( \frac{f_u}{\sqrt{3}} \right) \times \left( \frac{n_n A_{nb} + n_s A_{sb}}{\gamma_{mb}} \right) \right]$$

b) Strength of one bolt in bearing

$$V_{dpb} = \frac{2.5k_b \times d \times t^* \times f_u}{\gamma_{mb}}$$

3) No of bolts =  $\frac{\text{Force}}{\text{Bolt value}}$

The number of bolts so obtained is provided on one side of the joint and an equal number of bolts is provided on the other side of the joint also.

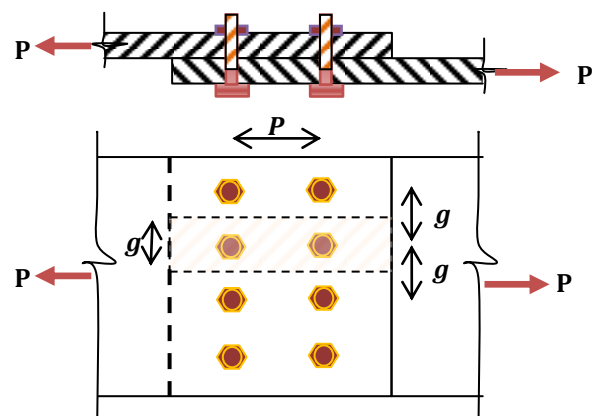



- 4) If gauge distance is to be determined for lap joint or butt joint, tearing strength of plate is determined which should be less than or equal to bolt value.

Strength of plate in tearing per gauge width of the plate

$$T_{dn-1} = \frac{0.9(g - d_o) \times t \times f_u}{\gamma_{m1}} \leq BV$$

From the above relation gauge distance can be determined

$$g = \frac{BV \times \gamma_{m1}}{0.9 \times t \times f_u} + d_o$$

**If pitch is required:**

Strength of plate in tearing per pitch

$$T_{dn-1} = \frac{0.9(p - d_o) \times t \times f_u}{\gamma_{m1}}$$

$$p = \frac{BV \times \gamma_{m1}}{0.9 \times t \times f_u} + d_o$$

- 5) If width of plate is to be determined, the strength of the plate in tearing for full width of the plate is equated to the force to be transmitted by the joint.

$$T_{dn} = \frac{0.9(b - nd_o) \times t \times f_u}{\gamma_{m1}} = \text{Pull/(Force)/(P)}$$

$$b = \frac{P \times \gamma_{m1}}{0.9 \times t \times f_u} + nd_o$$

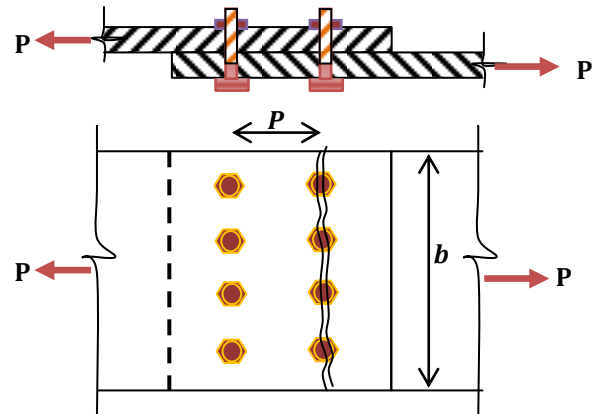

***n = no of holes along the failure section***

**6) Thickness of cover plate (in case of cover plate)**

$$t_c \neq \frac{5}{8} t \quad \text{for double cover butt joint}$$

$$t_c \neq \frac{9}{8} t \quad \text{for single cover butt joint}$$

where,  $t_c$  = Thickness of cover plates

$t$  = Thickness of main plate.

**Example**

Strength of bolted joint against shearing of bolts

$$V_{dsb} = N \left( \frac{f_u}{\sqrt{3}} \right) \times \left( \frac{n_n A_{nb} + n_s A_{sb}}{\gamma_{mb}} \right)$$

Strength of bolted joint against shearing of bolts

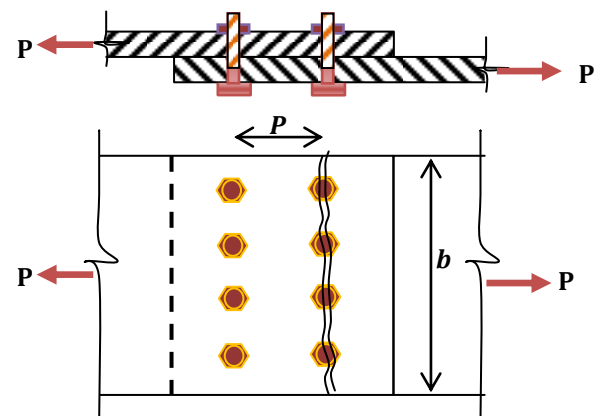



$$V_{dsb} = 8 \times \left( \frac{f_u}{\sqrt{3}} \right) \times \left( \frac{n_n A_{nb} + n_s A_{sb}}{\gamma_{mb}} \right)$$

Strength of bolted joint against the bearing of bolts

$$V_{dpb} = N \times \left( \frac{2.5k_b \times d \times t \times f_u}{\gamma_{mb}} \right)$$

Strength of bolted joint against the bearing of bolts

$$V_{dpb} = 8 \times \left( \frac{2.5k_b \times d \times t \times f_u}{\gamma_{mb}} \right)$$

The strength of the plate in tearing

$$T_{dn} = \frac{0.9(b - nd_0) \times t \times f_u}{\gamma_{m1}}$$

n = Number of holes along the tearing line = 4

The strength of the plate in tearing  $T_{dn} = \frac{0.9(b - 4d_0) \times t \times f_u}{\gamma_{m1}}$

**The strength of a bolted joint is the least of  $V_{dsb}$ ,  $V_{dpb}$  and  $T_{dn}$ .**

**Strength of bolted joint per gauge width of plate**

Strength of bolt in single shear per gauge width

$$V_{dsb-1} = n \times \left( \frac{f_u}{\sqrt{3}} \right) \times \left( \frac{n_n A_{nb} + n_s A_{sb}}{\gamma_{mb}} \right)$$

Strength of bolt in single shear per gauge width

$$V_{dsb-1} = 2 \times \left( \frac{f_u}{\sqrt{3}} \right) \times \left( \frac{n_n A_{nb} + n_s A_{sb}}{\gamma_{mb}} \right)$$

Strength of bolt in bearing per gauge width

$$V_{dpb-1} = \frac{n \times (2.5k_b \times d \times t \times f_u)}{\gamma_{mb}}$$

Strength of bolt in bearing per gauge width

$$V_{dpb-1} = \frac{2 \times (2.5k_b \times d \times t \times f_u)}{\gamma_{mb}}$$

Strength of plate in tearing per gauge width of the plate

$$T_{dn-1} = \frac{0.9(g - nd_0) \times t \times f_u}{\gamma_{m1}} = \frac{0.9(g - 1 \times d_0) \times t \times f_u}{\gamma_{m1}}$$

n = Number of holes along the tearing line per gauge length = 1

Strength of plate in tearing per pitch

$$T_{dn-1} = \frac{0.9(p - d_0) \times t \times f_u}{\gamma_{m1}}$$

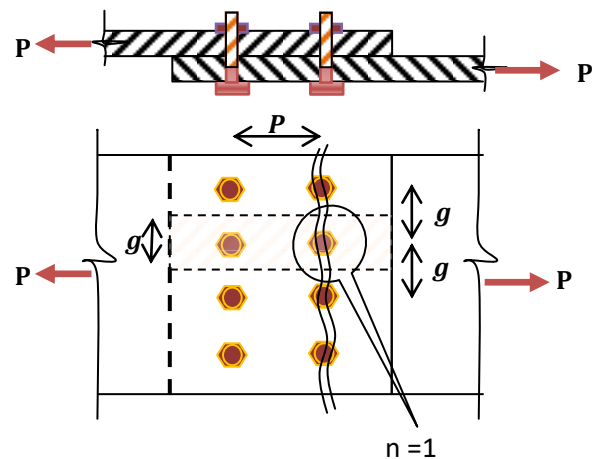



*The strength of bolted joint per gauge width of plate is the least of  $V_{dsb-1}$ ,  $V_{dpb-1}$  and  $T_{dn-1}$ .*

**Strength of bolted Butt Joint**

Strength of bolted joint against shearing of bolts

$$V_{dsb-2} = N \times \left[ \left( \frac{f_u}{\sqrt{3}} \right) \times \left( \frac{n_n A_{nb} + n_s A_{sb}}{\gamma_{mb}} \right) \right]$$

Where, N = Number of bolts on each side of the joint

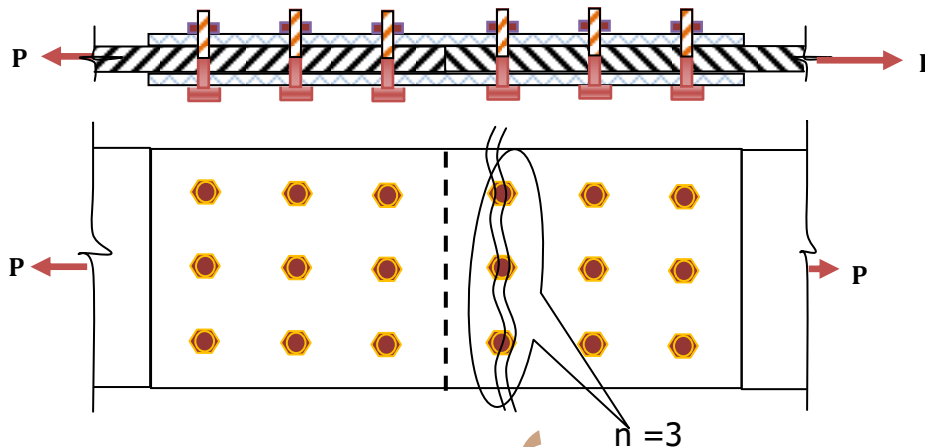

Strength of bolted joint against shearing of bolts

$$V_{dsb-2} = 9 \times \left[ \left( \frac{f_u}{\sqrt{3}} \right) \times \left( \frac{n_n A_{nb} + n_s A_{sb}}{\gamma_{mb}} \right) \right]$$

Strength of bolted joint against the bearing

$$V_{dpb-2} = N \times \left( \frac{2.5 \times k_b \times d \times t \times f_u}{\gamma_{mb}} \right)$$

Strength of bolted joint against the bearing

$$V_{dpb-2} = 9 \times \left( \frac{2.5 \times k_b \times d \times t \times f_u}{\gamma_{mb}} \right)$$

Strength of the plate in tearing

$$T_{dn-2} = \frac{0.9(b - nd_0) \times t \times f_u}{\gamma_{m1}}$$

Strength of the plate in tearing

$$T_{dn-2} = \frac{0.9(b - 3d_0) \times t \times f_u}{\gamma_{m1}}$$

*The strength of bolted butt joint per gauge width of plate is the least of  $V_{dsb-2}$ ,  $V_{dpb-2}$  and  $T_{dn-2}$ .*





**Strength of the bolt in double shear per gauge width**

Strength of bolt in Double shear per gauge width

$$V_{dsb-1} = n \times \left[ \left( \frac{f_u}{\sqrt{3}} \right) \times \left( \frac{n_n A_{nb} + n_s A_{sb}}{\gamma_{mb}} \right) \right]$$

Strength of bolt in Double shear

$$V_{dsb-1} = 3 \times \left[ \left( \frac{f_u}{\sqrt{3}} \right) \times \left( \frac{n_n A_{nb} + n_s A_{sb}}{\gamma_{mb}} \right) \right]$$

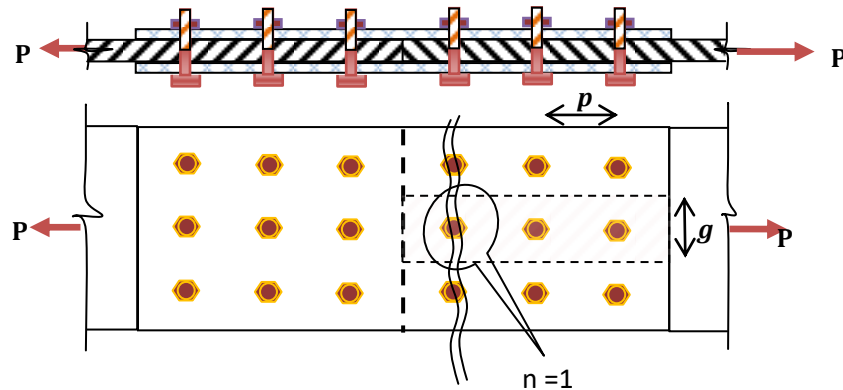

Strength of bolt in Bearing per gauge width

$$V_{dpb-1} = \frac{n \times (2.5k_b \times d \times t \times f_u)}{\gamma_{mb}}$$

Strength of bolt in Bearing per gauge width

$$V_{dpb-1} = \frac{3 \times (2.5k_b \times d \times t \times f_u)}{\gamma_{mb}}$$

Strength of plate in tearing per gauge width of the plate

$$T_{dn-1} = \frac{0.9(g - d_0) \times t \times f_u}{\gamma_{m1}}$$

Strength of plate in tearing per pitch

$$T_{dn-1} = \frac{0.9(p - d_0) \times t \times f_u}{\gamma_{m1}}$$

**The strength of bolted butt joint per gauge width of plate is the least of  $V_{dsb-1}$ ,  $V_{dpb-1}$ , and  $T_{dn-1}$ .**

**High Strength Friction Grip Bolts: (HSFG)**

The HSFG bolts are made from high strength steel rods. The surface of the shank is kept unfinished as in the case of black bolts. These bolts are tightened to a proof load using calibrated wrenches. Hence they grip the members tightly. In addition nuts are prevented by using clamping devices. If the joint is subjected to shearing load it is primarily resisted by frictional force between the members and washers. The shank of the bolts is not subjected to any shearing. This result into no slippage in the joint. Hence such bolts can be used to connect members subjected to dynamic loads also. Commonly available nominal diameter of HSFG bolts are 16, 20, 24, 30 and 36 mm.

For commonly used HSFG bolts (Grade 8.8),

Ultimate stress  $f_{ub} = 800 \text{ N/mm}^2$ , and yield stress  $f_{yb} = 0.8 \times 800 = 640 \text{ N/mm}^2$ .



**Shear capacity (P - 76, Cl 10.4)**

**1) No slip condition: (Friction bolts)**

Shear capacity :

$$V_{dsf} = \frac{V_{nsf}}{\gamma_{mf}} = \frac{\mu_f n_e k_h F_o}{\gamma_{mf}}$$

$\mu_f$  = Friction co-efficient (Slip factor) = 0.55 ,

if specific condition of surface treatment is given ref Table 20 of Page – 77.

$n_e$  = Number of effective interfaces offering frictional resistance to slip

$n_e = 1$  for single shear

$n_e = 2$  for double shear (Butt joint with 2 cover plates)

$$k_h = 1$$

$K_h = 1$  for standard clearance hole,

$K_h = 0.85$  for oversized or short slotted,

$K_h = 0.7$  for long slotted hole,

$$\text{Proof Load } F_o = A_{nb} \times f_o$$

$$\text{Proof Stress } f_o = 0.7f_{ub}$$

$$A_{nb} = \text{Area of thread} = 0.78 \times \frac{\pi \times d^2}{4}$$

$$\gamma_{mf} = 1.1 \text{ (Service load)}$$

**2) Slip condition: (Bearing bolts)**

Shear capacity

$$V_{dsf} = \frac{V_{nsf}}{\gamma_{mf}} = \frac{\mu_f n_e k_h F_o}{\gamma_{mf}}$$

$$\gamma_{mf} = 1.25 \text{ (Ultimate load)}$$

**Problem:**

Determine the shear capacity of bolts used in connecting two plates as shown in fig.

if (i) Slip resistance is designated at service load

(ii) Slip resistance is designated at ultimate load

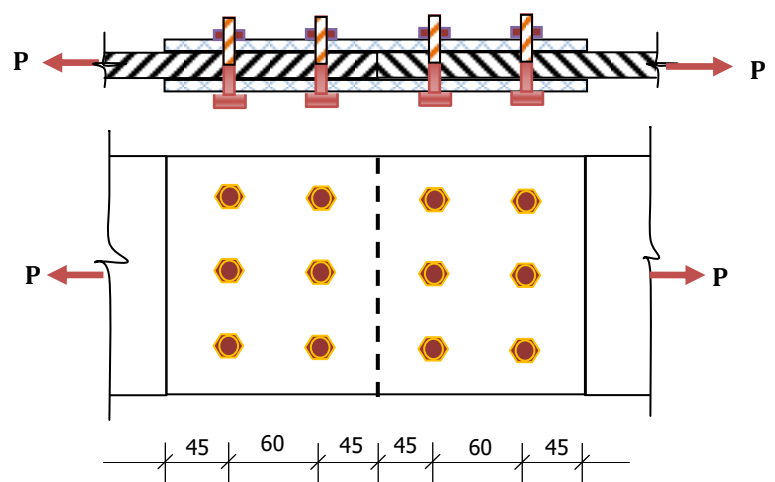

Given:

- i. HSFG bolts of grade 8.8 are used.
- ii. Fasteners are in clearance holes.
- iii. Coefficient of friction = 0.3.

**Solution:**

For HSFG bolts of Grade 8.8

Ultimate stress  $f_{ub} = 800 \text{ N/mm}^2$ ,

Coefficient of friction  $\mu_f = 0.3$ .



**Shear capacity :**

$$V_{dsf} = \frac{V_{nsf}}{\gamma_{mf}} = \frac{\mu_f n_e k_h F_o}{\gamma_{mf}}$$

$n_e$  = Number of effective interfaces offering frictional resistance to slip  
 $n_e = 2$  for double shear (Butt joint with 2 cover plates)

$$k_h = 1$$

$$\text{Proof Load } F_o = A_{nb} \times f_o$$

$$A_{nb} = \text{Area of thread} = 0.78 \times \frac{\pi \times d^2}{4} = 0.78 \times \frac{\pi \times 20^2}{4} = 245.04 \text{ mm}^2$$

$$\text{Proof Stress } f_o = 0.7 f_{ub} = 0.7 \times 800 = 560 \text{ N/mm}^2$$

$$\text{Proof Load } F_o = A_{nb} \times f_o = 245.04 \times 560 = 137.22 \times 10^3 \text{ N}$$

$$\gamma_{mf} = 1.1 \text{ (Service load)}$$

$$\gamma_{mf} = 1.25 \text{ (Ultimate load)}$$

**1) Design capacity of joint for Slip resistance designated at service load**

$$V_{dsf} = N \times \frac{V_{nsf}}{\gamma_{mf}} = N \times \frac{\mu_f n_e k_h F_o}{\gamma_{mf}} = 6 \times \frac{0.3 \times 2 \times 1 \times 137.22 \times 10^3}{1.1 \times 1000} = 449.09 \text{ kN}$$

**2) Design capacity of joint, if Slip resistance is designated at ultimate load**

$$V_{dsf} = N \times \frac{V_{nsf}}{\gamma_{mf}} = N \times \frac{\mu_f n_e k_h F_o}{\gamma_{mf}} = 6 \times \frac{0.3 \times 2 \times 1 \times 137.22 \times 10^3}{1.25 \times 1000} = 395.20 \text{ kN}$$

**Advantages of HSFG Bolts:**

1. Joints are rigid, i.e., No slip takes place in the joint.
2. As load transfer is mainly by friction, the bolts are not subjected to shearing and bearing stresses.
3. High static strength due to high frictional resistance.
4. Smaller number of bolts results in smaller size of gusset plate.

**Disadvantages of HSFG Bolts:**

1. Tensile strength is reduced considerably due to stress concentration and reduction of area at the root of the threads.
2. Rigidity of joints is reduced due to loose fit, resulting into excessive deflection
3. Due to vibrations joints are likely to loosen, endangering the safety of the structures.
4. Material cost is high.



**Ex 1:Ⓜ**

Two plates of 6 mm and 8 mm thick are connected by single bolted lap joint with 4–20 mm diameter bolts at 60 mm gauge width. Calculate the efficiency of the joint. Take  $f_u$  of plate as 410 MPa and assume 4.6 grade bolts. Take end distance = 35 mm.

**Solution:**

Dia of bolt  $d = 20$  mm

Dia of hole  $= d_o = 20 + 2 = 22$  mm

Gauge distance ( $g$ ) = 60 mm,  $e = 35$  mm

$f_u$  of plate = 410 MPa

For 4.6 grade of bolt

$f_u$  of bolt = 400 MPa

$b = 2 \times 35 + 3 \times 60 = 250$  mm

$t = 6$  mm (Min thickness of 6mm and 8mm)

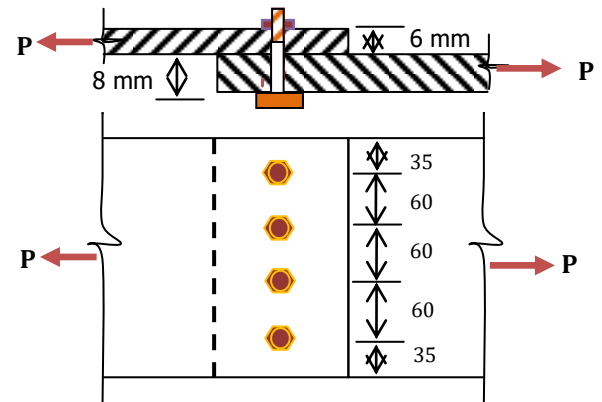

**1) Strength of bolt in Single shear(P-75, Cl: 10.3.3)**

$$V_{dsb} = N \times \left( \frac{f_u}{\sqrt{3}} \right) \times \left( \frac{n_n A_{nb} + n_s A_{sb}}{\gamma_{mb}} \right)$$

No of bolts  $N = 4$ .

Assuming Shank is interfering the shear plane

$n_n = 0$        $n_s = 1$  ,  $\gamma_{mb} = 1.25$

$$A_{sb} = \frac{\pi}{4} (d)^2 = \frac{\pi}{4} (20)^2 = 314.16 \text{ mm}^2,$$

$$V_{dsb} = 4 \times \frac{400}{\sqrt{3}} \times \left( \frac{0 + 1 \times 314.16}{1.25 \times 1000} \right) = 232.16 \text{ kN}$$

**2) Strength of bolt in Bearing**  $V_{dpb} = N \times \frac{2.5 \times k_b \times d \times t \times f_u}{\gamma_{mb}}$

$k_b$  is the least of the following:

1)  $\frac{e}{3d_0} = \frac{35}{3 \times 22} = 0.53$

2)  $\frac{p}{3d_0} - 0.25 = \frac{60}{3 \times 22} - 0.25 = 0.66$

3)  $\frac{f_{ub}}{f_u} = \frac{400}{410} = 0.98$       4) 1

$$V_{dpb} = 4 \times \frac{2.5 \times 0.53 \times 20 \times 6 \times 400}{1.25 \times 1000} = 203.53 \text{ kN}$$

**3) Strength of plate in tearing**

$$T_{dn} = \frac{0.9 A_n \times t \times f_u}{\gamma_{m1}}$$

$n =$  No of bolts along tearing section = 4

$$T_{dn} = \frac{0.9(b - nd_0) \times t \times f_u}{\gamma_{m1}}$$

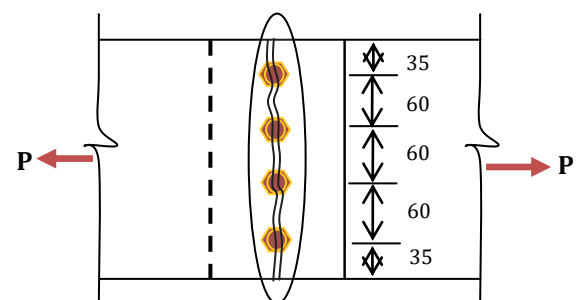



$$= \frac{0.9 \times (250 - 4 \times 22) \times 6 \times 410}{1.25 \times 1000} = 286.93 \text{ KN}$$

**The strength of bolted joint of plate is the least of  $V_{dsb}$ ,  $V_{dpb}$  and  $T_{dn}$ .**

$\therefore$  The strength of bolted joint = **203.52 KN**

$$\begin{aligned} \text{Strength of solid plate} &= \frac{0.9 \times b \times t \times f_u}{\gamma_{mb}} \\ &= \frac{0.9 \times 250 \times 6 \times 410}{1.25 \times 1000} = 442.8 \text{ KN} \end{aligned}$$

Efficiency of bolted joint ( $\eta$ ):  $\frac{\text{Strength of bolted joint}}{\text{Strength of solid plate}} \times 100$

$$\eta = \frac{203.53}{442.8} \times 100 = 45.96\%$$

### Ex – 2®:

Plates of 6 mm thick are connected by single bolted lap joint with 20 mm diameter bolts at 60 mm gauge width. Calculate the efficiency of the joint. Take  $f_u$  of plate as 410 MPa and assume 4.6 grade bolts.

**Solution:** Dia of bolt  $d = 20$  mm

Dia of hole =  $d_o = 20 + 2 = 22$  mm

Gauge distance ( $g$ ) = 60 mm

$f_u$  of plate = 410 MPa

For 4.6 grade of bolt

$f_u$  of bolt = 400 MPa

$t = 6$  mm

**1) Strength of joint in Single shear of bolts per gauge width (P-75, Cl: 10.3.3)**

$$V_{dsb} = n \times \left( \frac{f_u}{\sqrt{3}} \right) \times \left( \frac{n_n A_{nb} + n_s A_{sb}}{\gamma_{mb}} \right)$$

No of bolts  $n = 1$ .

Assuming thread is interfering the shear plane

$$n_n = 1 \quad n_s = 0, \quad \gamma_{mb} = 1.25$$

$$A_{nb} = 0.78 \times \frac{\pi}{4} (d)^2 = 0.78 \times \frac{\pi}{4} (20)^2 = 245.62 \text{ mm}^2,$$

$$V_{dsb1-1} = 1 \times \frac{400}{\sqrt{3}} \times \left( \frac{1 \times 245.62 + 0}{1.25 \times 1000} \right) = 45.27 \text{ KN}$$

**2) Strength of bolt in Bearing per gauge width**

$$V_{dpb} = n \times \frac{2.5 \times k_b \times d \times t \times f_u}{\gamma_{mb}}$$

$k_b$  is the least of the following:

$$1) \frac{e}{3d_o} \Rightarrow \text{NA} \quad 2) \frac{p}{3d_o} - 0.25 \Rightarrow \text{NA} \quad 3) \frac{f_{ub}}{f_u} = \frac{400}{410} = 0.98 \quad 4) 1$$

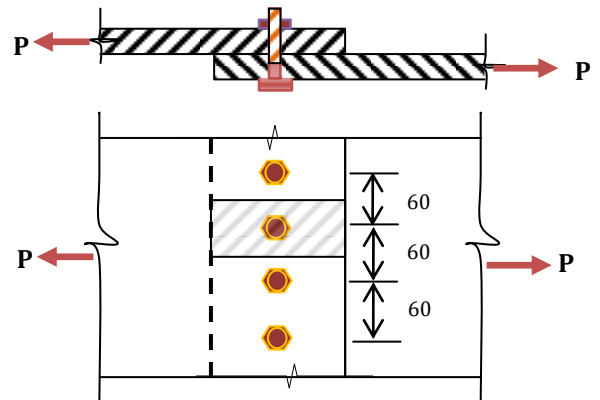



$$V_{d_{pb1-1}} = 1 \times \frac{2.5 \times 0.98 \times 20 \times 6 \times 400}{1.25 \times 1000} = 94.08 \text{ KN}$$

3) Strength of plate in tearing per gauge width

$$T_{dn1-1} = \frac{0.9(g - nd_0) \times t \times f_u}{\gamma_{m1}}$$

$$= \frac{0.9 \times (60 - 1 \times 22) \times 6 \times 410}{1.25 \times 1000}$$

$$T_{dn1-1} = 67.31 \text{ KN}$$

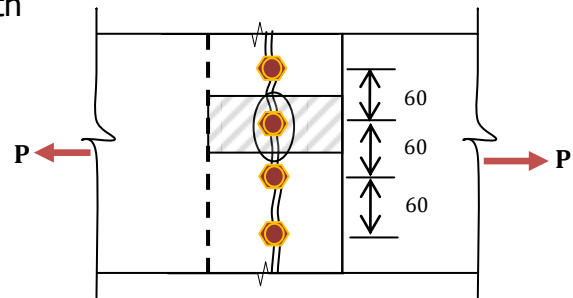

**The strength of bolted joint per gauge width of plate is the least of  $V_{dsb1-1}$ ,  $V_{d_{pb1-1}}$  and  $T_{dn1-1}$ .**

∴ The strength of bolted joint per gauge width = **45.27 KN**

$$\text{Strength of solid plate per gauge width} = \frac{0.9 \times g \times t \times f_u}{\gamma_{mb}}$$

$$= \frac{0.9 \times 60 \times 6 \times 410}{1.25 \times 1000} = 106.27 \text{ KN}$$

Efficiency of bolted joint per gauge ( $\eta$ ):  $\frac{\text{Strength of bolted joint per gauge}}{\text{Strength of solid plate per gauge}} \times 100$

$$\eta = \frac{45.27}{106.27} \times 100 = 42.60\%$$

**Example 3.®:** Find the maximum force which can be transmitted through the lap joint shown in the fig. Find also the efficiency of the joint. Take  $f_u$  of plate as 410 MPa and assume 5.6 grade bolts.

**Solution:**

$t = 15 \text{ mm}$  (Min of 15 mm and 18 mm)

Dia of bolt using Unwin's formula

$$d = 6.04\sqrt{t} = 6.04 \times \sqrt{15} = 23.39 \text{ mm}$$

Usually unwin's formula gives higher value, so diameter of bolt can be assumed lesser than calculated.

Say  $d = 20 \text{ mm}$

Table 19, P-73

Dia of hole =  $d_o = 20 + 2 = 22 \text{ mm}$

Gauge ( $g$ ) = 60 mm,  $e = 30 \text{ mm}$

$f_u$  of plate = 410 MPa

For 4.6 grade of bolt

$f_u$  of bolt = 500 MPa

$$b = 2 \times 30 + 2 \times 60 = 180 \text{ mm}$$

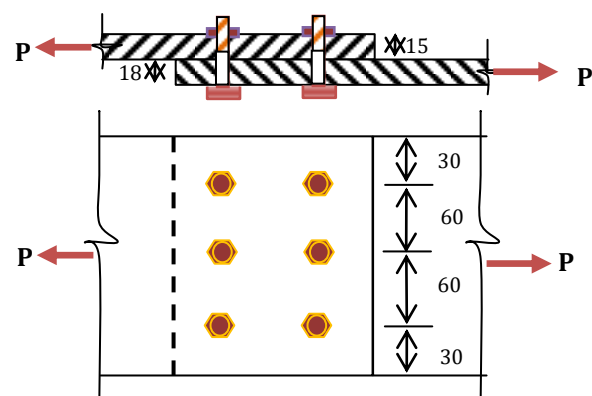

### 1) Strength of bolt in Single shear





$$V_{dsb} = N \times \left( \frac{f_u}{\sqrt{3}} \right) \times \left( \frac{n_n A_{nb} + n_s A_{sb}}{\gamma_{mb}} \right)$$

No of bolts  $N = 6$ .

Assuming Shank is interfering the shear plane

$$n_n = 0 \quad n_s = 1, \gamma_{mb} = 1.25$$

$$A_{sb} = \frac{\pi}{4} (d)^2 = \frac{\pi}{4} (20)^2 = 314.16 \text{ mm}^2,$$

$$V_{dsb} = 6 \times \frac{500}{\sqrt{3}} \times \left( \frac{0 + 1 \times 314.16}{1.25 \times 1000} \right) = 435.31 \text{ KN}$$

**2) Strength of bolt in Bearing**  $V_{dpb} = N \times \frac{2.5 \times k_b \times d \times t \times f_u}{\gamma_{mb}}$

$k_b$  is the least of the following:

$$1) \frac{e}{3d_0} = \frac{30}{3 \times 22} = 0.454 \quad 2) \frac{p}{3d_0} - 0.25 = \frac{60}{3 \times 22} - 0.25 = 0.66$$

$$P = 2.5 \times 20 = 50 \text{ mm Say } 60 \text{ mm}$$

$$3) \frac{f_{ub}}{f_u} = \frac{500}{410} = 1.22 \quad 4) 1$$

$$V_{dpb} = 6 \times \frac{2.5 \times 0.454 \times 20 \times 15 \times 500}{1.25 \times 1000} = 817.2 \text{ KN}$$

**3. Strength of plate in tearing**

$$T_{dn} = \frac{0.9(b - nd_0) \times t \times f_u}{\gamma_{m1}}$$

$$= \frac{0.9 \times (180 - 3 \times 22) \times 15 \times 410}{1.25 \times 1000} = 504.80 \text{ KN}$$

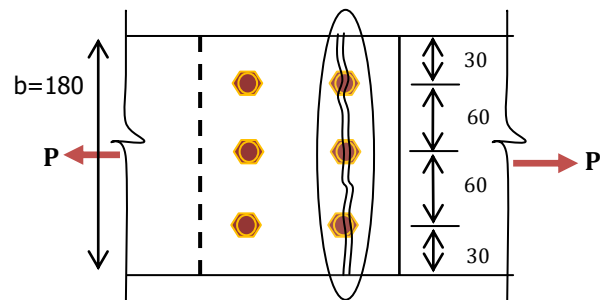

**The strength of bolted joint of plate is the least of  $V_{dsb}$ ,  $V_{dpb}$  and  $T_{dn}$ .**

$\therefore$  The strength of bolted joint = 384.25KN

$$\text{Strength of solid plate} = \frac{0.9 \times b \times t \times f_u}{\gamma_{mb}}$$

$$= \frac{0.9 \times 180 \times 15 \times 410}{1.25 \times 1000} = 797.04 \text{ KN}$$

Efficiency of bolted joint ( $\eta$ ):  $\frac{\text{Strength of bolted joint}}{\text{Strength of solid plate}} \times 100$

$$\eta = \frac{384.25}{797.04} \times 100 = 48.21 \%$$

**Example 4.®:** Find the maximum force which can be transmitted through the lap joint connection of 2 plates of 8 mm and 10 mm thick with 8 bolts at a pitch of 60 mm, gauge distance of 50 mm and edge distance of 35 mm. Also find the efficiency of the joint using bolts of property class 8.8.

**Solution:**



$t = 8 \text{ mm}$  (Min of 8 mm and 10 mm)

Dia of bolt using Unwin's formula

$$d = 6.04\sqrt{t} = 6.04 \times \sqrt{8} = 17.08 \text{ mm}$$

Say  $d = 16 \text{ mm}$

Table 19, P-73

Dia of hole =  $d_o = 16 + 2 = 18 \text{ mm}$

Pitch = 60 mm,  $e = 35 \text{ mm}$

$f_u$  of plate = 410 MPa

For 8.8 grade of bolt (HSFG bolt)

$f_u$  of bolt = 800 MPa

$$b = 2 \times 35 + 2 \times 50 = 170 \text{ mm}$$

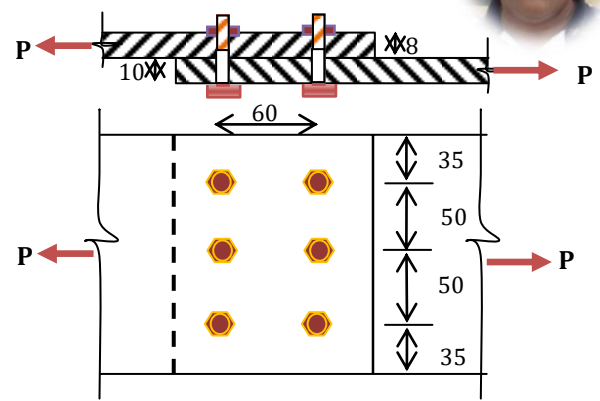

### 1) Strength of bolt in shear: P-76, Cl: 10.4

$$V_{dsf} = N \times \frac{V_{nsf}}{\gamma_{mf}} = N \times \frac{\mu_f n_e k_h F_o}{\gamma_{mf}}$$

No of bolts  $N = 6$ ,  $\mu_f = 0.55$ ,  $n_e = 1$ ,  $k_h = 1$

$$\text{Proof Load } F_o = A_{nb} \times f_o$$

$$A_{nb} = \text{Area of thread} = 0.78 \times \frac{\pi \times d^2}{4} = 0.78 \times \frac{\pi \times 16^2}{4} = 156.83 \text{ mm}^2$$

$$\text{Proof Stress } f_o = 0.7 f_{ub} = 0.7 \times 800 = 560 \text{ N/mm}^2$$

$$\text{Proof Load } F_o = A_{nb} \times f_o = 156.83 \times 560 = 87.82 \times 10^3 \text{ N}$$

$$V_{dsf} = 6 \times \frac{0.55 \times 1 \times 1 \times 87.82 \times 10^3}{1.1 \times 1000} = 263.46 \text{ kN}$$

### 2) Strength of bolt in Bearing

$$V_{dpb} = N \times \frac{2.5 \times k_b \times d \times t \times f_u}{\gamma_{mb}}$$

$k_b$  is the least of the following:

$$1) \frac{e}{3d_o} = \frac{35}{3 \times 18} = 0.65 \quad 2) \frac{p}{3d_o} - 0.25 = \frac{60}{3 \times 18} - 0.25 = 0.86$$

$$3) \frac{f_{ub}}{f_u} = \frac{800}{410} = 1.95 \quad 4) 1$$

$$V_{dpb} = 6 \times \frac{2.5 \times 0.65 \times 16 \times 8 \times 800}{1.25 \times 1000} = 798.72 \text{ kN}$$

### 3) Strength of plate in tearing:

$$T_{dn} = \frac{0.9(b - nd_o) \times t \times f_u}{\gamma_{m1}}$$

$$= \frac{0.9 \times (170 - 3 \times 18) \times 8 \times 410}{1.25 \times 1000} = 273.95 \text{ KN}$$

**The strength of bolted joint of plate is the least of  $V_{dsf}$ ,  $V_{dpb}$  and  $T_{dn}$ .**



$\therefore$  The strength of bolted joint = 263.46 kN

$$\begin{aligned} \text{Strength of solid plate} &= \frac{0.9 \times b \times t \times f_u}{\gamma_{mb}} \\ &= \frac{0.9 \times 170 \times 8 \times 410}{1.25 \times 1000} = 401.47 \text{ kN} \end{aligned}$$

Efficiency of bolted joint ( $\eta$ ):  $\frac{\text{Strength of bolted joint}}{\text{Strength of solid plate}} \times 100$

$$\eta = \frac{263.46}{401.47} \times 100 = 65.62 \%$$

**Example 5** ®: Find the maximum force per gauge width which can be transmitted through the lap joint shown in the fig. Find also the efficiency of the joint. Take  $f_u$  of plate as 410 MPa and assume 4.6 grade bolts.

**Solution:**

Dia of bolt using Unwin's formula

$$d = 6.04\sqrt{t} = 6.04 \times \sqrt{15} = 23.39 \text{ mm}$$

Say  $d = 20 \text{ mm}$

Table 19, P-73

Dia of hole =  $d_o = 20 + 2 = 22 \text{ mm}$

Pitch = 60 mm,  $e = 30 \text{ mm}$

$f_u$  of plate = 410 MPa

For 4.6 grade of bolt

$f_u$  of bolt = 400 MPa

### 1) Strength of bolt in Single shear

$$V_{dsb} = n \times \left( \frac{f_u}{\sqrt{3}} \right) \times \left( \frac{n_n A_{nb} + n_s A_{sb}}{\gamma_{mb}} \right)$$

No of bolts ( $n$ ) = 2.

Assuming Shank is interfering the shear plane

$$n_n = 0 \quad n_s = 1, \quad \gamma_{mb} = 1.25$$

$$A_{sb} = \frac{\pi}{4} (d)^2 = \frac{\pi}{4} (20)^2 = 314.16 \text{ mm}^2,$$

$$V_{dsb} = 2 \times \frac{400}{\sqrt{3}} \times \left( \frac{0 + 1 \times 314.16}{1.25 \times 1000} \right) = 116.08 \text{ kN}$$

### 2) Strength of bolt in Bearing

$$V_{dpb} = n \times \frac{2.5 \times k_b \times d \times t \times f_u}{\gamma_{mb}}$$

$k_b$  is the least of the following:

$$1) \frac{e}{3d_o} = \frac{35}{3 \times 22} = 0.53$$

$$e = 1.5 \times d_o = 1.5 \times 22 = 33 \text{ mm say } 35 \text{ mm}$$

$$2) \frac{p}{3d_o} - 0.25 = \frac{60}{3 \times 22} - 0.25 = 0.66$$

$$p = 2.5 \times 20 = 50 \text{ mm say } 60 \text{ mm}$$

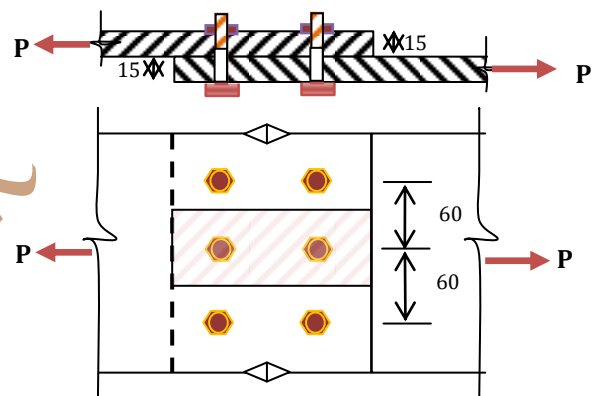



$$3) \frac{f_{ub}}{f_u} = \frac{400}{410} = 0.98 \quad 4) 1$$

$$V_{dpb} = 2 \times \frac{2.5 \times 0.53 \times 20 \times 15 \times 400}{1.25 \times 1000} = 254.4 \text{ kN}$$

**3) Strength of plate in tearing:**

$$T_{dn} = \frac{0.9(p - d_0) \times t \times f_u}{\gamma_{m1}} = \frac{0.9 \times (60 - 22) \times 15 \times 410}{1.25 \times 1000} = 168.26 \text{ kN}$$

*The strength of bolted joint of plate is the least of  $V_{dsb}$ ,  $V_{dpb}$  and  $T_{dn}$ .*

$\therefore$  The strength of bolted joint = 116.08 kN

$$\begin{aligned} \text{Strength of solid plate per pitch length} &= \frac{0.9 \times p \times t \times f_u}{\gamma_{mb}} \\ &= \frac{0.9 \times 60 \times 15 \times 410}{1.25 \times 1000} = 265.68 \text{ kN} \end{aligned}$$

Efficiency of bolted joint ( $\eta$ ):  $\frac{\text{Strength of bolted joint}}{\text{Strength of solid plate}} \times 100$

$$\eta = \frac{116.08}{265.68} \times 100 = 43.70\%$$

**Example 6:** Determine the strength and efficiency of the lap joint shown in fig. Bolts are of 20 mm dia and of 4.6 grade. The two plates to be joined are 10 mm and 12 mm thick.

**Solution:**

Say  $d = 20 \text{ mm}$

Table 19, P-73

Dia of hole =  $d_0 = 20 + 2 = 22 \text{ mm}$

$g = 100 \text{ mm}$ ,

$f_u$  of plate = 410 MPa

For 4.6 grade of bolt

$f_u$  of bolt = 400 MPa

**1) Strength of bolt in Single shear per gauge width**

$$V_{dsb} = n \times \left( \frac{f_u}{\sqrt{3}} \right) \times \left( \frac{n_n A_{nb} + n_s A_{sb}}{\pi_{mb}} \right)$$

No of bolts ( $n$ ) = 2.

Assuming Shank is interfering the shear plane

$$n_n = 0 \quad n_s = 1, \gamma_{mb} = 1.25$$

$$A_{sb} = \frac{\pi}{4} (d)^2 = \frac{\pi}{4} (20)^2 = 314.16 \text{ mm}^2,$$

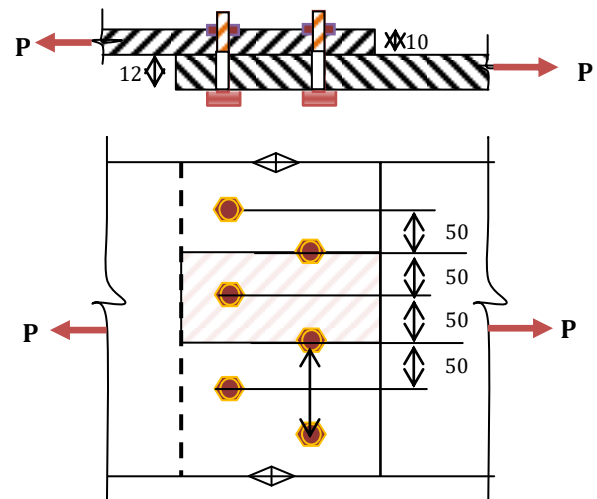



$$V_{dsb} = 2 \times \frac{400}{\sqrt{3}} \times \frac{0 + 1 \times 314.16}{1.25 \times 1000} = 116.08 \text{ kN}$$

## 2) Strength of bolt in Bearing

$$V_{dpb} = n \times \frac{2.5 \times k_b \times d \times t \times f_u}{\gamma_{mb}}$$

$k_b$  is the least of the following:

$$1) \frac{e}{3d_0} = NA \quad 2) \frac{p}{3d_0} - 0.25 = NA \quad 3) \frac{f_{ub}}{f_u} = \frac{400}{410} = 0.98 \quad 4) 1$$

$$V_{dpb} = 2 \times \frac{2.5 \times 0.98 \times 20 \times 10 \times 400}{1.25 \times 1000} = 313.60 \text{ kN}$$

## 3. Strength of plate in tearing:

$$T_{dn} = \frac{0.9(g - nd_0) \times t \times f_u}{\gamma_{m1}} = \frac{0.9 \times (100 - 1 \times 22) \times 10 \times 410}{1.25 \times 1000} = 230.26 \text{ kN}$$

**The strength of bolted joint of plate is the least of  $V_{dsb}$ ,  $V_{dpb}$  and  $T_{dn}$ .**

$\therefore$  The strength of bolted joint = 116.08 kN

$$\text{Strength of solid plate per pitch length} = \frac{0.9 \times p \times t \times f_u}{\gamma_{mb}}$$

$$= \frac{0.9 \times 100 \times 10 \times 410}{1.25 \times 1000} = 295.2 \text{ kN}$$

Efficiency of bolted joint ( $\eta$ ):  $\frac{\text{Strength of bolted joint}}{\text{Strength of solid plate}} \times 100$

$$\eta = \frac{116.08}{295.2} \times 100 = 39.32\%$$

**Example 7.®:** A single bolted double cover butt joint of plates 16 mm thick is made with 22 mm dia bolts at a gauge of 100 mm. find the safe load per gauge length of the joint. Find also the efficiency of the joint.

### Solution:

Dia of bolt  $d = 22 \text{ mm}$

Table 19, P-73

Dia of hole  $= d_0 = 22 + 2 = 24 \text{ mm}$

Gauge length ( $g$ ) = 100 mm

$f_u$  of plate = 410 MPa

Assuming 4.6 grade of bolt

$f_u$  of bolt = 400 MPa

$f_y = 0.6 \times 400 = 240 \text{ MPa}$

Thickness of double cover plate

$$\neq \frac{5}{8} \times t = \frac{5}{8} \times 16 = 10 \text{ mm}$$

Say  $t_c = 12 \text{ mm}$

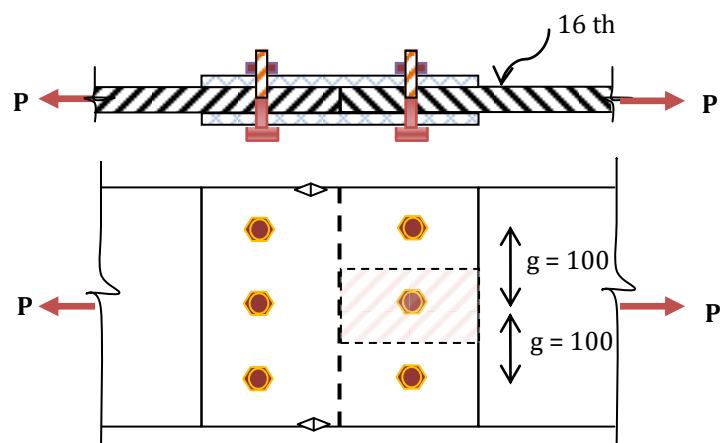



**1) Strength of bolt in double shear per gauge width**

$$V_{dsb} = n \left[ \left( \frac{f_u}{\sqrt{3}} \right) \times \left( \frac{n_n A_{nb} + n_s A_{sb}}{\gamma_{mb}} \right) \right]$$

Assuming both shank and thread interfere the shear plane.

$$n_n = 1, \quad n_s = 1, \quad \gamma_{mb} = 1.25$$

$$A_{sb} = \frac{\pi}{4} d^2 = \frac{\pi}{4} \times 22^2 = 380.13 \text{ mm}^2$$

$$A_{nb} = 0.78 \times \frac{\pi}{4} d^2 = 0.78 \times 380.13 = 296.50 \text{ mm}^2$$

$$V_{dsb} = 1 \times \left[ \frac{400}{\sqrt{3}} \times \left( \frac{1 \times 380.13 + 1 \times 296.50}{1.25 \times 1000} \right) \right] = 125.01 \text{ KN}$$

**2) Strength of bolt in Bearing**

$$V_{dpb} = n \times \left[ \frac{2.5 \times k_b \times d \times t^* \times f_u}{\gamma_{mb}} \right]$$

$t^*$  = Min thickness of a) Thickness of main plate = 16 mm

b) Sum of the thickness of cover plate = 12+12=24 mm

Therefore  $t^* = 16 \text{ mm}$

$k_b$  is the least of the following:

$$1) \frac{e}{3d_0} = NA \quad 2) \frac{p}{3d_0} - 0.25 = NA \quad 3) \frac{f_{ub}}{f_u} = \frac{400}{410} = 0.98 \quad 4) 1$$

$$V_{dpb} = 1 \times \left[ \frac{2.5 \times 0.98 \times 22 \times 16 \times 400}{1.25 \times 1000} \right] = 276 \text{ KN}$$

**3) Strength of plate in tearing per gauge width**

$$T_{dn} = \frac{0.9(g - d_0) \times t \times f_u}{\gamma_{m1}} = \frac{0.9 \times (100 - 24) \times 16 \times 410}{1.25 \times 1000} = 358.96 \text{ KN}$$

The strength of bolted joint per gauge width of plate is the least of  $V_{dsb}$ ,  $V_{dpb}$  and  $T_{dn}$ .

∴ The strength of bolted joint per gauge width = **125.01 KN**

$$\text{Strength of solid plate per gauge length} = \frac{0.9 \times g \times t \times f_u}{\gamma_{mb}}$$

$$= \frac{0.9 \times 100 \times 16 \times 410}{1.25 \times 1000} = 472.32 \text{ KN}$$

$$\text{Efficiency of bolted joint } (\eta) = \frac{\text{Strength of bolted joint per gauge length}}{\text{Strength of solid plate per gauge length}} \times 100$$

$$\eta = \frac{125.01}{472.32} \times 100 = 26.47\%$$



**Example 8:®:** A single bolted double cover butt joint of plates 16 mm thick is made with 3-22 mm dia bolts at a gauge of 100 mm. Find the safe load of the joint. Also, determine the efficiency of the joint.

**Solution:**

Dia of bolt  $d = 22\text{mm}$

Table 19, P-73

Dia of hole  $= d_o = 22 + 2 = 24\text{ mm}$

Gauge length  $= 100\text{ mm}$

$f_u$  of plate  $= 410\text{ MPa}$

Assuming 4.6 grade of bolt

$f_u$  of bolt  $= 400\text{ MPa}$

Thickness of double cover plate

$$\neq \frac{5}{8} \times t = \frac{5}{8} \times 16 = 10\text{mm}$$

Say  $t_c = 12\text{ mm}$

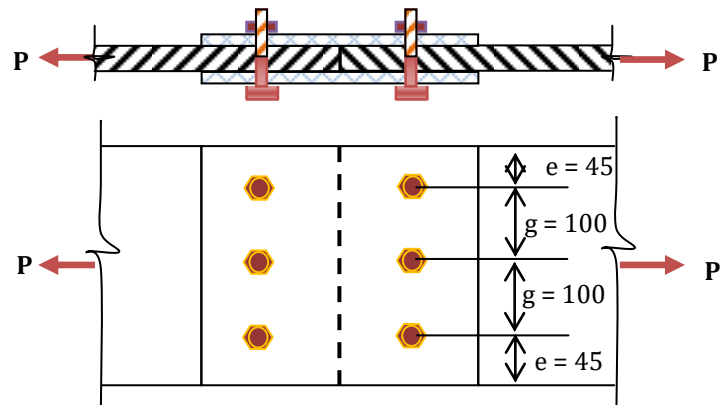

**1) Strength of bolted joint in double shear:**

$$V_{dsb} = N \times \left[ \left( \frac{f_u}{\sqrt{3}} \right) \times \left( \frac{n_n A_{nb} + n_s A_{sb}}{\gamma_{mb}} \right) \right]$$

Assuming both shank and thread interfere the shear plane.

$$n_n = 1, \quad n_s = 1, \quad \gamma_{mb} = 1.25$$

$$A_{sb} = \frac{\pi}{4} d^2 = \frac{\pi}{4} \times 22^2 = 380.13\text{ mm}^2$$

$$A_{nb} = 0.78 \times \frac{\pi}{4} d^2 = 0.78 \times 380.13 = 296.50\text{ mm}^2$$

$$V_{dsb} = 3 \times \left[ \frac{400}{\sqrt{3}} \times \left( \frac{1 \times 380.13 + 1 \times 296.50}{1.25 \times 1000} \right) \right] = 375.03\text{KN}$$

**2) Strength of bolted joint in Bearing:**

$$V_{dpb} = N \times \left[ \frac{2.5 \times k_b \times d \times t^* \times f_u}{\gamma_{mb}} \right]$$

$t^*$  = Min thickness of

a) Thickness of main plate = 16 mm

b) Sum of the thickness of cover plate = 12+12=24 mm

Therefore  $t = 16\text{ mm}$

$k_b$  is the least of the following:

$$1) \frac{e}{3d_o} = \frac{40}{3 \times 24} = 0.56 \quad \text{Edge distance } e = 1.5 \times 24 = 36\text{ mm say } 40\text{ mm}$$

$$2) \frac{p}{3d_o} - 0.25 = \frac{100}{3 \times 24} - 0.25 = 1.14 \quad 3) \frac{f_{ub}}{f_u} = \frac{400}{410} = 0.98 \quad 4) 1$$

$$V_{dpb} = 3 \times \left[ \frac{2.5 \times 0.56 \times 22 \times 16 \times 400}{1.25 \times 1000} \right] = 473.10\text{ KN}$$





**3) Strength of plate in tearing for full width of plate:**

$$b = 2 \times 40 + 2 \times 100 = 280 \text{ mm}$$

$$T_{dn} = \frac{0.9(b - nd_0) \times t \times f_u}{\gamma_{m1}}$$

$$T_{dn} = \frac{0.9 \times (280 - 3 \times 24) \times 16 \times 410}{1.25 \times 1000} = 982.43 \text{ KN}$$

The strength of bolted joint is the least of  $V_{dsb}$ ,  $V_{dpb}$  and  $T_{dn}$ .

∴ The strength of bolted joint = **375.03 KN**

$$\text{Strength of solid plate for full width} = \frac{0.9 \times b \times t \times f_u}{\gamma_{mb}}$$

$$= \frac{0.9 \times 280 \times 16 \times 410}{1.25 \times 1000} = 1322.50 \text{ KN}$$

$$\text{Efficiency of bolted joint } (\eta) = \frac{\text{Strength of bolted joint}}{\text{Strength of solid plate}} \times 100$$

$$\eta = \frac{375.03}{1322.50} \times 100 = 28.36\%$$

**Example 9®:** A double bolted double cover butt joint is used to connect plates of 12 mm thick. Determine the efficiency of the joint.

**Solution:**

Thickness of cover plate

$$\neq \frac{5}{8} \times t = \frac{5}{8} \times 12 = 7.5 \text{ mm}$$

Say 8 mm

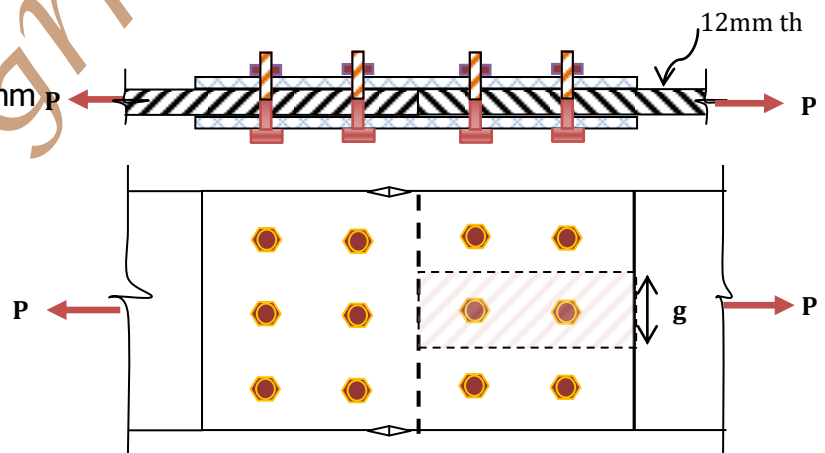

$t^*$  = Min thickness of

a) Thickness of main plate = 12 mm

b) Sum of the thickness of cover plate = 16 mm

Dia of bolt using unwin's formula

$$d = 6.04\sqrt{t^*} = 6.04\sqrt{12} = 20.92 \text{ mm}$$

Say dia of bolt = 20 mm.

Table 19, P-73, Dia of hole =  $d_o = 20 + 2 = 22 \text{ mm}$

Assuming 4.6 grade of bolt,  $f_u$  of bolt = 400 MPa

$f_u$  of plate = 410 MPa

**1) Strength of bolt in double shear per gauge width**

$$V_{dsb} = n \left[ \left( \frac{f_u}{\sqrt{3}} \right) \times \left( \frac{n_n A_{nb} + n_s A_{sb}}{\gamma_{mb}} \right) \right]$$

Assuming both shank and thread interfere the shear plane.



$$n_n = 1, \quad n_s = 1, \quad \gamma_{mb} = 1.25$$

$$A_{sb} = \frac{\pi}{4} d^2 = \frac{\pi}{4} \times 20^2 = 314.16 \text{ mm}^2$$

$$A_{nb} = 0.78 \times \frac{\pi}{4} d^2 = 0.78 \times \frac{\pi}{4} 20^2 = 245.04 \text{ mm}^2$$

$$V_{dsb} = 2 \times \left[ \frac{400}{\sqrt{3}} \times \left( \frac{1 \times 245.04 + 1 \times 314.16}{1.25 \times 1000} \right) \right] = 206.63 \text{ KN}$$

2) **Strength of bolt in Bearing**

$$V_{dpb} = n \times \left[ \frac{2.5 \times k_b \times d \times t^* \times f_u}{\gamma_{mb}} \right]$$

1)  $\frac{e}{3d_0} = \frac{35}{3 \times 22} = 0.53$       Edge distance  $e = 1.5 \times 22 = 33 \text{ mm}$  say 35 mm

Assuming pitch  $\neq$  2.5 dia of bolt  
 $= 2.5 \times 20 = 50 \text{ mm}$ , Say 60 mm

2)  $\frac{p}{3d_0} - 0.25 = \frac{60}{3 \times 22} - 0.25 = 0.66$       3)  $\frac{f_{ub}}{f_u} = \frac{400}{410} = 0.98$       4) 1

$$V_{dpb} = 2 \times \left[ \frac{2.5 \times 0.53 \times 20 \times 12 \times 400}{1.25 \times 1000} \right] = 203.52 \text{ KN}$$

The strength of plate in tearing per gauge width of plate is the least of  $V_{dsb}$  and  $V_{dpb}$

3) **Strength of plate in tearing per gauge width**

$$T_{dn} = \frac{0.9A_n \times f_u}{\gamma_{m1}} = 203.52 \times 10^3 \text{ N}$$

$$T_{dn} = \frac{0.9(g - d_0) \times t \times f_u}{\gamma_{m1}} = \frac{0.9 \times (g - 22) \times 12 \times 410}{1.25} = 203.52 \times 10^3 \text{ N}$$

$$g = \frac{203.52 \times 10^3 \times 1.25}{0.9 \times 12 \times 410} + 22 = 79.45 \text{ mm}$$

Pitch  $\neq$  2.5 dia of bolt =  $2.5 \times 20 = 50 \text{ mm}$

Let the pitch or gauge width = 80 mm.

Strength of plate in tearing per gauge width

$$T_{dn} = \frac{0.9(g - d_0) \times t \times f_u}{\gamma_{m1}} = \frac{0.9 \times (80 - 22) \times 12 \times 410}{1.25 \times 1000} = 205.60 \text{ KN}$$

The strength of bolted joint per gauge width of plate is the least of  $V_{dsb}$ ,  $V_{dpb}$  and  $T_{dn}$ .

$\therefore$  The strength of bolted joint per gauge width = **203.52 KN**

$$\begin{aligned} \text{Strength of solid plate per gauge width} &= \frac{0.9 \times g \times t \times f_u}{\gamma_{mb}} \\ &= \frac{0.9 \times 80 \times 12 \times 410}{1.25 \times 1000} = 283.40 \text{ KN} \end{aligned}$$

$$\text{Efficiency of bolted joint } (\eta) = \frac{\text{Strength of bolted joint per gauge width}}{\text{Strength of solid plate per gauge width}} \times 100$$

$$\eta = \frac{203.52}{283.40} \times 100 = 71.80 \%$$



**Example 10.®:** A double cover butt joint is used to connect two flats 200 ISF 10 with 8 mm cover plates. The two plates are connected by 9 bolts in chain bolting at a pitch of 60 mm, arranged in three rows with three bolts in each row as shown in fig. Determine the strength and efficiency of the joint. The dia of bolt used is 20 mm. Assume grade of bolt as 5.6.

**Solution:**

Size of flat used = 200 ISF 10, width of flat = 200 mm,  
 thickness of flat = 10 mm.  
 Dia of bolt  $d = 20$  mm  
 Table 19, P-73

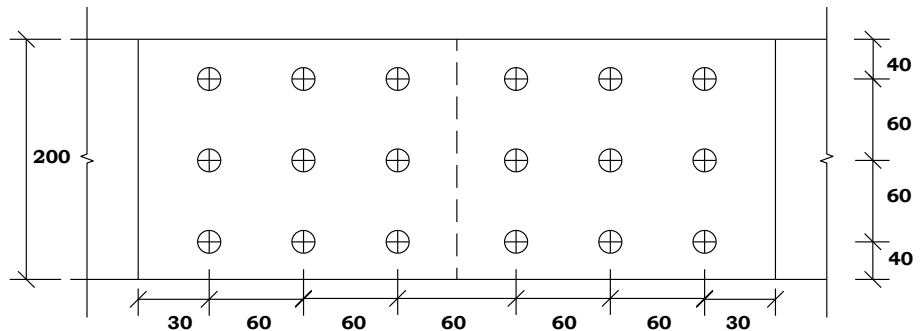

Dia of hole  $= d_o = 20 + 2 = 22$  mm

Pitch = 60 mm

Assuming 5.6 grade of bolt,  $f_u$  of bolt = 500 MPa,  $f_u$  of plate = 410 MPa

Total no of bolts  $N = 9$

**1) Strength of bolted joint in double shear**

$$V_{dsb} = N \left[ \left( \frac{f_u}{\sqrt{3}} \right) \times \left( \frac{n_n A_{nb} + n_s A_{sb}}{\gamma_{mb}} \right) \right]$$

Assuming both shank and thread interfere the shear plane.

$$n_n = 1, \quad n_s = 1, \quad \gamma_{mb} = 1.25$$

$$A_{sb} = \frac{\pi}{4} d^2 = \frac{\pi}{4} \times 20^2 = 314.16 \text{ mm}^2$$

$$A_{nb} = 0.78 \times \frac{\pi}{4} d^2 = 0.78 \times \frac{\pi}{4} 20^2 = 245.04 \text{ mm}^2$$

$$V_{dsb} = 9 \times \left[ \frac{500}{\sqrt{3}} \times \left( \frac{1 \times 245.04 + 1 \times 314.16}{1.25 \times 1000} \right) \right] = 1162.61 \text{ KN}$$

**2) Strength of bolt in Bearing**

$$V_{dpb} = N \times \left[ \frac{2.5 \times k_b \times d \times t^* \times f_u}{\gamma_{mb}} \right]$$

$t^*$  = Min thickness of a) Thickness of main plate = 10 mm

b) Sum of the thickness of cover plate = 8 + 8 = 16 mm

Therefore  $t = 10$  mm

$k_b$  is the least of the following:

$$1) \frac{e}{3d_0} = \frac{40}{3 \times 22} = 0.61 \quad 2) \frac{p}{3d_0} - 0.25 = \frac{60}{3 \times 22} - 0.25 = 0.66$$

$$3) \frac{f_{ub}}{f_u} = \frac{500}{410} = 1.22 \quad 4) 1$$



$$V_{dpb} = 9 \times \left[ \frac{2.5 \times 0.61 \times 20 \times 10 \times 500}{1.25 \times 1000} \right] = 1098 \text{ KN}$$

**3) Strength of plate in tearing**

$$T_{dn} = \frac{0.9A_n \times t \times f_u}{\gamma_{m1}}$$

$$T_{dn} = \frac{0.9(b - nd_0) \times t \times f_u}{\gamma_{m1}} = \frac{0.9 \times (200 - 3 \times 22) \times 10 \times 410}{1.25 \times 1000} = 395.60 \text{ KN}$$

The strength of bolted joint is the least of  $V_{dsb}$ ,  $V_{dpb}$  and  $T_{dn}$ .

∴ The strength of bolted joint = **395.60 KN**

$$\begin{aligned} \text{Strength of solid plate for full width of plate} &= \frac{0.9 \times b \times t \times f_u}{\gamma_{mb}} \\ &= \frac{0.9 \times 200 \times 10 \times 410}{1.25 \times 1000} = 590.4 \text{ KN} \end{aligned}$$

Efficiency of bolted joint ( $\eta$ ):  $\frac{\text{Strength of bolted joint}}{\text{Strength of solid plate}} \times 100$

$$\eta = \frac{395.60}{590.4} \times 100 = 67\%$$

**Example 11:®** A double cover butt joint is used to connect two flats of 10 mm with 8 mm cover plates. The two plates are connected by chain bolting at a pitch of 60 mm, arranged in three rows with 20 mm dia bolts. Determine the strength and efficiency of the joint. Assume grade of bolt as 4.6.

**Solution:**

Thickness of flat = 10 mm.

Dia of bolt  $d = 20 \text{ mm}$

Table 19, P-73, Dia of hole =  $d_0$   
=  $20 + 2 = 22 \text{ mm}$

Pitch = 60 mm

Assuming 4.6 grade of bolt

$f_u$  of bolt = 400 MPa

$f_u$  of plate = 410 MPa

Total no of bolts per pitch width

( $n$ ) = 3

**1) Strength of bolt in double shear:**

$$V_{dsb} = n \left[ \left( \frac{f_u}{\sqrt{3}} \right) \times \left( \frac{n_n A_{nb} + n_s A_{sb}}{\gamma_{mb}} \right) \right]$$

Assuming both shank and thread interfere the shear plane.

$$n_n = 1, \quad n_s = 1, \quad \gamma_{mb} = 1.25 \quad A_{sb} = \frac{\pi}{4} d^2 = \frac{\pi}{4} \times 20^2 = 314.16 \text{ mm}^2$$

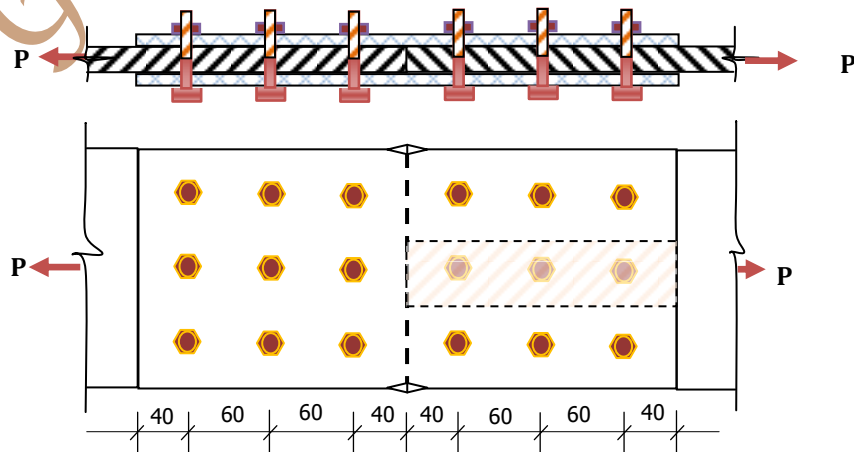



$$A_{nb} = 0.78 \times \frac{\pi}{4} d^2 = 0.78 \times \frac{\pi}{4} 20^2 = 245.04 \text{ mm}^2$$

$$V_{dsb} = 3 \times \left[ \frac{400}{\sqrt{3}} \times \left( \frac{1 \times 245.20 + 1 \times 314.16}{1.25 \times 1000} \right) \right] = 310.03 \text{ KN}$$

2) **Strength of bolt in Bearing**

$$V_{dpb} = n \times \left[ \frac{2.5 \times k_b \times d \times t^* \times f_u}{\gamma_{mb}} \right]$$

- $t^*$  = Min thickness of
- a) Thickness of main plate = 10 mm
  - b) Sum of the thickness of cover plate = 8 + 8 = 16 mm

Therefore  $t = 10 \text{ mm}$

$k_b$  is the least of the following:

- 1)  $\frac{e}{3d_0} = \frac{40}{3 \times 22} = 0.61$     2)  $\frac{p}{3d_0} - 0.25 = \frac{60}{3 \times 22} - 0.25 = 0.66$     3)  $\frac{f_{ub}}{f_u} = \frac{400}{410} = 0.98$   
 4) 1

$$V_{dpb} = 3 \times \left[ \frac{2.5 \times 0.61 \times 20 \times 10 \times 400}{1.25 \times 1000} \right] = 292.8 \text{ KN}$$

3) **Strength of plate in tearing per pitch**

$$T_{dn} = \frac{0.9(p - nd_0) \times t \times f_u}{\gamma_{m1}} = \frac{0.9 \times (60 - 1 \times 22) \times 10 \times 410}{1.25 \times 1000} = 112.18 \text{ KN}$$

The strength of bolted joint per gauge width of plate is the least of  $V_{dsb}$ ,  $V_{dpb}$  and  $T_{dn}$ .

∴ The strength of bolted joint per gauge width = 112.18KN

$$\begin{aligned} \text{Strength of solid plate per pitch length} &= \frac{0.9 \times p \times t \times f_u}{\gamma_{mb}} \\ &= \frac{0.9 \times 60 \times 10 \times 410}{1.25 \times 1000} = 177.12 \text{ KN} \end{aligned}$$

$$\text{Efficiency of bolted joint } (\eta) = \frac{\text{Strength of bolted joint per pitch length}}{\text{Strength of solid plate per pitch length}} \times 100$$

$$\eta = \frac{112.18}{177.12} \times 100 = 63.34\%$$

**Example 12:®** A double cover butt joint is used to connect two flats 200 ISF 10. The two plates are connected by 9 bolts by chain bolting system at a pitch of 60 mm and edge distance of 40 mm arranged in three rows with three bolts in each row. Determine the strength and efficiency of the joint using HSFG bolts of 8.8 grade. The surfaces are not treated.

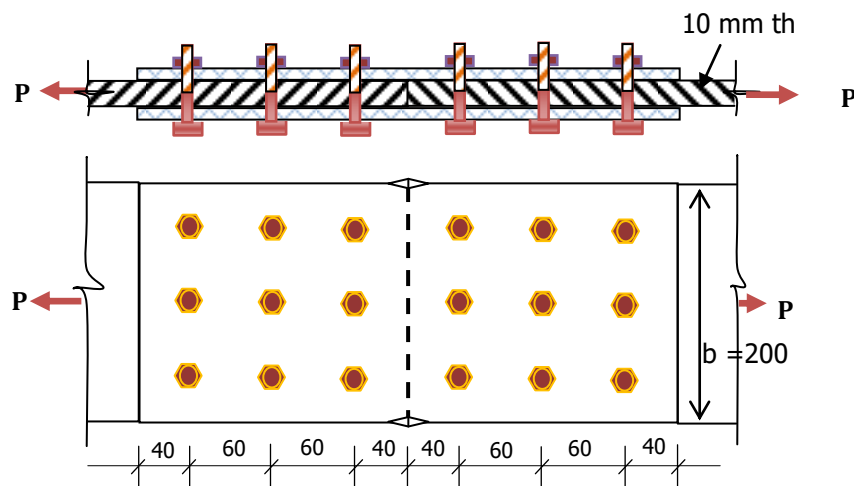



**Solution:**

Thickness of cover plate  $\neq \frac{5}{8} \times t = \frac{5}{8} \times 10 = 6.25 \text{ mm}$  Say 8 mm

$t^*$  = Min thickness of

- a) Thickness of main plate = 10 mm
  - b) Sum of the thickness of cover plate = 8 + 8 = 16 mm
- Dia of bolt using unwin's formula

$$d = 6.04\sqrt{t} = 6.04\sqrt{10} = 19.01 \text{ mm}$$

Say Dia of bolt  $d = 18 \text{ mm}$

Table 19, P-73, Dia of hole =  $d_o = 18 + 2 = 20 \text{ mm}$

Pitch = 60 mm, HSFG bolts of 8.8 grade,  $f_u$  of bolt = 800 MPa

$f_u$  of plate = 410 MPa

**1) Strength of bolt in double shear: P-76, Cl: 10.4**

$$V_{dsf} = N \times \frac{V_{nsf}}{\gamma_{mf}} = N \times \frac{\mu_f n_e k_h F_o}{\gamma_{mf}}$$

No of bolts  $N = 9$ ,  $\mu_f = 0.20$ , P- 77, table 20,  $n_e = 2$  (Double shear),  $k_h = 1$   
 Proof Load  $F_o = A_{nb} \times f_o$

$$A_{nb} = \text{Area of thread} = 0.78 \times \frac{\pi \times d^2}{4} = 0.78 \times \frac{\pi \times 18^2}{4} = 198.49 \text{ mm}^2$$

$$\text{Proof Stress } f_o = 0.7 f_{ub} = 0.7 \times 800 = 560 \text{ N/mm}^2$$

$$\text{Proof Load } F_o = A_{nb} \times f_o = 198.49 \times 560 = 111.15 \times 10^3 \text{ N}$$

$$V_{dsf} = 9 \times \frac{0.20 \times 2 \times 1 \times 111.15 \times 10^3}{1.1 \times 1000} = 363.76 \text{ kN}$$

**2) Strength of bolt in Bearing**

$$V_{dpb} = N \times \left[ \frac{2.5 \times k_b \times d \times t^* \times f_u}{\gamma_{mb}} \right]$$

$k_b$  is the least of the following:

$$1) \frac{e}{3d_o} = \frac{40}{3 \times 20} = 0.67 \quad 2) \frac{p}{3d_o} - 0.25 = \frac{60}{3 \times 20} - 0.25 = 0.75$$

$$3) \frac{f_{ub}}{f_u} = \frac{800}{410} = 1.95 \quad 4) 1$$

$$V_{dpb} = 9 \times \left[ \frac{2.5 \times 0.67 \times 18 \times 10 \times 800}{1.25 \times 1000} \right] = 1736.64 \text{ KN}$$

**3) Strength of plate in tearing**

$$T_{dn} = \frac{0.9(b - nd_o) \times t \times f_u}{\gamma_{m1}} = \frac{0.9 \times (200 - 3 \times 20) \times 10 \times 410}{1.25 \times 1000} = 413.28 \text{ KN}$$

The strength of bolted joint : Is the least of  $V_{dsb}$ ,  $V_{dpb}$  and  $T_{dn}$ .

$\therefore$  The strength of bolted joint = 363.76KN



$$\text{Strength of solid plate for full length} = \frac{0.9 \times b \times t \times f_u}{\gamma_{mb}}$$

$$= \frac{0.9 \times 200 \times 10 \times 410}{1.25 \times 1000} = 590.40 \text{ KN}$$

$$\text{Efficiency of bolted joint } (\eta) = \frac{\text{Strength of bolted joint}}{\text{Strength of solid plate}} \times 100$$

$$\eta = \frac{363.76}{590.40} \times 100 = 61.61 \%$$

**Example 13:@** Four members OA, OB, OC and OD are to be connected at a joint "O" to a 10 mm thick gusset plate. Details of the members and the loads carried by them are shown in fig. If the connection to the gusset plate be made with 18 mm dia bolts, find the number of bolts required to connect each member to the gusset plate. Sketch the joint details.

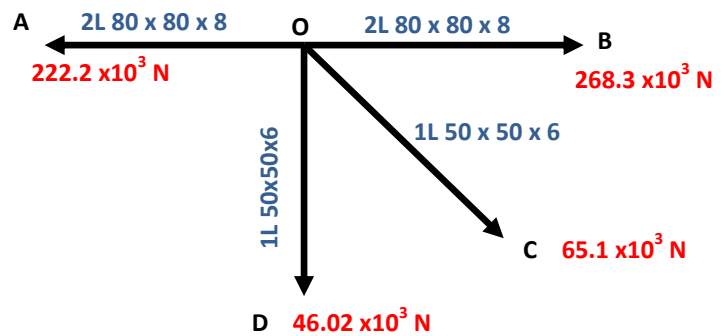

**Solution:**

Dia of bolt = 18 mm

Thickness of gusset plate = 10 mm

Members OA and OB are designed as Discontinuous Members

**a) Member OA : 2- ISA 80 x 80 x 8 mm**

Force in the member =  $222.2 \times 10^3 \text{ N} = 222.2 \text{ KN}$

**1) Strength of one bolt double shear**

$$V_{dsb} = \left[ \left( \frac{f_u}{\sqrt{3}} \right) \times \left( \frac{n_n A_{nb} + n_s A_{sb}}{\gamma_{mb}} \right) \right]$$

$n_n = 1, n_s = 1 \therefore$  Shank and tread interfere the shear plane.

$$\gamma_{mb} = 1.25$$

$$A_{sb} = \frac{\pi}{4} d^2 = \frac{\pi}{4} 18^2 = 254.50 \text{ mm}^2$$

$$A_{nb} = 0.78 \times \frac{\pi}{4} d^2 = 0.78 \times \frac{\pi}{4} 18^2 = 198.50 \text{ mm}^2$$

$$V_{dsb} = \left[ \frac{400}{\sqrt{3}} \times \left( \frac{1 \times 198.50 + 1 \times 254.50}{1.25 \times 1000} \right) \right] = 83.64 \text{ KN}$$

**2) Strength of one bolt in Bearing**

$$V_{dpb} = \left[ \frac{2.5 \times k_b \times d \times t^* \times f_u}{\gamma_{mb}} \right]$$

$t^*$  = Min thickness of

a) Thickness of gusset plate = 10 mm





b) Sum of the thickness of angles = 8 + 8 = 16mm

Therefore  $t = 10 \text{ mm}$

$k_b$  is the least of the following:

1)  $\frac{e}{3d_0} = \frac{40}{3 \times 20} = 0.66$  Edge distance  $e = 1.5 \times 20 = 30 \text{ mm}$  say 40 mm

Assuming Pitch  $\neq 2.5$  dia of bolt =  $2.5 \times 18 = 45 \text{ mm}$ , say 60 mm

2)  $\frac{p}{3d_0} - 0.25 = \frac{60}{3 \times 20} - 0.25 = 0.75$     3)  $\frac{f_{ub}}{f_u} = \frac{400}{410} = 0.98$     4) 1

$$V_{d_{pb}} = \left[ \frac{2.5 \times 0.66 \times 18 \times 10 \times 400}{1.25 \times 1000} \right] = 95.04 \text{ KN}$$

Bolt value (BV) = Least of  $V_{dsb}$ ,  $V_{d_{pb}}$ .

Bolt value (BV) = 83.64 kN.

$$\text{No of bolts} = \frac{\text{Force}}{\text{Bolt value}} = \frac{222.2}{83.64} = 2.66 \text{ Say 03 No's}$$

**b) Member OB : 2- ISA 80 x 80 x 8 mm**

Force in the member =  $268.3 \times 10^3 \text{ N} = 268.3 \text{ KN}$

$V_{dsb} = 83.64 \text{ KN}$ ,

$V_{d_{pb}} = 95.04 \text{ KN}$

Bolt value (BV) = 83.64 kN.

$$\text{No of Bolts} = \frac{\text{Force}}{\text{Bolt Value}} = \frac{268.3}{83.64} = 3.21 \text{ Say 4}$$

**c) Member OC: 1- ISA 50 x 50 x 6 mm**

Force in the member =  $65.1 \times 10^3 \text{ N} = 65.1 \text{ KN}$

**1) Strength of one bolt in Single shear**

$$V_{dsb} = \left[ \left( \frac{f_u}{\sqrt{3}} \right) \times \left( \frac{n_n A_{nb} + n_s A_{sb}}{\gamma_{mb}} \right) \right]$$

Assuming Shank is interfering the shear plane.

$$n_s = 1, \quad \gamma_{mb} = 1.25$$

$$A_{sb} = \frac{\pi}{4} d^2 = \frac{\pi}{4} 18^2 = 254.50 \text{ mm}^2$$

$$V_{dsb} = \left[ \frac{400}{\sqrt{3}} \times \left( \frac{1 \times 254.50}{1.25 \times 1000} \right) \right] = 47.01 \text{ KN}$$

**2) Strength of one bolt in Bearing**

$$V_{d_{pb}} = \left[ \frac{2.5 \times k_b \times d \times t^* \times f_u}{\gamma_{mb}} \right]$$

- $t^*$  = Min thickness of
- a) Thickness of gusset plate = 10 mm
  - b) Thickness of angle = 6mm



Therefore  $t = 6 \text{ mm}$

$k_b$  is the least of the following:

1)  $\frac{e}{3d_0} = \frac{40}{3 \times 20} = 0.66$  Edge distance  $e = 1.5 \times 20 = 30 \text{ mm}$  say  $40 \text{ mm}$

Assuming Pitch  $\neq 2.5 \text{ dia of bolt} = 2.5 \times 18 = 45 \text{ mm}$ , say  $60 \text{ mm}$

2)  $\frac{p}{3d_0} - 0.25 = \frac{60}{3 \times 20} - 0.25 = 0.75$     3)  $\frac{f_{ub}}{f_u} = \frac{400}{410} = 0.98$     4) 1

$V_{dpb} = \left[ \frac{2.5 \times 0.66 \times 18 \times 6 \times 400}{1.25 \times 1000} \right] = 57.02 \text{ KN}$

Bolt value (BV) = Least of  $V_{dsb}$ ,  $V_{dpb}$ .

Bolt value (BV) =  $47.01 \text{ kN}$ .

No of bolts =  $\frac{\text{Force}}{\text{Bolt value}} = \frac{65.10}{47.01} = 1.38$  Say 02 No's

**D) Member OD : 1- ISA 50 x 50 x 6 mm**

Force in the member =  $46.02 \times 10^3 \text{ N} = 46.02 \text{ KN}$

$V_{dsb} = 47.01 \text{ KN}$ ,

$V_{dpb} = 57.02 \text{ KN}$

Bolt value (BV) =  $47.01 \text{ kN}$ .

No of bolts =  $\frac{\text{Force}}{\text{Bolt value}} = \frac{46.02}{47.01} = 0.98$  Say 02 No's

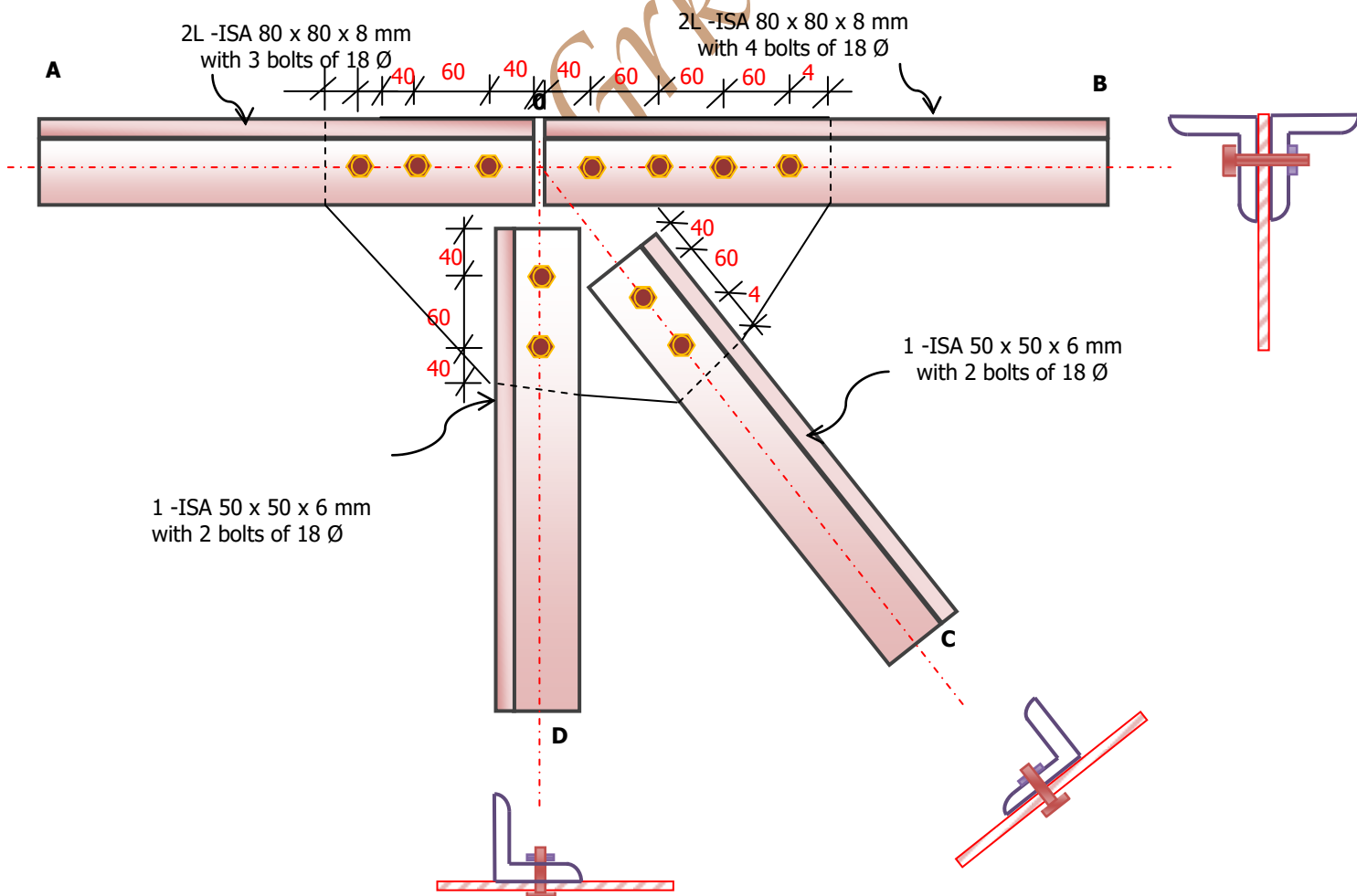



**Example 14:** Figure shows a joint in the lower chord of a roof truss. Design the bolted connection using HSFG bolts of grade 8.8.

Draw the sketch showing the details of joint.

**Solution:**

Assuming thickness of gusset plate = 10 mm.

Dia of bolt using Unwin's formula  $d' = 6.04\sqrt{t} = 6.04 \times \sqrt{8} = 17.10 \text{ mm}$

Say dia of bolt = 16 mm.

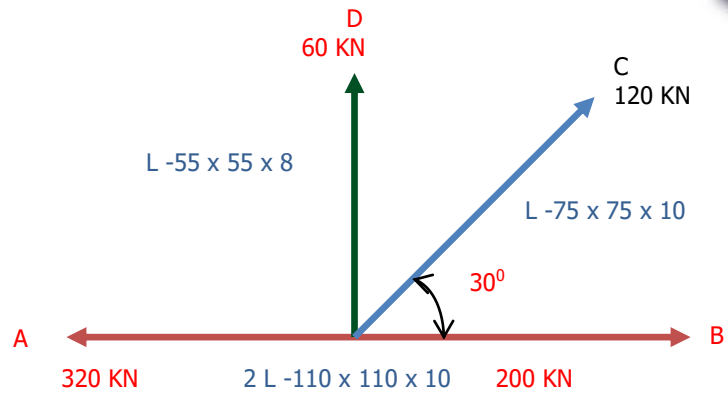

**Members OA and OB are designed as a single continuous Member AB**

**a) Member AB: 2-ISA 110 x 110 x 10 mm**

Net Force in the member = 320 – 200 = 120 kN

**1) Strength of bolt in double shear: P-76, Cl: 10.4**

$$V_{dsf} = \frac{V_{nsf}}{\gamma_{mf}} = \frac{\mu_f n_e k_h F_o}{\gamma_{mf}}$$

$\mu_f = 0.55$ ,  $n_e = 2$  (Double shear),  $k_h = 1$

Proof Load  $F_o = A_{nb} \times f_o$

$$A_{nb} = \text{Area of thread} = 0.78 \times \frac{\pi \times d^2}{4} = 0.78 \times \frac{\pi \times 16^2}{4} = 156.83 \text{ mm}^2$$

$$\text{Proof Stress } f_o = 0.7 f_{ub} = 0.7 \times 800 = 560 \text{ N/mm}^2$$

$$\text{Proof Load } F_o = A_{nb} \times f_o = 156.83 \times 560 = 87.82 \times 10^3 \text{ N}$$

$$V_{dsf} = \frac{0.55 \times 2 \times 1 \times 87.82 \times 10^3}{1.1 \times 1000} = 87.82 \text{ kN}$$

**2) Strength of bolt in Bearing**

$$V_{dpb} = \left[ \frac{2.5 \times k_b \times d \times t^* \times f_u}{\gamma_{mb}} \right]$$

$t^*$  = Min thickness of a) Thickness of gusset plate = 10 mm

b) Sum of the thickness of angles = 10 + 10 = 20 mm

Therefore  $t = 10 \text{ mm}$

$k_b$  is the least of the following:

1)  $\frac{e}{3d_0} = \frac{30}{3 \times 18} = 0.56$  Edge distance  $e = 1.5 \times 18 = 27 \text{ mm}$  say 30 mm

Assuming Pitch  $\neq 2.5$  dia of bolt =  $2.5 \times 20 = 50 \text{ mm}$ , say 60 mm

2)  $\frac{p}{3d_0} - 0.25 = \frac{60}{3 \times 18} - 0.25 = 0.86$  3)  $\frac{f_{ub}}{f_u} = \frac{800}{410} = 1.95$  4) 1



$$V_{dpb} = \left[ \frac{2.5 \times 0.56 \times 16 \times 10 \times 800}{1.25 \times 1000} \right] = 143.36 \text{ KN}$$

Bolt value (BV) = Least of  $V_{dsb}$ ,  $V_{dpb}$ .

Bolt value (BV) = 87.82 kN.

$$\text{No of bolts} = \frac{\text{Force}}{\text{Bolt value}} = \frac{120}{87.82} = 1.36 \quad \text{Say 02 No's}$$

**b) Design of Members OC and OD:**

Strength of the bolt is calculated for 8 mm th angle (conservative side)

**1) Strength of one bolt in single shear: P-76, Cl: 10.4**

$$V_{dsf} = \frac{V_{nsf}}{\gamma_{mf}} = \frac{\mu_f n_e k_h F_o}{\gamma_{mf}}$$

$\mu_f = 0.55$ ,  $n_e = 1$  (Single shear),  $k_h = 1$

Proof Load  $F_o = A_{nb} \times f_o$

$$A_{nb} = \text{Area of thread} = 0.78 \times \frac{\pi \times d^2}{4} = 0.78 \times \frac{\pi \times 16^2}{4} = 156.83 \text{ mm}^2$$

$$\text{Proof Stress } f_o = 0.7 f_{ub} = 0.7 \times 800 = 560 \text{ N/mm}^2$$

$$\text{Proof Load } F_o = A_{nb} \times f_o = 156.83 \times 560 = 87.82 \times 10^3 \text{ N}$$

$$V_{dsf} = \frac{0.55 \times 1 \times 1 \times 87.82 \times 10^3}{1.1 \times 1000} = 43.91 \text{ kN}$$

**2) Strength of one bolt in Bearing**

$$V_{dpb} = \left[ \frac{2.5 \times k_b \times d \times t^* \times f_u}{\gamma_{mb}} \right]$$

$t^*$  = Min thickness of a) Thickness of gusset plate = 10 mm

b) Thickness of angle = 8 mm

Therefore  $t = 8 \text{ mm}$

$k_b$  is the least of the following:

$$1) \frac{e}{3d_0} = \frac{30}{3 \times 18} = 0.56 \quad \text{Edge distance } e = 1.5 \times 18 = 27 \text{ mm say } 30 \text{ mm}$$

Assuming Pitch  $\neq 2.5 \text{ dia of bolt} = 2.5 \times 20 = 50 \text{ mm, say } 60 \text{ mm}$

$$2) \frac{p}{3d_0} - 0.25 = \frac{60}{3 \times 18} - 0.25 = 0.86 \quad 3) \frac{f_{ub}}{f_u} = \frac{800}{410} = 1.95 \quad 4) 1$$

$$V_{dpb} = \left[ \frac{2.5 \times 0.56 \times 16 \times 8 \times 800}{1.25 \times 1000} \right] = 114.69 \text{ KN}$$

Bolt value (BV) = Least of  $V_{dsb}$ ,  $V_{dpb}$ .

Bolt value (BV) = 43.91kN.

$$\text{No of bolts in member OC} = \frac{\text{Force}}{\text{Bolt value}} = \frac{120}{43.91} = 2.73 \quad \text{Say 03 No's}$$

$$\text{No of bolts in member OD} = \frac{\text{Force}}{\text{Bolt value}} = \frac{60}{43.91} = 1.37 \quad \text{Say 02 No's}$$

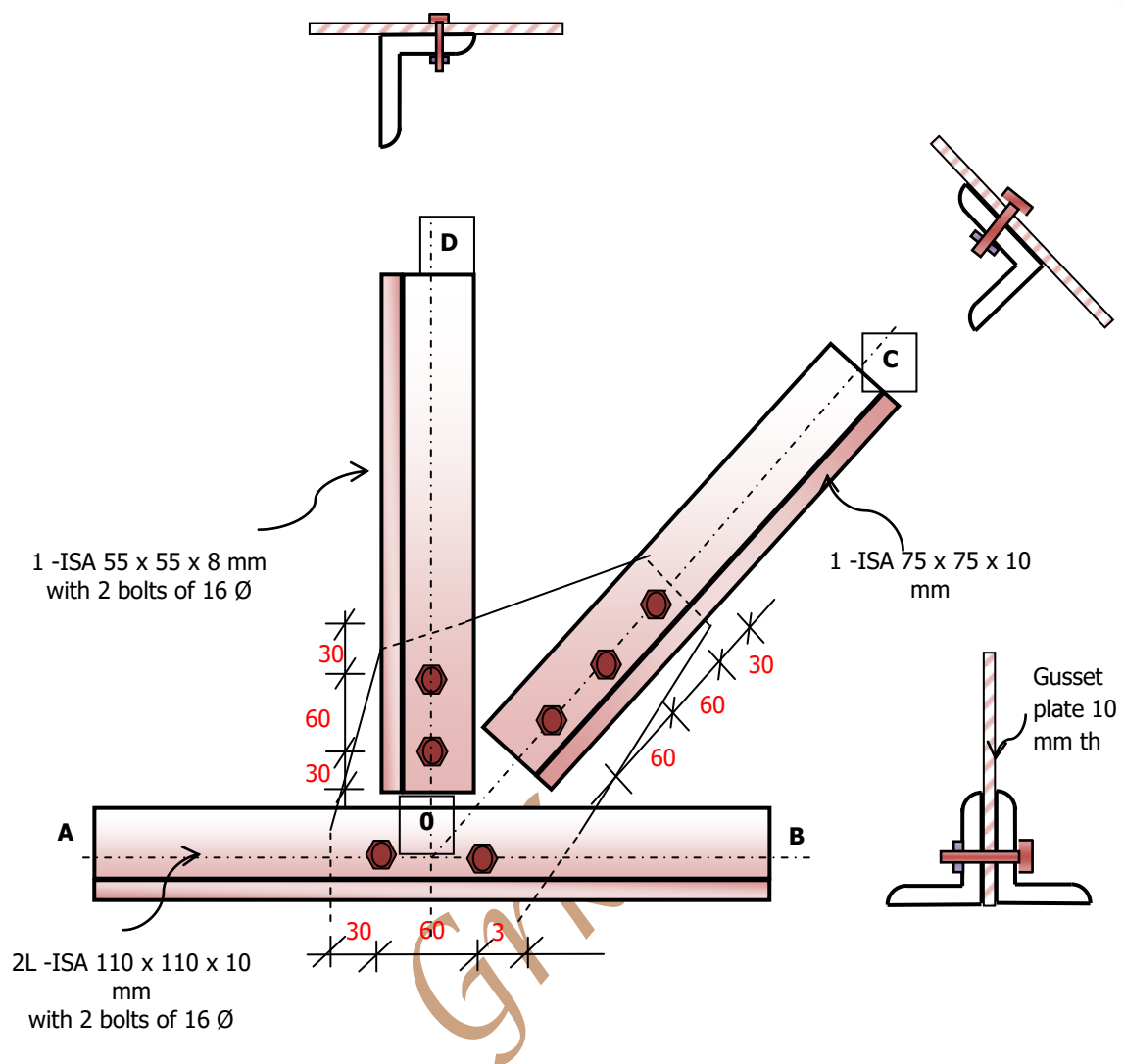

**Example 15:** A truss of a bridge diagonal consists of 16 mm thick flat and carries a pull of 750 kN connected to a gusset plate by a double cover butt joint. The thickness of each cover plate is 8 mm. Determine the number of bolts required and width of the flat. Use HSFG bolts of 10.8 grade. The surfaces are blasted with shot or grit and spray metalized with zinc. Also determine the efficiency of the joint by i) Chain bolting system, ii) Diamond bolting system.

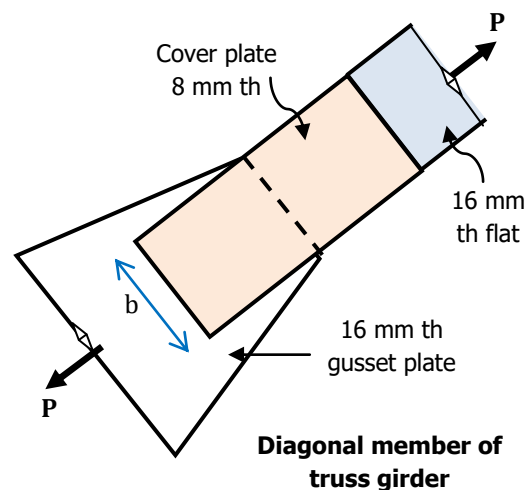

**Solution:**

Pull  $P = 750 \text{ kN}$

Dia of bolt using unwin's formula

$$d = 6.04\sqrt{t} = 6.04 \times \sqrt{16} = 24.16 \text{ mm}$$

Say dia of bolt = 22 mm.

Dia of hole  $d_0 = 22 + 2 = 24 \text{ mm}$



**1) Strength of one bolt in single shear: P-76, Cl: 10.4**

$$V_{dsf} = \frac{V_{nsf}}{\gamma_{mf}} = \frac{\mu_f n_e k_h F_o}{\gamma_{mf}}$$

$\mu_f = 0.25$ , Table – 20, P-77,  $n_e = 2$  (Double shear),  $k_h = 1$   
 Proof Load  $F_o = A_{nb} \times f_o$

$$A_{nb} = \text{Area of thread} = 0.78 \times \frac{\pi \times d^2}{4} = 0.78 \times \frac{\pi \times 22^2}{4} = 296.50 \text{ mm}^2$$

$$\text{Proof Stress } f_o = 0.7 f_{ub} = 0.7 \times 1000 = 700 \text{ N/mm}^2$$

$$\text{Proof Load } F_o = A_{nb} \times f_o = 296.50 \times 700 = 207.55 \times 10^3 \text{ N}$$

$$V_{dsf} = \frac{0.25 \times 2 \times 1 \times 207.55 \times 10^3}{1.1 \times 1000} = 94.34 \text{ kN}$$

**2) Strength of one bolt in Bearing**

$$V_{dpb} = \left[ \frac{2.5 \times k_b \times d \times t^* \times f_u}{\gamma_{mb}} \right]$$

$t^*$  = Min thickness of  
 a) Thickness of main plate = 16 mm  
 b) Sum of the thickness of cover plate = 8 + 8 = 16 mm

Therefore  $t = 16 \text{ mm}$

$k_b$  is the least of the following:

$$1) \frac{e}{3d_o} = \frac{40}{3 \times 24} = 0.56 \quad \text{Edge distance } e = 1.5 \times 24 = 36 \text{ mm say } 40 \text{ mm}$$

Assuming Pitch  $\neq 2.5$  dia of bolt =  $2.5 \times 22 = 55 \text{ mm}$ , say 60 mm

$$2) \frac{p}{3d_o} - 0.25 = \frac{60}{3 \times 24} - 0.25 = 0.58 \quad 3) \frac{f_{ub}}{f_u} = \frac{1000}{410} = 2.44 \quad 4) 1$$

$$V_{dpb} = \left[ \frac{2.5 \times 0.56 \times 22 \times 16 \times 1000}{1.25 \times 1000} \right] = 394.24 \text{ kN}$$

Bolt value (BV) = Least of  $V_{dsf}$ ,  $V_{dpb}$ .

Bolt value (BV) = **94.34kN.**

No of bolts =

$$\frac{\text{Force}}{\text{Bolt value}} = \frac{750}{94.34} = 7.95 \text{ say } 9$$

No's

**Case 1: Chain Bolting:**

Width of flat =  $2 \times 40 + 2 \times 60 = 200 \text{ mm}$

Strength of bolted joint in double shear =  $9 \times 94.34 = 849.06 \text{ kN}$

Strength of bolted joint in bearing =  $9 \times 394.34 = 3549.06 \text{ kN}$

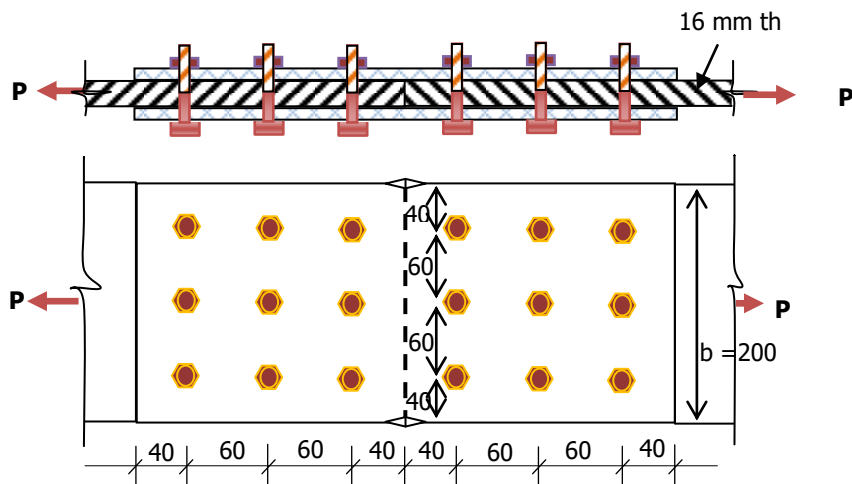



**Strength of plate in tearing:**

$$T_{dn} = \frac{0.9A_n \times t \times f_u}{\gamma_{m1}} = \frac{0.9(b - nd_0) \times t \times f_u}{\gamma_{m1}}$$

$$T_{dn} = \frac{0.9 \times (200 - 3 \times 24) \times 16 \times 410}{1.25 \times 1000} = 604.57 \text{ KN}$$

**The strength of bolted joint of plate is the least of  $V_{dsb}$ ,  $V_{dpb}$  and  $T_{dn}$ .**

$\therefore$  The strength of bolted joint = **604.57 KN**

$$\text{Strength of solid plate} = \frac{0.9 \times b \times t \times f_u}{\gamma_{mb}}$$

$$= \frac{0.9 \times 200 \times 16 \times 410}{1.25 \times 1000} = 944.64 \text{ KN}$$

$$\text{Efficiency of bolted joint } (\eta) = \frac{\text{Strength of bolted joint}}{\text{Strength of solid plate}} \times 100$$

$$\eta = \frac{604.57}{944.64} \times 100 = 64 \%$$

**Case 2: DiamondBolting system:**

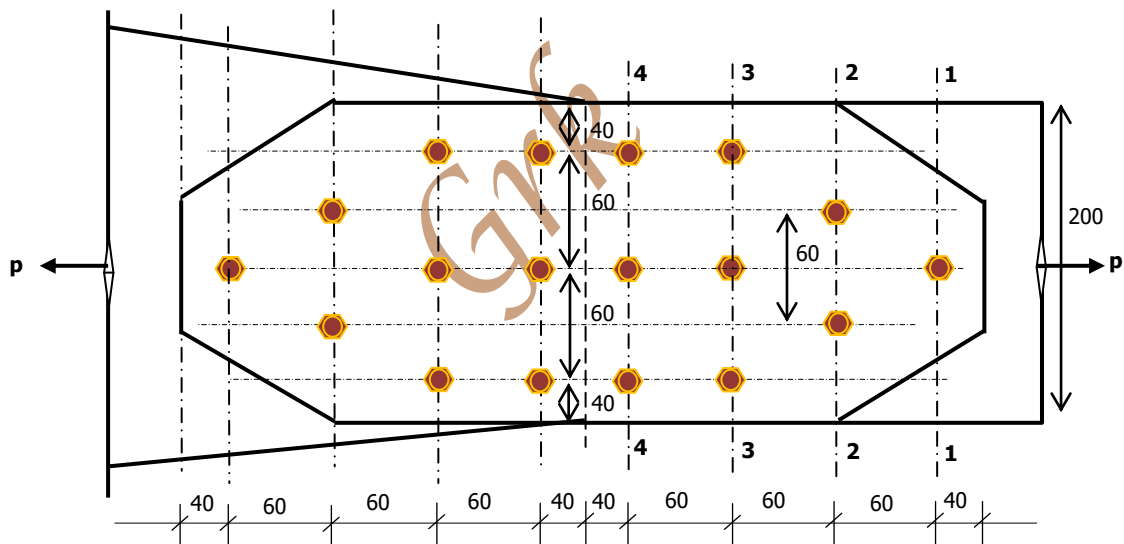

Width of flat =  $2 \times 40 + 2 \times 60 = 200 \text{ mm}$

Strength of bolted joint in double shear =  $9 \times 94.34 = 849.06 \text{ kN}$

Strength of bolted joint in bearing =  $9 \times 394.34 = 3549.06 \text{ kN}$

**Strength of plate in tearing:**

$$T_{dn} = \frac{0.9A_n \times t \times f_u}{\gamma_{m1}} = \frac{0.9(b - nd_0) \times t \times f_u}{\gamma_{m1}}$$

**Strength of plate in tearing at section 1-1:**

$$\frac{0.9 \times (200 - 1 \times 24) \times 16 \times 410}{1.25 \times 1000} = 831.28 \text{ kN}$$



**Strength of plate in tearing at section 2 – 2:**

$$T_{dn} = \frac{0.9(b - nd_0) \times t \times f_u}{\gamma_{m1}} + \text{No of bolts before section 2} - 2 \times BV$$

$$T_{dn} = \frac{0.9 \times (200 - 2 \times 24) \times 16 \times 410}{1.25 \times 1000} + 1 \times 94.34 = 812.27 \text{ kN}$$

**Strength of plate in tearing at section 3 – 3:**

$$T_{dn} = \frac{0.9(b - nd_0) \times t \times f_u}{\gamma_{m1}} + \text{No of bolts before section 3} - 3 \times BV$$

$$T_{dn} = \frac{0.9 \times (200 - 3 \times 24) \times 16 \times 410}{1.25 \times 1000} + 3 \times 94.34 = 887.59 \text{ kN}$$

**Strength of plate in tearing at section 4 – 4:**

$$T_{dn} = \frac{0.9(b - nd_0) \times t \times f_u}{\gamma_{m1}} + \text{No of bolts before section 4} - 4 \times BV$$

$$T_{dn} = \frac{0.9 \times (200 - 3 \times 24) \times 16 \times 410}{1.25 \times 1000} + 6 \times 94.34 = 1170.61 \text{ kN}$$

**The strength of bolted joint of plate is the least of  $V_{dsb}$ ,  $V_{dps}$  and  $T_{dn}$ .**

$\therefore$  The strength of bolted joint = **812.27 kN**

$$\text{Strength of solid plate} = \frac{0.9 \times b \times t \times f_u}{\gamma_{mb}}$$

$$= \frac{0.9 \times 200 \times 16 \times 410}{1.25 \times 1000} = 944.64 \text{ kN}$$

$$\text{Efficiency of bolted joint } (\eta) = \frac{\text{Strength of bolted joint}}{\text{Strength of solid plate}} \times 100$$

$$\eta = \frac{812.27}{944.64} \times 100 = 86 \%$$

**Example 16:®**

Find the maximum load which can be transferred through the double cover butt joint shown in fig. Find the efficiency of the joint. Use 20 mm dia common bolts.

**Solution:**

Assuming 4.6 grade bolt  
dia of bolt = 20 mm.

Dia of hole  $d_0 = 20 + 2 = 22$   
mm

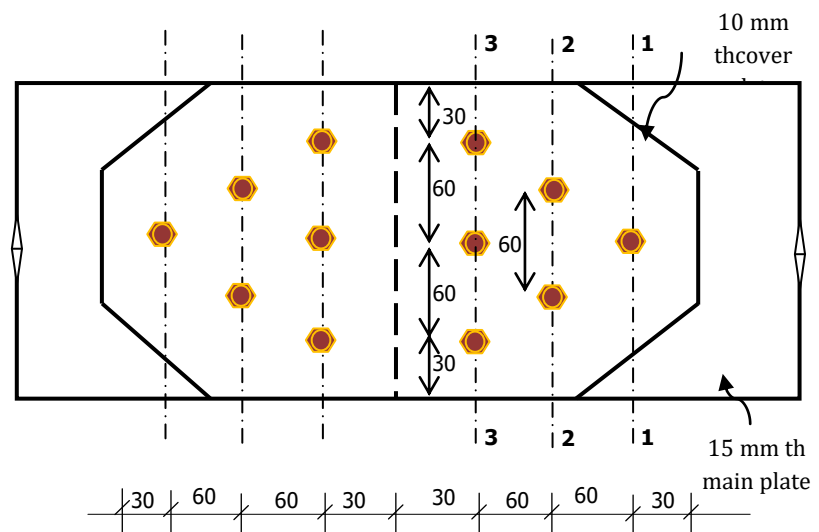



**1) Strength of one bolt in double shear**

$$V_{dsb} = \left[ \left( \frac{f_u}{\sqrt{3}} \right) \times \left( \frac{n_n A_{nb} + n_s A_{sb}}{\gamma_{mb}} \right) \right]$$

Assuming both shank and thread interfere the shear plane.

$$n_n = 1, \quad n_s = 1, \quad \gamma_{mb} = 1.25$$

$$A_{sb} = \frac{\pi}{4} d^2 = \frac{\pi}{4} \times 20^2 = 314.16 \text{ mm}^2$$

$$A_{nb} = 0.78 \times \frac{\pi}{4} d^2 = 0.78 \times \frac{\pi}{4} 20^2 = 245.04 \text{ mm}^2$$

$$V_{dsb} = \left[ \frac{400}{\sqrt{3}} \times \left( \frac{1 \times 245.04 + 1 \times 314.16}{1.25 \times 1000} \right) \right] = 103.31 \text{ KN}$$

**2) Strength of one bolt in Bearing**

$$V_{dpb} = \left[ \frac{2.5 \times k_b \times d \times t^* \times f_u}{\gamma_{mb}} \right]$$

t\* = Min thickness of a) Thickness of main plate = 15 mm

b) Sum of the thickness of cover plate = 10 + 10 = 20 mm

Therefore t = 15 mm

k<sub>b</sub> is the least of the following:

$$1) \frac{e}{3d_0} = \frac{30}{3 \times 22} = 0.45 \quad 2) \frac{p}{3d_0} - 0.25 = \frac{60}{3 \times 22} - 0.25 = 0.66 \quad 3) \frac{f_{ub}}{f_u} = \frac{400}{410} = 0.98$$

4) 1

$$V_{dpb} = \left[ \frac{2.5 \times 0.45 \times 20 \times 15 \times 400}{1.25 \times 1000} \right] = 108 \text{ KN}$$

Bolt value (BV) = Least of V<sub>dsb</sub>, V<sub>dpb</sub>.

Bolt value (BV) = **103.31kN**.

No of bolts = 6 (given)

Strength of bolted joint in double shear = 6 x 103.31 = 619.86kN

Strength of bolted joint in bearing = 6 x 108 = 648 kN

Width of flat = 2 x 30 + 2 x 60 = 180 mm

**Strength of plate in tearing:**

$$T_{dn} = \frac{0.9 A_n \times t \times f_u}{\gamma_{m1}} = \frac{0.9(b - nd_0) \times t \times f_u}{\gamma_{m1}}$$

Strength of plate in tearing at section 1-1:

$$\frac{0.9 \times (180 - 1 \times 22) \times 15 \times 410}{1.25 \times 1000} = 699.62 \text{ kN}$$

Strength of plate in tearing at section 2 - 2:

$$T_{dn} = \frac{0.9(b - nd_0) \times t \times f_u}{\gamma_{m1}} + \text{No of bolts before section 2} - 2 \times \text{BV}$$



$$T_{dn} = \frac{0.9 \times (180 - 2 \times 22) \times 15 \times 410}{1.25 \times 1000} + 1 \times 103.31 = 705.52 \text{ kN}$$

Strength of plate in tearing at section 3 – 3:

$$T_{dn} = \frac{0.9(b - nd_0) \times t \times f_u}{\gamma_{m1}} + \text{No of bolts before section 3} - 3 \times BV$$

$$T_{dn} = \frac{0.9 \times (180 - 3 \times 22) \times 15 \times 410}{1.25 \times 1000} + 3 \times 103.31 = 814.72 \text{ kN}$$

**The strength of bolted joint of plate is the least of  $V_{dsb}$ ,  $V_{dpb}$  and  $T_{dn}$ .**

$\therefore$  The strength of bolted joint = **619.86 kN**

$$\begin{aligned} \text{Strength of solid plate} &= \frac{0.9 \times b \times t \times f_u}{\gamma_{mb}} \\ &= \frac{0.9 \times 180 \times 15 \times 410}{1.25 \times 1000} = 798.04 \text{ kN} \end{aligned}$$

$$\text{Efficiency of bolted joint } (\eta) = \frac{\text{Strength of bolted joint}}{\text{Strength of solid plate}} \times 100$$

$$\eta = \frac{619.86}{798.04} \times 100 = 77.77 \%$$

**Problem:**

Two ISF sections 200 mm x 10 mm each and 1.5m long are to be jointed to make a member length of 3.0m. Design a butt joint with the bolts arranged in a diamond pattern. The flats are supposed to carry a factored tensile force of 450 kN. Steel is of grade Fe 410. 20 mm diameter bolts of grade 5.6 are used to make the connections. Also, determine the efficiency of the joint.

**Problem:**

Two ISF sections 200 mm x 10 mm each and 1.5m long are to be jointed to make a member length of 3.0m. Design a butt joint with the bolts arranged in a diamond pattern. The flats are supposed to carry a factored tensile force of 450 kN. Adopt HSFG bolts of property class 8.8. Also, determine the efficiency of the joint.



**WELDED CONNECTIONS:** *Introduction, Welding process, Welding electrodes, Advantages of Welding, Types and Properties of Welds, Types of joints, Weld symbols, Weld specifications, Effective areas of welds, Design of welds, Simple joints, Moment resistant connections, Continuous Beam to Column connections, Continuous Beam to Beam connections, Beam Column splices, Tubular connections*

6 Hours

**Introduction:**

- Welded connections are direct and efficient means of transferring forces from one member to the adjacent member. Welded connections are generally made by melting base metal from parts to be joined with weld metal, which upon cooling form the connections. A properly welded joint is stronger than the base metal



- Welds may be loaded in shear, tension, compression, or a combination of above.
- Capacities for welds are given in the AISC Specification Section J2 (2005)
- The strength of a weld is dependent on multiple factors, including: base metal, filler metal, type of weld, throat and weld size.

Weld types define the configuration of the weld and its underlying design approach

- Fillet welds and groove welds are most common
- Groove welds fall into two categories
  - ❖ Full penetration – the entire member cross-section is welded
  - ❖ Partial penetration – just part of the member cross-section is welded



**Fillet Weld:**

- ✚ The most commonly used weld is the fillet weld
- ✚ Fillet welds are theoretically triangular in cross-section
- ✚ Fillet welds join two surfaces at approximately right angles to each other in lap, tee, and corner joints

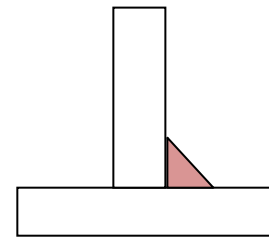

Fillet

**The merits of the fillet welds are:**

- No prior edge preparation is necessary.
- Simple, fast and economical to make, and
- Does not require very skilled labour.

**The demerits of fillet welds are:**

- Not appropriate to transfer forces large in magnitude,
- Poorer performance under fatigue loading, and
- Less attractive in appearance.

**GROOVE WELD:**

Butt welds, as shown in Fig, are made by butting plate surfaces against one another and filling the gap between contact surfaces with weld metal, in the process fusing the base metal also together. In order to ensure full penetration of the weld metal, normally the contact surfaces are cambered to obtain gap for the weld metal to flow easily.

**The merits of butt welds are :**

- Easily designed and fabricated to be as strong as the member.
- Better fatigue characteristics, compared to fillet welds.
- Better appearance, compared to fillet welds, and
- Easy to detail and the length of the connection is considerably reduced.

**The demerits of the butt welds are:**

- More expensive than fillet welds because of the edge preparation required, and
- Require more skilled manpower, than that required for fillet welds.
- Groove welds are specified when a fillet weld is not appropriate for the job
  - ✚ The configuration of the pieces may not permit fillet welding
  - ✚ A strength greater than that provided by a fillet weld is required

Groove welds are made in the space or groove between the two pieces being welded.

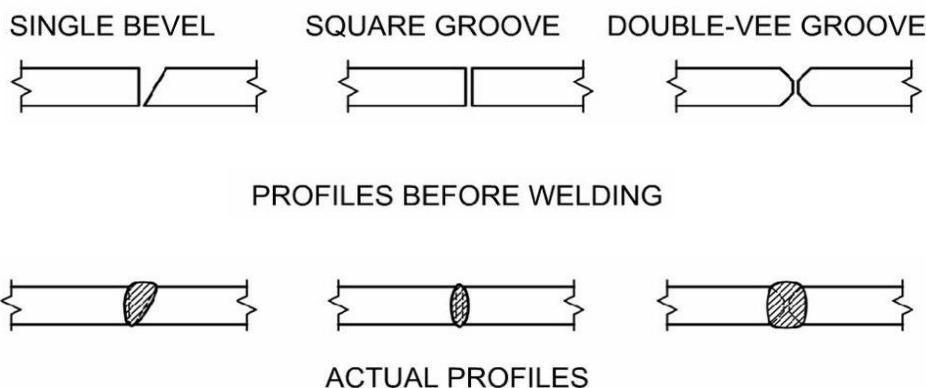



**Full Penetration Groove Weld:**

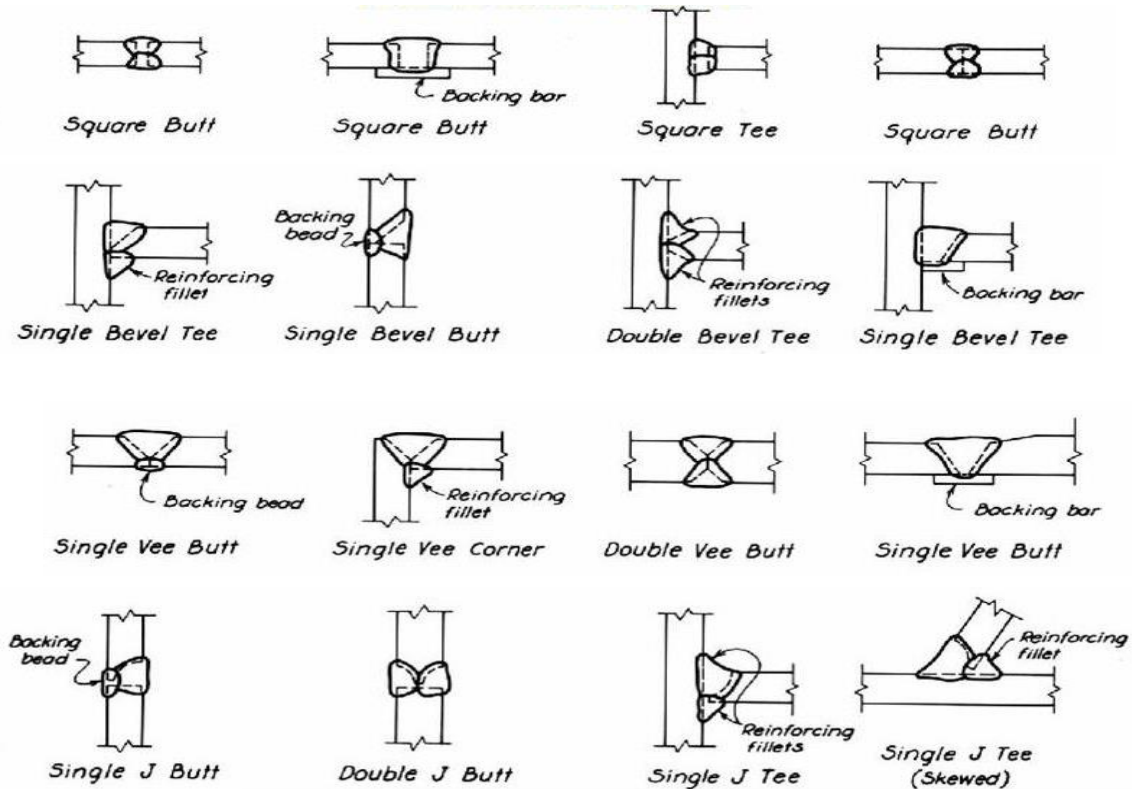

- The bevel or "J" preparation extends over most of or the entire face of the material being joined
- Complete fusion takes place

In some types of full penetration groove welds the material will be beveled from one side of the plate with a separate plate on the opposite side – called backing or a backing bar

**Partial Penetration Groove Weld:** Partial joint penetration welds are used when it is not necessary for the strength of the joint to develop the full cross section of the members being joined.

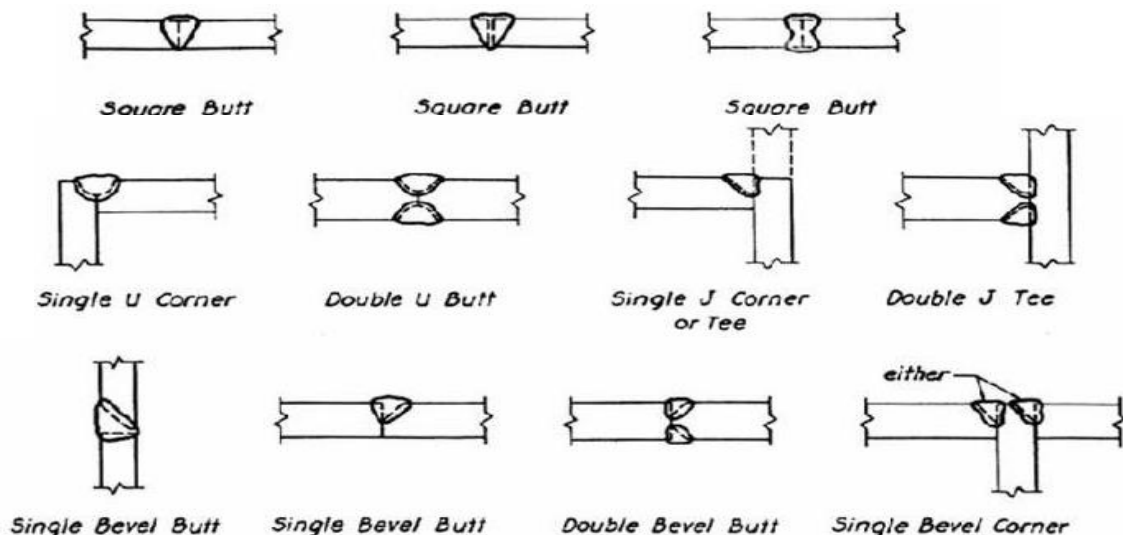



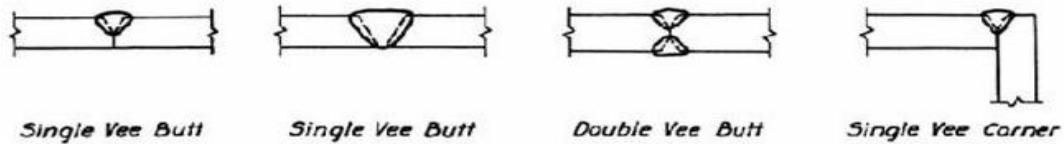

**We**

**Understanding terminology:**

**Tack weld:** A temporary weld used to hold parts in place while more extensive, final welds are made.

**Stitch weld:** A series of welds of a specified length that are spaced a specified distances from each other.

**Continuous weld:** A weld extends continuously from one end of a joint to the other.

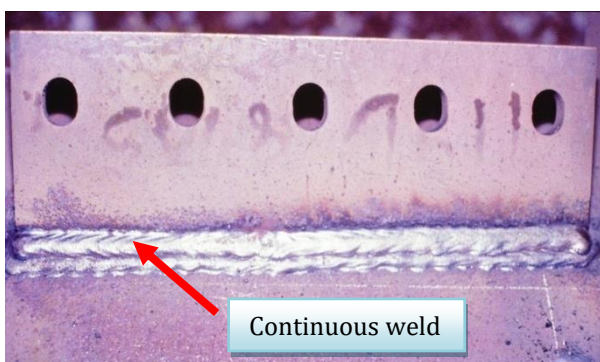
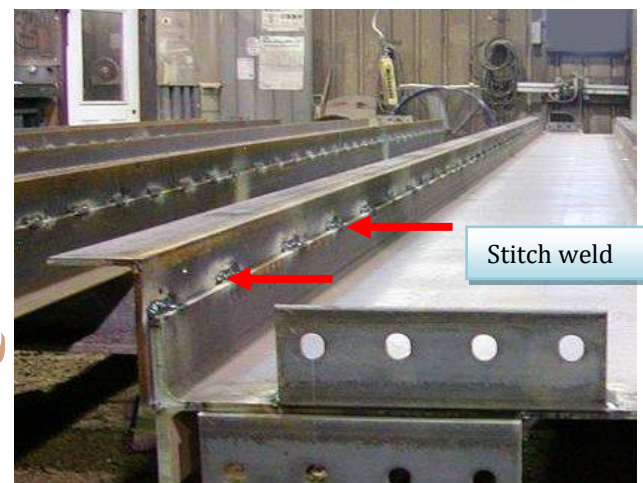
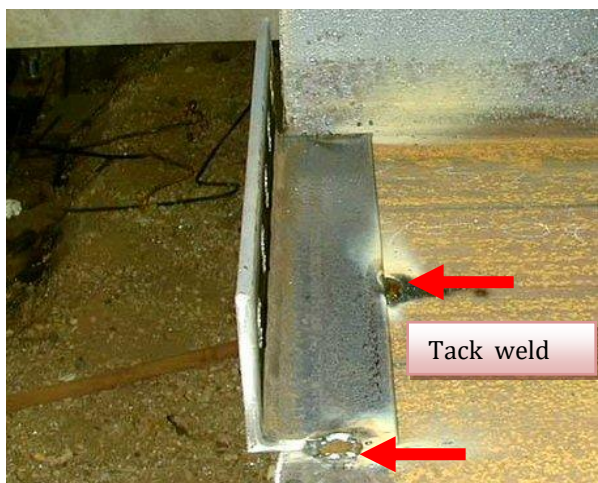

### ADVANTAGES OF WELDED JOINTS

- (i) As no holes are required for welding, the structural members are more effective in taking load.
- (ii) The overall weight of structural steel required is reduced by the use of welded joints.
- (iii) Welded joints are often economical as less labour and material are required for a joint.
- (iv) The welded connections look better than the usually bulky riveted joints.
- (v) The speed of fabrication is higher with the welding process.
- (vi) Any shape of joint can be made with ease.





- (vii) The welding process requires less working space than the riveting process.
- (viii) Complete rigid joints can be provided with the welding process.
- (ix) No noise is produced in the welding process as in the riveting process.

**DISADVANTAGES OF WELDED JOINTS**

- (i) Skilled labour and electricity are required for welding.
- (ii) Internal stresses and warping are produced due to uneven heating and cooling.
- (iii) Welded joints are more brittle and therefore their fatigue strength is less than the members joined.
- (iv) Defects like internal air pockets, slag inclusion and incomplete penetration are difficult to detect.

**P- 78, CI 10.5.3.1**

**Effective throat thickness:** The effective throat thickness of a fillet weld is the perpendicular distance from the root to the hypotenuse of the largest isosceles right – angled triangle that can be inscribed within the weld cross – section as shown in fig.

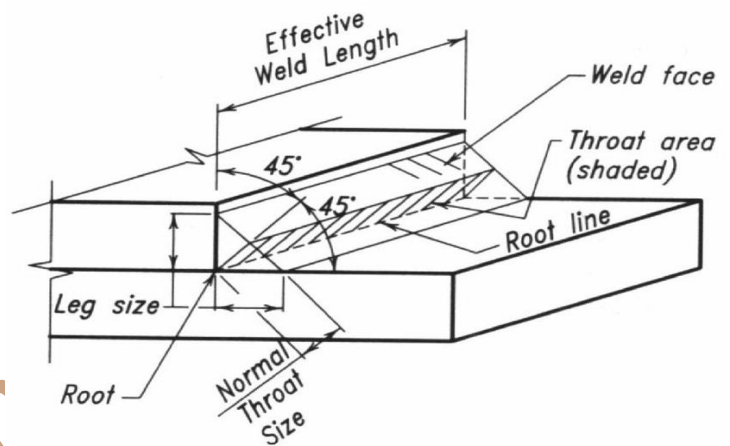

Consider triangle ABC

$$\sin 45^\circ = \frac{AB}{AC}$$

$$AB(t) = AC \times \sin 45^\circ$$

$$t = 0.707 \times D$$

Throat thickness is equal to 0.707 times Size of weld.  $\nless 3 \text{ mm}$

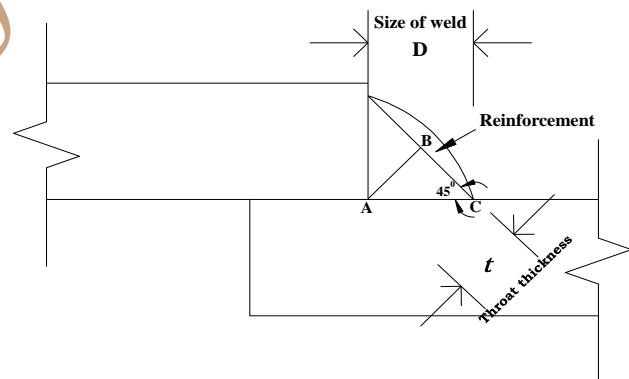

**P- 78, CI 10.5.4.1**

**Effective length:** The effective length of fillet weld shall be taken as only that length specified size and required throat thickness. In practice the actual length of weld is made equal to the effective length shown on the drawing plus twice the weld size, but not less than four times the size of the weld.

**P- 79 ,CI 10.5.7.1**

**Strength of weld:** The strength of the fillet weld is taken equal to the resistance offered by it against shear. It is so, because it is weak in shear as compared to other modes of failure.

Strength of weld = Throat Area x Allowable Shear stress in the weld

Strength of weld = Throat thickness x Length x Allowable Shear stress in the weld



Strength of weld =  $0.707 \times D \times L \times f_{wd}$

$$f_{wd} = \frac{f_{wn}}{\gamma_{mw}}$$

$$f_{wn} = \frac{f_u}{\sqrt{3}} \quad \text{Where, } f_u = \text{Smaller of the ultimate stress of the weld or of the parent metal and}$$

$\gamma_{mw}$  = Partial safety factor ( Table 5, P - 30)

$\gamma_{mw} = 1.25$  for Shop weld

$\gamma_{mw} = 1.5$  for Field weld

$f_u$  = ultimate stress of weld =  $410 \text{ N/mm}^2$

**For shop weld**

$$f_{wd} = \frac{f_u}{\sqrt{3}\gamma_{mw}} = \frac{410}{\sqrt{3} \times 1.25} = 189.37 \text{ N/mm}^2$$

**For Field weld**

$$f_{wd} = \frac{f_u}{\sqrt{3}\gamma_{mw}} = \frac{410}{\sqrt{3} \times 1.50} = 157.81 \text{ N/mm}^2$$

Strength of weld =  $K \times D \times L \times f_{wd}$

**CI : 10.5.3.2**

For the purpose of stress calculation in fillet welds joining face inclined to each other, the effective throat thickness shall be taken as 'K' times fillet size, where, 'K' is a constant, depending upon the angle between fusion faces, as given in Table 22

<b>Angle Between Fusion Faces</b>	$60^\circ - 90^\circ$	$91^\circ - 100^\circ$	$101^\circ - 106^\circ$	$107^\circ - 113^\circ$	$114^\circ - 120^\circ$
<b>Constant 'K'</b>	0.70	0.65	0.60	0.55	0.50

**Design of fillet weld.** Following specifications as per IS: 816-1956 shall be observed in the design of fillet welds.

- The size of a weld must match the size specified on the drawings
- Some welds may meet the required size after a single pass of the welder
- Larger weld sizes may require multiple passes to meet the size requirement
- Common single pass welds include fillet welds up to and including 5/16 inch and thin plate butt welds with no preparation
- Common multiple pass welds include single bevel full penetration groove welds, single bevel partial penetration groove welds, and fillet welds over 5/16 inch



**1. Size of weld :**

**Minimum size:**

The minimum size of the single fillet weld for different plate thickness will be as given in Table 21 P-78, Cl : 10.5.2.3

**MINIMUM SIZE OF FILLET WELD**

<i>Thickness of thicker part</i>	<i>Minimum size</i>
Up to and including 10 mm.	3.0 mm.
Over 10 mm. upto and including 20 mm.	5.0 mm.
Over 20 mm. upto and including 32 mm.	6.0 mm.
Over 32 mm. upto and including 50 mm.	8 mm of first run 10 for minimum size of weld.

**Maximum size (cl: 10.5.8.1):** Maximum size of fillet weld applied to a square edge should not exceed thickness of the edge minus 1.5 mm.

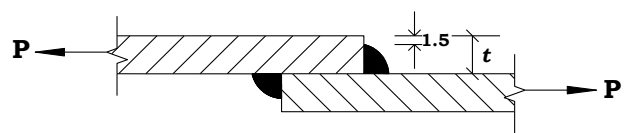

**(cl: 10.5.8.2)**

Maximum size of fillet weld applied to rounded toe of rolled steel section should not exceed  $\frac{3}{4}$  x the thickness of the rounded toe.

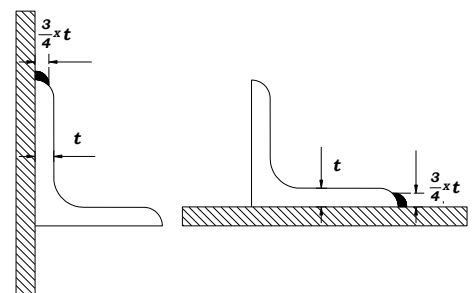

**1. Overlap length: (cl: 10.5.1.2):-**

For lap joint as shown in Fig. the overlap should not be less than four times the thickness of the thinner part joined or 40 mm, whichever is more.

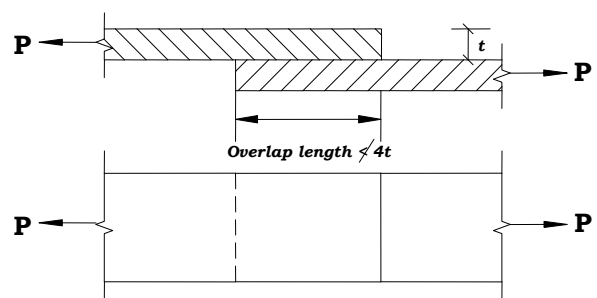

i.e., **Overlap length:** It the Max of the following

- a) 4t, b) 40 mm.

**2. Longitudinal Weld/ Side Weld**

**(cl: 10.5.1.2) :-**

If longitudinal fillet or side fillet welds are used alone in the end connections, the length of each fillet weld should not be less than the perpendicular distance between them as shown in Fig.

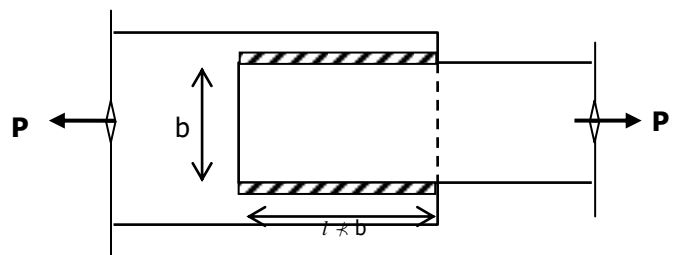



**Transverse Spacing between longitudinal weld:**

The transverse spacing of longitudinal or side fillet welds shall not exceed 16 times the thickness of the thinner part connected, unless an end transverse weld or intermediate plug or slot welds are used to prevent buckling or separation of the parts. This has been shown in Fig.

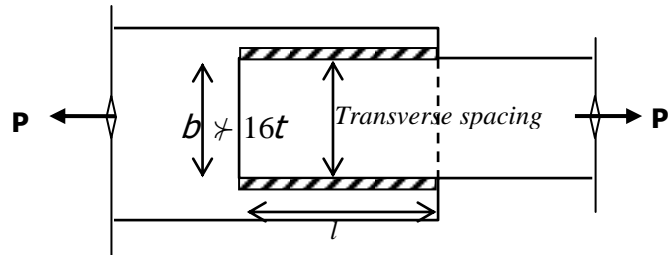

**Note:**

If  $b < 16t$ , only longitudinal weld can be provided

If  $b > 16t$ , along with longitudinal weld End weld should also be provided.

**End Return weld (cl: 10.5.1.1):-**

Fillet welds terminating at ends or sides of parts or members should preferably be returned continuously around the corners for a distance not less than twice the weld size as has been shown in Fig.

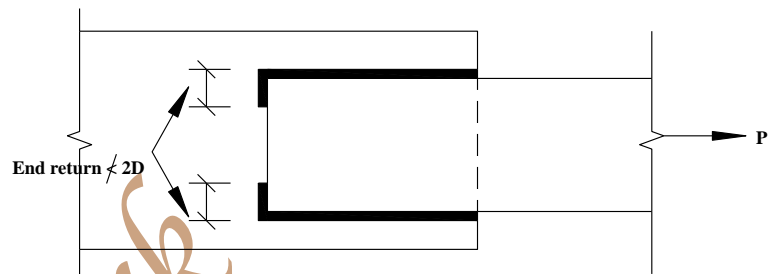

A Single fillet weld should not be subjected to a bending moment about the longitudinal axis of the fillet as shown in Fig. (cl: 10.5.1.3).

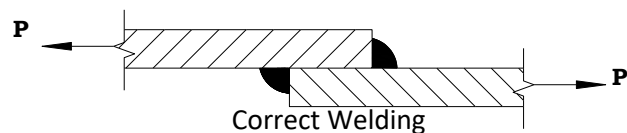
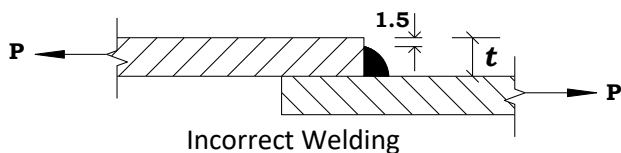

**Problem:®**

Design a 6mm size fillet weld for the lap joint shown in the figure. Assume site weld. Fe 410 steel. Assume width of plate = 100 mm.

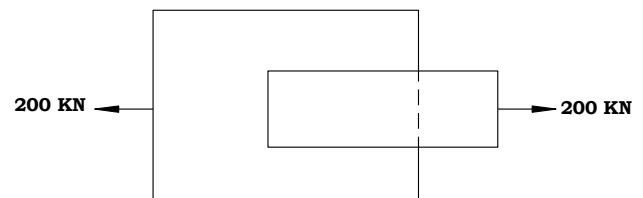

**Solution:**

$$\text{Strength of weld} = 0.707 \times D \times l \times f_{wd}$$

$$f_{wd} = \frac{f_u}{\sqrt{3} \gamma_{mw}}$$

$$\text{Strength of weld} = 0.707 \times 6 \times l \times \frac{410}{\sqrt{3} \times 1.5} = 669.43 l - N$$

In equilibrium,  
Strength of weld = Applied force



$$669.43 l = 200 \text{ kN} = 200 \times 10^3 \text{ N}$$

$$l = \frac{200 \times 1000}{669.43} = 298.76 \text{ mm} \quad \text{Say } 300 \text{ mm}$$

Length of longitudinal weld on each side

$$= \frac{300}{2} = 150 \text{ mm}$$

**Length of longitudinal weld required:**

It is the maximum of the following

1. Overlap length a) 4t b) 40 mm
2. Width of plate (100 mm)
3. Length of longitudinal weld calculated = 150 mm

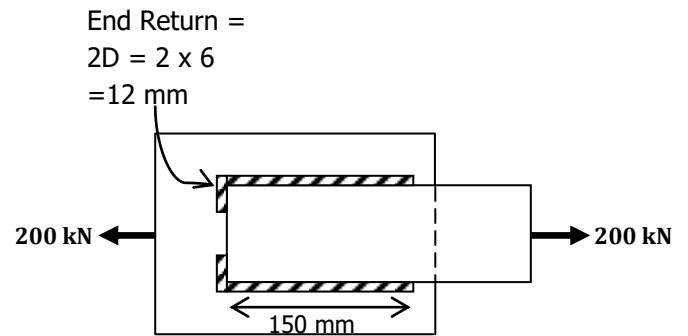

**The overall length of weld provided with end return of  $(2 \times D) = 2 \times 150 + 2 \times 2 \times 6 = 324 \text{ mm}$**

**Problem:®**

Design a suitable fillet weld to connect a tie bar 60 X 8mm to a 12mm thick gusset plate. Assume shop welds. Use Fe 410 steel.

**Solution:**

**Cl: 6.2, P- 32**

Tension capacity of the member/Strength of tie bar =  $T_{dg} = \frac{A_g f_y}{\gamma_{mo}}$

$$T_{dg} = \frac{60 \times 8 \times 250}{1.1} = 109.10 \times 10^3 \text{ N}$$

**Size of weld: P-78, Table 21**

Minimum size of weld for 8mm th plate = 3mm

Maximum size of weld =  $8 - 1.5 = 6.5 \text{ mm}$ . Say 6 mm

$$\text{Strength of weld} = 0.707 \times 6 \times l \times \frac{410}{\sqrt{3} \times 1.25} = 803.31 l - \text{N}$$

In equilibrium,

Strength of weld = Applied force

$$803.31 l = 109.10 \times 10^3 \text{ N}$$

$$l = \frac{109.10 \times 10^3}{803.31} = 135.81 \text{ mm} \quad \text{Say } 140 \text{ mm}$$

**Note:**

If  $b < 16t$ , only longitudinal weld can be provided

If  $b > 16t$ , along with longitudinal weld End weld should also be provided.

$$b = 60 \text{ mm}, 16 \times t = 16 \times 8 = 128 \text{ mm}$$

Since  $b < 16 \times t$ , Only longitudinal weld can be provided.

$$\text{Length of longitudinal weld on each side} = \frac{140}{2} = 70 \text{ mm}$$



**Length of longitudinal weld required:** It is the maximum of the following

1. Overlap length a)  $4 \times 8 = 32$  mm b) 40 mm
2. Width of plate (60 mm)
3. Length of longitudinal weld calculated = 70 mm

**The overall length of weld provided with end return of  $(2 \times D) = 2 \times 70 + 2 \times 2 \times 6 = 164$  mm**

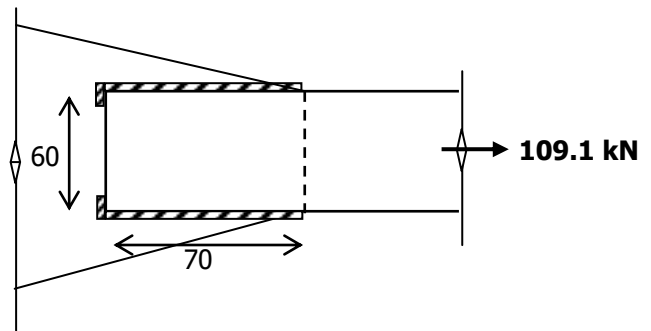

**Problem:**

A tie bar of 120 mm x 10 mm is to be connected to other of size 120 mm x 14 mm. if the tie bars are to be loaded by a pull of 160 KN, Find out the size of end fillets such that the stresses in both the end fillets are same. Take  $f_u=410$  N/ mm<sup>2</sup>, Assume shop welding.

**Solution:**

Both the plates elongate equally under the load and therefore the stress will be equal in both plates. Force carried by both the plates will be different since the cross sectional areas are different.

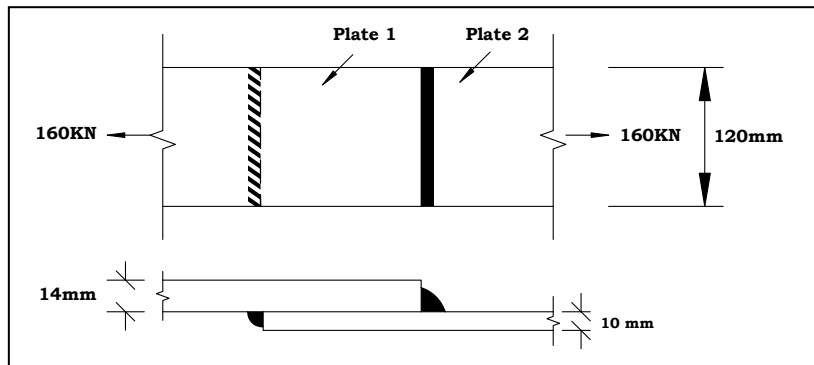

Hence the weld size proportional to thickness of plate is provided.

Let  $D_1$  and  $D_2$  be the size of the weld of Plate (1) and Plate (2)

$$\frac{D_1}{D_2} = \frac{14}{10}$$

$$D_1 = 1.4D_2$$

Length of weld in each case = 120 mm

Strength of weld in plate (1) =

$$0.707 \times D_1 \times b \times \frac{f_u}{\sqrt{3} \times \gamma_{mw}} = 0.707 \times 1.4D_2 \times 120 \times \frac{410}{\sqrt{3} \times 1.25}$$

Strength of weld in plate (1) = 22492.72 $D_2$  N

Strength of weld in plate (2) =

$$0.707D_2 \times b \times \frac{f_u}{\sqrt{3} \times \gamma_{mw}} = 0.707 \times D_2 \times 120 \times \frac{410}{\sqrt{3} \times 1.25}$$

Strength of weld in plate (2) = 16066.23 $D_2$  N

Load carried by tie bar = 160 KN

Since there are two sizes of weld,

$$\text{Total strength of weld} = 22492.72D_2 + 16066.23D_2 = 160 \times 10^3 \text{ N}$$



$$D_2 = \frac{160 \times 10^3}{(22492.72 + 16066.23)} = 4.15 \text{ mm} \quad \text{Say } 5 \text{ mm} < 10 - 1.5 = 8.5 \text{ mm} \quad \text{Safe}$$

$$D_1 = 1.4 \times D_2 = 1.4 \times 5 = 7 \text{ mm} \quad 7 \text{ mm} \leq 14 - 1.5 = 12.5 \text{ mm} \quad \text{Safe}$$

**Overlap length:** Max of the following

- a)  $4 \times t = 4 \times 8 = 32 \text{ mm}$ , b)  $40 \text{ mm}$ .

**Provide 7 mm size weld for plate (1) and 5 mm size weld for plate (2).**

**Problem:**

Find the sizes of the weld for two plates of size 100 mm x 8 mm and 100 mm x 12 mm. The ultimate stress in weld is 410 MPa. Assume field welding.

**Solution:**

Both the plates elongate equally under the load and therefore the stress will be equal in both plates. Force carried by both the plates will be different since the cross sectional areas are different.

Hence the weld size proportional to thickness of plate is provided.

Let  $D_1$  and  $D_2$  be the size of the weld of Plate (1) and Plate (2)

$$\frac{D_1}{D_2} = \frac{8}{12}$$

$$D_1 = 0.67D_2$$

**Cl: 6.2, P- 32**

We know that,

$$\text{Force} = \text{Stress} \times \text{Area} = T_{dg} = \frac{A_g f_y}{\gamma_{mo}}$$

$A_g$  = Width of plate x Thickness of plate

$$\text{Strength of plate (1)} = \text{Stress} \times \text{area} = b \times t_1 \times \frac{f_y}{\gamma_{mo}} = \frac{100 \times 8 \times 250}{1.1 \times 1000} = 181.82 \text{ KN}$$

$$\text{Strength of plate (2)} = \text{Stress} \times \text{area} = b \times t_2 \times \frac{f_y}{\gamma_{mo}} = \frac{100 \times 12 \times 250}{1.1 \times 1000} = 272.73 \text{ KN}$$

Strength of joint = Full strength of thinner plate = 181.82 KN

Since there are two sizes of weld,

Total strength of weld

$$= 0.707D_1 \times b \times \frac{f_u}{\sqrt{3} \times \gamma_{mw}} + 0.707D_2 \times b \times \frac{f_u}{\sqrt{3} \times \gamma_{mw}} = 181.82 \times 10^3 \text{ N}$$

$$0.707 \times 0.67D_2 \times 100 \times \frac{410}{\sqrt{3} \times 1.5} + 0.707 \times D_2 \times 100 \times \frac{410}{\sqrt{3} \times 1.5} = 181.82 \times 10^3$$

$$7475.26D_2 + 11157.10D_2 = 181.82 \times 10^3$$

$$D_2 = \frac{181.82 \times 10^3}{(7475.26 + 11157.10)} = 9.76 \text{ mm} < \text{Max size} = t - 1.5 = 12 - 1.5 = 10.5 \text{ mm} \quad \text{Safe}$$





$$D_1 = 0.67 \times D_2 = 0.67 \times 9.76 = 6.5 \text{ mm} \leq \text{Max size} = t - 1.5 = 8 - 1.5 = 6.5 \text{ mm} \quad \text{Safe}$$

**Overlap length:** Max of the following

b)  $4 \times t = 4 \times 8 = 32 \text{ mm}$ ,    b)  $40 \text{ mm}$ .

**Provide 6.5 mm size weld for plate (1) and 9.76 mm size weld for plate (2)**

**Problem:**

Two plates 160 mm x 10 mm and 180 mm x 8 mm are to be connected by a lap joint using 8 mm size weld. Assuming field welding. Assume Fe 410 steel. Design the joint.

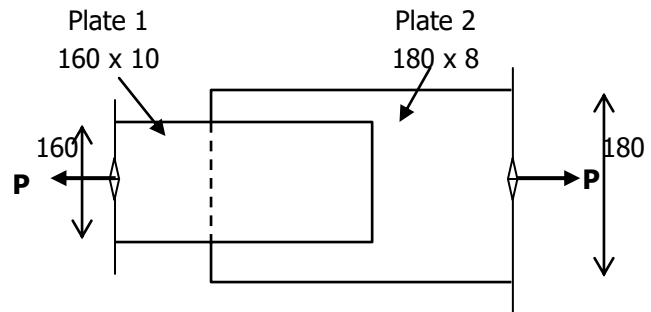

**Solution:**

**Cl: 6.2, P- 32**

Tension capacity of the member (1)/Strength of plate (1) =

$$T_{dg} = \frac{A_g f_y}{\gamma_{mo}} = \frac{b \times t_1 \times f_y}{\gamma_{mo}} = \frac{160 \times 10 \times 250}{1.1 \times 1000} = 363.64 \text{ KN}$$

Tension capacity of the member (2)/Strength of plate (2) =

$$T_{dg} = \frac{A_g f_y}{\gamma_{mo}} = \frac{b \times t_2 \times f_y}{\gamma_{mo}} = \frac{180 \times 8 \times 250}{1.1 \times 1000} = 327.30 \text{ KN}$$

Strength of joint = Full strength of thinner plate = 327.30 KN

Fillet weld is done for the plate (1) of size 160 mm x 10 mm.

Size of weld = 8 mm (given)

Strength of weld =

$$0.707 \times D \times l \frac{f_u}{\sqrt{3} \times \gamma_{mw}} = 0.707 \times 8 \times \frac{410}{\sqrt{3} \times 1.50} = 892.60 \text{ N}$$

$$\text{Total length of weld} = l = \frac{327.30 \times 1000}{892.60} = 366.65 \text{ mm}$$

$b = 160 \text{ mm}$ ,  $16 \times t = 16 \times 8 = 128 \text{ mm}$ , since  $b > 16 \times t$ , End fillet weld of length 160 mm has to be provided along with longitudinal side fillet weld.

$$\text{Length of longitudinal weld on each side} = \frac{366.65 - 160}{2} = 103.32 \text{ mm}$$

Say 105 mm.

**Length of longitudinal weld required:**

It is the maximum of the following

1. Overlap length a)  $4 \times 8 = 32 \text{ mm}$   
b)  $40 \text{ mm}$
2. Length of longitudinal weld calculated = 105 mm.

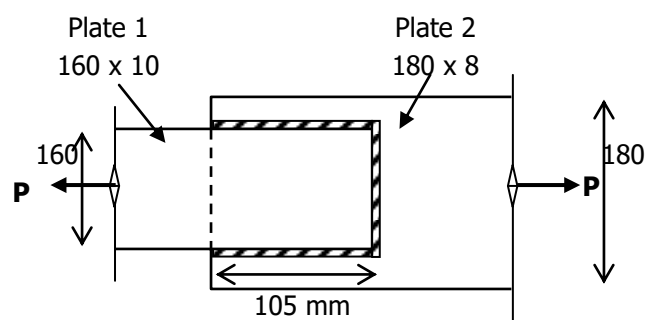



**Provide 8 mm fillet weld for a longitudinal length of 105 mm and a transverse length of 160 mm length.**

**Problem:®**

Design the fillet welded joint between two plates of size 180 mm x 8 mm and 200 mm x 8 mm to develop the full strength of the smaller plate in tension. Assuming field welding.

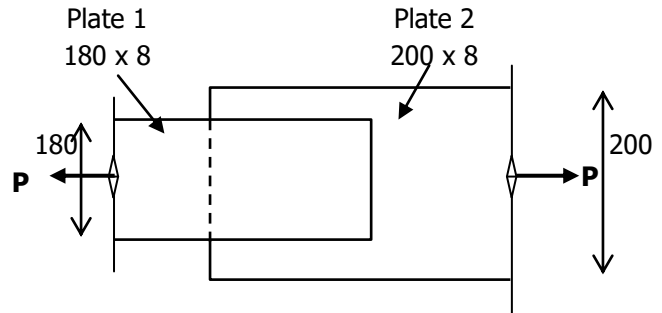

**Solution: Cl: 6.2, P- 32**

Tension capacity of the member

(1)/Strength of 180 x 8 mm plate  

$$= T_{dg} = \frac{A_g f_y}{\gamma_{mo}} = \frac{b \times t_1 \times f_y}{\gamma_{mo}} = \frac{180 \times 8 \times 250}{1.1 \times 1000} = 327.27 \text{ KN}$$

Tension capacity of the member (2)/Strength of 200 x 8 mm plate

$$= T_{dg} = \frac{A_g f_y}{\gamma_{mo}} = \frac{b \times t_2 \times f_y}{\gamma_{mo}} = \frac{200 \times 8 \times 250}{1.1 \times 1000} = 363.64 \text{ KN}$$

Strength of joint = Full strength of thinner plate = 327.27 KN

Maximum size of weld = 8 – 1.5 = 6.5 mm Say 6 mm.

Strength of weld =

$$0.707D \times l \times \frac{f_u}{\sqrt{3} \times \gamma_{mw}} = 0.707 \times 6 \times l \times \frac{410}{\sqrt{3} \times 1.50} = 669.43 \text{ l} - \text{N}$$

Total length of weld =  $l = \frac{327.27 \times 1000}{669.43} = 488.88 \text{ mm}$

b = 180 mm, 16 x t = 16 x 8 = 128 mm, since b > 16 x t, End fillet weld of length 180 mm has to be provided along with longitudinal side fillet weld.

Length of longitudinal weld on each side =  $\frac{488.88 - 180}{2} = 154.44 \text{ mm}$

Say 155 mm.

**Length of longitudinal weld required:**

It is the maximum of the following

1. Overlap length a) 4 x 8 = 32 mm  
b) 40 mm
2. Length of longitudinal weld calculated = 155 mm.

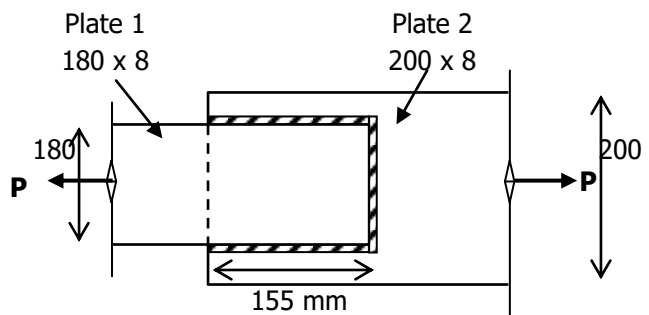

**Provide 6 mm fillet weld for a longitudinal length of 155 mm and a transverse length of 180 mm length.**

**Problem: ®**

A tie member of a truss consisting of an angle section ISA 90 x 90 x 6 of Fe 410 grade is welded to an 8 mm gusset plate. Design a weld to transmit a load equal to the full strength of the member. Assume shop welding.

**Solution:**

Properties of ISA90 x 90 x 6

$$A = 10.47 \text{ cm}^2 = 1047 \text{ mm}^2 = A_g$$

$$C_{zz} = 2.42 \text{ cm} = 24.2 \text{ mm}, e_{zz} = 65.8 \text{ mm}$$

**Cl: 6.2, P- 32**

Tension capacity of the member =  $T_{dg}$

$$T_{dg} = \frac{A_g f_y}{\gamma_{mo}} \frac{1047 \times 250}{1.1} = 237.95 \times 10^3 \text{ N} = 237.95 \text{ kN}$$

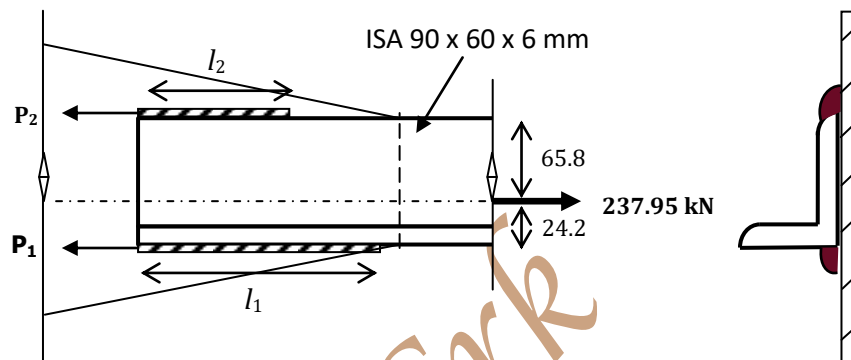

$$\text{Size of weld} \neq \frac{3}{4} \times 6 = 4.5 \text{ mm} \quad \text{say } 4 \text{ mm} > 3 \text{ mm}$$

$$f_u = 410 \text{ N/mm}^2.$$

Let  $P_1$  and  $P_2$  be the strength of weld at bottom and top edge resp.

$$\begin{aligned} \text{Strength of weld at bottom } (P_1) &= 0.707 \times D \times l_1 \times \frac{f_u}{\sqrt{3} \times \gamma_{mw}} \\ &= 0.707 \times 4 \times l_1 \times \frac{410}{\sqrt{3} \times 1.25} = 535.54 l_1 - \text{N} \end{aligned}$$

$$\begin{aligned} \text{Strength of weld at top } (P_2) &= 0.707 \times D \times l_2 \times \frac{f_u}{\sqrt{3} \times \gamma_{mw}} \\ &= 0.707 \times 4 \times l_2 \times \frac{410}{\sqrt{3} \times 1.25} = 535.54 l_2 - \text{N} \end{aligned}$$

$$P_1 + P_2 = P$$

Distributing weld in such a way that c.g of the weld coincides with that of the angle section.

Taking moment of force 'P' and bottom weld  $P_1$  about top edge.

$$P_1 \times 90 = P \times 65.8$$

$$535.54 \times l_1 \times 90 = 237.95 \times 65.8$$

$$l_1 = \frac{237.95 \times 65.8}{535.54 \times 90} = 324.85 \text{ mm} \quad \text{Say } 325 \text{ mm}$$



$$P_1 = 535.54 \times 325 = 174.05 \times 10^3 \text{ N}$$

$$P_2 = P - P_1 = 237.95 \times 10^3 - 174.05 \times 10^3 = 63.9 \times 10^3 \text{ N}$$

$$l_2 = \frac{63.9 \times 10^3}{535.54 \times 90} = 119.31 \text{ mm} \quad \text{Say } 120 \text{ mm}$$

**Effective length of  $l_1 = 325 + 2 \times 4 = 333 \text{ mm}$  say  $335 \text{ mm}$**

**Effective length of  $l_2 = 120 + 2 \times 4 = 128 \text{ mm}$  say  $130 \text{ mm}$**

**Problem: ②**

Calculate the pull on a single angle 90 x 60 x 6 mm member connected to a gusset plate by fillet weld as shown in the fig. Also determine the length of the weld ( $l_1+l_2+l_3$ ) to carry the load. Assume shop welding.

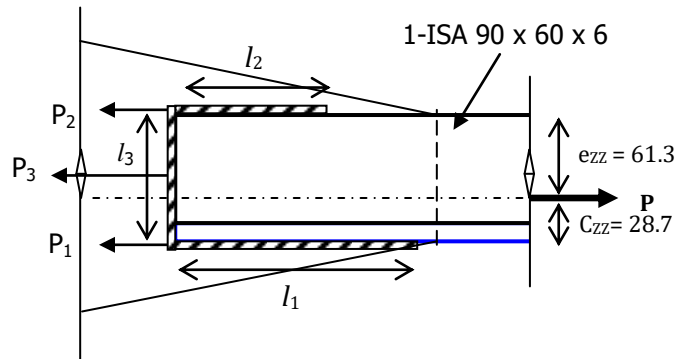

**Solution:**

Properties of 1-ISA 90 x 60 x 6

$$\text{Area} = 8.8 \text{ cm}^2 = 880 \text{ mm}^2$$

$$C_{zz} = 2.42 \text{ cm} = 28.7 \text{ mm}, e_{zz} = 61.3 \text{ mm}$$

**Cl: 6.2, P- 32**

$$\text{Tension capacity of the member} = T_{dg} = \frac{A_g f_y}{\gamma_{mo}} = \frac{880 \times 250}{1.1} = 200 \times 10^3 \text{ N} = 200 \text{ KN}$$

Size of weld: Min size = 3mm,

$$\text{Max Size } \not\prec = \frac{3}{4} \times 6 = 4.5 \text{ mm} \quad \text{say } 4 \text{ mm}$$

Let  $P_1$  ,  $P_2$  and  $P_3$  be the strength of welds at bottom edge, top edge and End resp.

$$\begin{aligned} \text{Strength of weld at bottom } (P_1) &= 0.707 \times D \times l_1 \times \frac{f_u}{\sqrt{3} \times \gamma_{mw}} \\ &= 0.707 \times 4 \times l_1 \times \frac{410}{\sqrt{3} \times 1.25} = 535.54 l_1 - \text{N} \end{aligned}$$

$$\text{Strength of weld at top } (P_2) = 535.54 l_2 - \text{N}$$

$$\begin{aligned} \text{Strength of End weld } (P_3) &= 0.707 \times D \times l_3 \times \frac{f_u}{\sqrt{3} \times \gamma_{mw}} \\ &= 0.707 \times 4 \times 90 \times \frac{410}{\sqrt{3} \times 1.25} = 48198.6 - \text{N} = 48.20 \times 10^3 \text{ N} \end{aligned}$$

$$P_1 + P_2 + P_3 = P$$

Distributing weld in such a way that c.g of the welds coincides with that of the angle section.

Taking moment of force 'P', bottom weld  $P_1$  and End weld  $P_3$  about top edge.

$$P_2 \times 90 + P_3 \left( \frac{90}{2} \right) = P \times 61.3$$

$$535.54 \times l_1 \times 90 + 48.20 \times 10^3 \times \frac{90}{2} = 200 \times 10^3 \times 61.3$$



$$l_1 = \frac{200 \times 10^3 \times 61.3 - 48.20 \times 10^3 \times 45}{535.54 \times 90} = 209.36 \text{ mm} \quad \text{Say } 210 \text{ mm}$$

$$P_1 = 535.54 \times 210 = 112.46 \times 10^3 \text{ N}$$

$$P_2 = P - P_1 - P_3 = 200 \times 10^3 - 112.46 \times 10^3 - 48.20 \times 10^3 = 39.34 \times 10^3 \text{ N}$$

$$P_2 = 535.54 \times l_2 = 39.34 \times 10^3$$

$$l_2 = \frac{39.34 \times 10^3}{535.54} = 73.46 \text{ mm} \quad \text{Say } 80 \text{ mm}$$

### Problem: ®

An ISA 150 x 115 mm x 8 mm angle carrying a tensile load of 200 kN is to be connected to a gusset plate by 6 mm fillet welds at the end with its **longer leg**. Design the joint assuming field welding.

### Solution:

Pull = 200 kN, Size of weld = 6 mm, Taking,  $f_u = 410 \text{ N/mm}^2$ .

$C_{zz} = 4.46 \text{ cm} = 44.6 \text{ mm}$ ,  $e_{zz} = 105.4 \text{ mm}$ ,

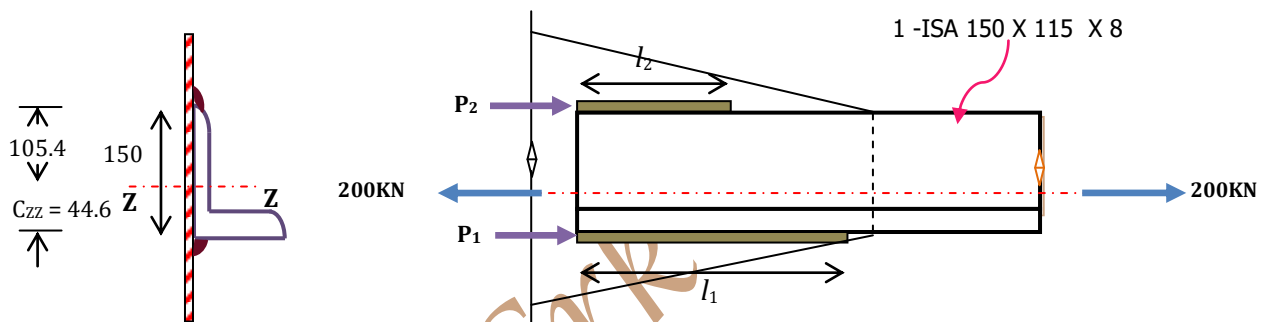

$$\begin{aligned} \text{Strength of weld at bottom}(P_1) &= 0.707 \times D \times l_1 \times \frac{f_u}{\sqrt{3} \times \gamma_{mw}} \\ &= 0.707 \times 6 \times l_1 \times \frac{410}{\sqrt{3} \times 1.50} = 670 l_1 \text{ N} \end{aligned}$$

$$\text{Strength of weld at top}(P_2) = 670 l_2 \text{ N}$$

$$P_1 + P_2 = P$$

Distributing weld in such a way that c.g of the weld coincides with that of the angle section.

Taking moment of force 'P' and bottom weld  $P_1$  about top edge.

$$P_1 \times 150 = P \times 105.4$$

$$670 \times l_1 \times 150 = 200 \times 10^3 \times 105.4$$

$$l_1 = \frac{200 \times 10^3 \times 105.4}{670 \times 150} = 209.75 \text{ mm} \quad \text{Say } 210 \text{ mm}$$

$$P_1 = 670 \times 210 = 140.7 \times 10^3 \text{ N}$$

$$P_2 = P - P_1 = 200 \times 10^3 - 140.7 \times 10^3 = 59.3 \times 10^3 \text{ N}$$

$$P_2 = 670 l_2 = 59.3 \times 10^3 \text{ N}$$

$$\therefore l_2 = \frac{59.3 \times 10^3}{670} = 88.5 \text{ mm} \quad \text{Say } 90 \text{ mm}$$

### Problem:®



The 150 x 115 mm x 8 mm angle carrying a tensile load of 200 KN is to be connected to a gusset plate by 6 mm fillet welds at the ends with its **shorter leg**. Design the joint assuming field welding.

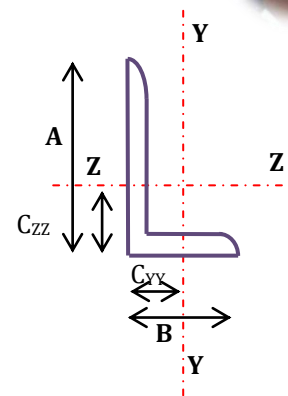

**Solution:**

Pull = 200 KN, Size of weld = 6 mm, Taking,  $f_u = 410 \text{ N/mm}^2$ .

$$C_{zz} = 4.46 \text{ cm} = 44.6 \text{ mm}$$

$$C_{yy} = 2.73 \text{ cm} = 27.3 \text{ mm}$$

**Note:** In this case short leg is connected to the gusset plate, therefore,  $C_{yy}$  becomes  $C_{zz}$  after tilting and connecting to gusset plate.

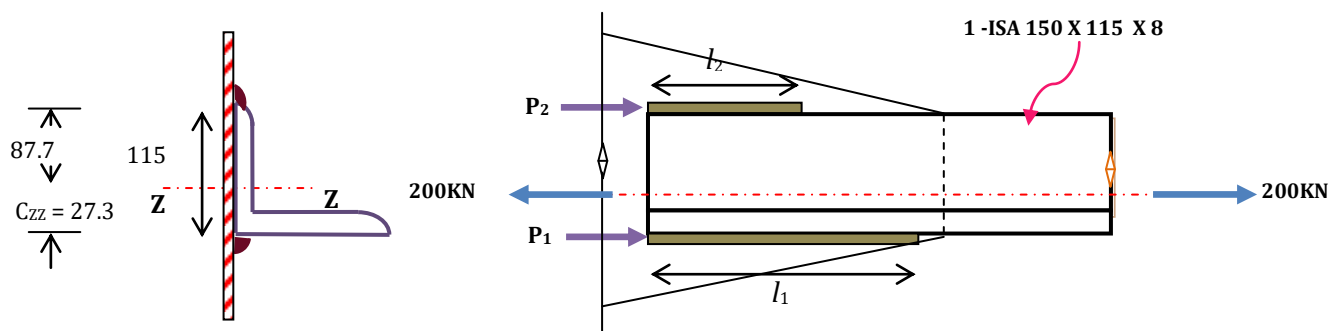

$$\begin{aligned} \text{Strength of weld at bottom}(P_1) &= 0.707 \times D \times l_1 \times \frac{f_u}{\sqrt{3} \times \gamma_{mw}} \\ &= 0.707 \times 6 \times l_1 \times \frac{410}{\sqrt{3} \times 1.50} = 670 l_1 \text{ N} \end{aligned}$$

$$\text{Strength of weld at top}(P_2) = 670 l_2 \text{ N}$$

$$P_1 + P_2 = P$$

Distributing weld in such a way that c.g of the weld coincides with that of the angle section.

Taking moment of force 'P' and bottom weld  $P_1$  about top edge.

$$P_2 \times 115 = P \times 87.7$$

$$670 \times l_1 \times 115 = 200 \times 10^3 \times 87.7$$

$$l_1 = \frac{200 \times 10^3 \times 87.7}{670 \times 115} = 227.85 \text{ mm} \quad \text{Say } 230 \text{ mm}$$

$$P_1 = 670 \times 230 = 153.97 \times 10^3 \text{ N}$$

$$P_2 = P - P_1 = 200 \times 10^3 - 153.97 \times 10^3 = 46.03 \times 10^3 \text{ N}$$

$$P_2 = 670 l_2 = 46.03 \times 10^3 \text{ N}$$

$$\therefore l_2 = \frac{46.03 \times 10^3}{670} = 68.75 \text{ mm} \quad \text{Say } 70 \text{ mm}$$

**Problem:®**

A tie member of a roof truss consists of 2-ISA 125 x 75 x 10 mm is subjected to a pull of 250 KN. The angles are connected **on either side of a gusset plate** of 10 mm thick with **long legs back to back**. Design the weld.

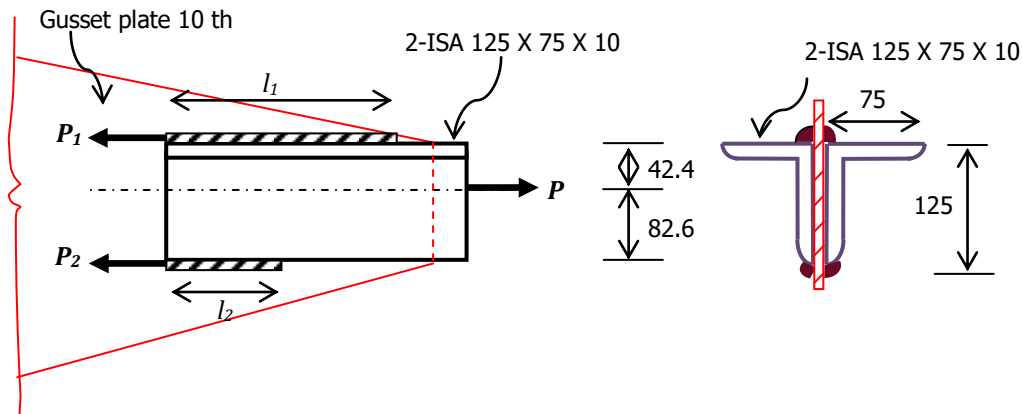
**Solution:**

Let  $P_1$  and  $P_2$  be the strength of welds at top and bottom edges resp.

Max size of weld =  $\frac{3}{4} \times 10 = 7.5$  mm Say 6 mm

Fillet weld of 6 mm size is provided on both sides of gusset plate.

Taking  $f_u = 410$  N/mm<sup>2</sup> and site welding  $\gamma_{mw} = 1.5$ .

$$\begin{aligned} \text{Strength of weld at top } (P_1) &= 0.707 \times D \times l_1 \times \frac{f_u}{\sqrt{3} \times \gamma_{mw}} \\ &= 0.707 \times 6 \times l_1 \times \frac{410}{\sqrt{3} \times 1.50} = 670 l_1 \text{ N} \end{aligned}$$

$$\text{Strength of weld at bottom } (P_2) = 0.707 \times D \times l_2 \times \frac{f_u}{\sqrt{3} \times \gamma_{mw}} = 670 l_2 \text{ N}$$

Welding calculation is done for single angle section and the same is provided for the two section on either side

$$P_1 + P_2 = P'$$

$$\text{Load carried by single angle section } (P') = \frac{250}{2} = 125 \text{ KN}$$

Distributing weld in such a way that c.g of the weld coincides with that of the angle section.

Taking moment of force 'P' and bottom weld  $P_2$  about top edge.

$$P_2 \times 125 = P' \times 42.4$$

$$670 \times l_2 \times 125 = 125 \times 10^3 \times 42.4$$

$$l_2 = \frac{125 \times 10^3 \times 42.4}{670 \times 125} = 63.30 \text{ mm} \quad \text{Say } 70 \text{ mm}$$

$$P_2 = 670 \times 70 = 46.9 \times 10^3 \text{ N}$$

$$P_1 = P - P_2 = 125 \times 10^3 - 46.9 \times 10^3 = 78.1 \times 10^3 \text{ N}$$

$$P_1 = 670 l_1 = 78.1 \times 10^3 \text{ N}$$

$$\therefore l_1 = \frac{78.1 \times 10^3}{670} = 116.57 \text{ mm} \quad \text{Say } 120 \text{ mm}$$



**Problem:®**

A tie member of a roof truss consists of 2-ISA 125 x 75 x 10 mm is subjected to a pull of 250 KN. The angles are connected **on either side of a gusset plate** of 10 mm thick with **short legs back to back**. Design the weld.

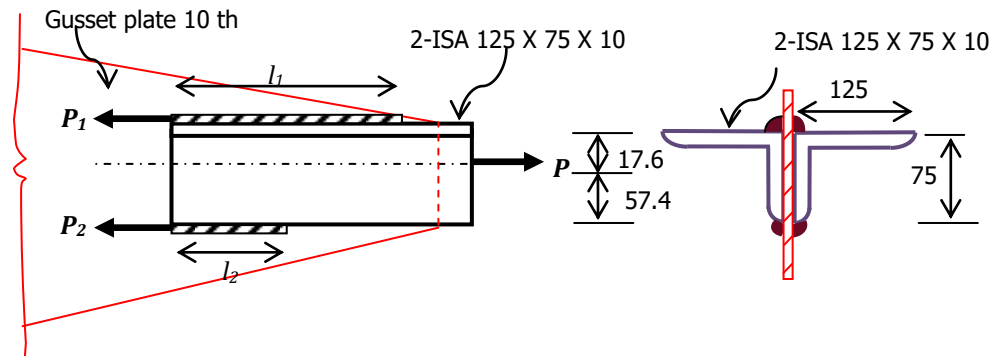
**Solution:**

Let  $P_1$  and  $P_2$  be the strength of welds at top and bottom edges resp.

Max size of weld =  $\frac{3}{4} \times 10 = 7.5$  mm Say 6 mm

Fillet weld of 6 mm size is provided on both sides of gusset plate.

Taking  $f_u = 410$  N/mm<sup>2</sup> and site welding  $\gamma_{mw} = 1.5$ .

$$\begin{aligned} \text{Strength of weld at top } (P_1) &= 0.707 \times D \times l_1 \times \frac{f_u}{\sqrt{3} \times \gamma_{mw}} \\ &= 0.707 \times 6 \times l_1 \times \frac{410}{\sqrt{3} \times 1.50} = 670 l_1 \text{ N} \end{aligned}$$

$$\text{Strength of weld at bottom } (P_2) = 0.707 \times D \times l_2 \times \frac{f_u}{\sqrt{3} \times \gamma_{mw}} = 670 l_2 \text{ N}$$

Welding calculation is done for single angle section and the same is provided for the two section on either side

$$P_1 + P_2 = P'$$

$$\text{Load carried by single angle section } (P') = \frac{250}{2} = 125 \text{ KN}$$

Distributing weld in such a way that c.g of the weld coincides with that of the angle section.

Taking moment of force 'P' and bottom weld  $P_2$  about top edge.

$$P_2 \times 75 = P' \times 17.6$$

$$670 \times l_2 \times 75 = 125 \times 10^3 \times 17.6$$

$$l_2 = \frac{125 \times 10^3 \times 17.6}{670 \times 75} = 43.78 \text{ mm} \quad \text{Say } 50 \text{ mm}$$

$$P_2 = 670 \times 50 = 33.5 \times 10^3 \text{ N}$$

$$P_1 = P - P_2 = 125 \times 10^3 - 33.5 \times 10^3 = 91.5 \times 10^3 \text{ N}$$

$$P_1 = 670 l_1 = 91.5 \times 10^3 \text{ N}$$

$$\therefore l_1 = \frac{91.5 \times 10^3}{670} = 136.57 \text{ mm} \quad \text{Say } 140 \text{ mm}$$

**Problem:**

A tie member of a roof truss consists of 2-ISA 125 x 75 x 10 mm is subjected to a pull of 250 kN. The angles are connected on same side of a gusset plate of 10 mm thick with long legs back to back. Design the weld.

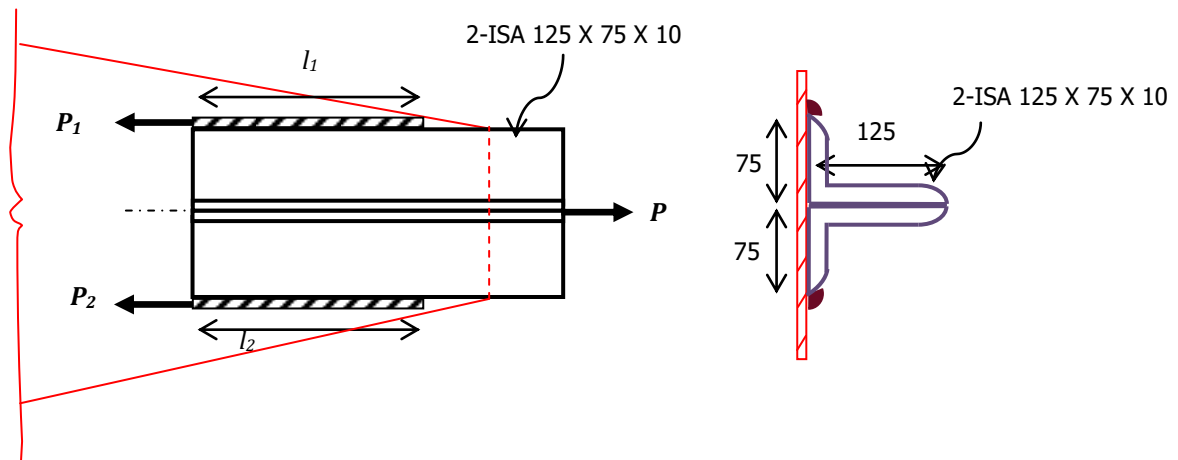
**Solution:**

Let  $P_1$  and  $P_2$  be the strength of welds at top and bottom edges resp.

Max size of weld =  $\frac{3}{4} \times 10 = 7.5$  mm Say 6 mm

Taking  $f_u = 410$  N/mm<sup>2</sup> and site welding  $\gamma_{mw} = 1.5$ .

$$\begin{aligned} \text{Strength of weld at top } (P_1) &= 0.707 \times D \times l_1 \times \frac{f_u}{\sqrt{3} \times \gamma_{mw}} \\ &= 0.707 \times 6 \times l_1 \times \frac{410}{\sqrt{3} \times 1.50} = 670 l_1 \text{ N} \end{aligned}$$

$$\text{Strength of weld at bottom } (P_2) = 0.707 \times D \times l_2 \times \frac{f_u}{\sqrt{3} \times \gamma_{mw}} = 670 l_2 \text{ N}$$

$$P_1 + P_2 = P = 250 \text{ kN}$$

Distributing weld in such a way that c.g of the weld coincides with that of the angle section.

Taking moment of force 'P' and bottom weld  $P_2$  about top edge.

$$P_2 \times 150 = P \times 75$$

$$670 \times l_2 \times 150 = 250 \times 10^3 \times 75$$

$$l_2 = \frac{250 \times 10^3 \times 75}{670 \times 150} = 186.57 \text{ mm} \quad \text{Say } 190 \text{ mm}$$

$$P_2 = 670 \times 190 = 127.3 \times 10^3 \text{ N}$$

$$P_1 = P - P_2 = 250 \times 10^3 - 127.3 \times 10^3 = 122.7 \times 10^3 \text{ N}$$

$$P_1 = 670 l_1 = 122.7 \times 10^3 \text{ N}$$

$$\therefore l_1 = \frac{122.7 \times 10^3}{670} = 183.13 \text{ mm} \quad \text{Say } 190 \text{ mm}$$

**Problem:®**

A tie member of a roof truss consists of 2-ISA 125 x 75 x 10 mm. the tie member is subjected to pull of 250 kN. The angles are connected on same side of a gusset plate of 10 mm thick with short legs back to back. Design the weld.

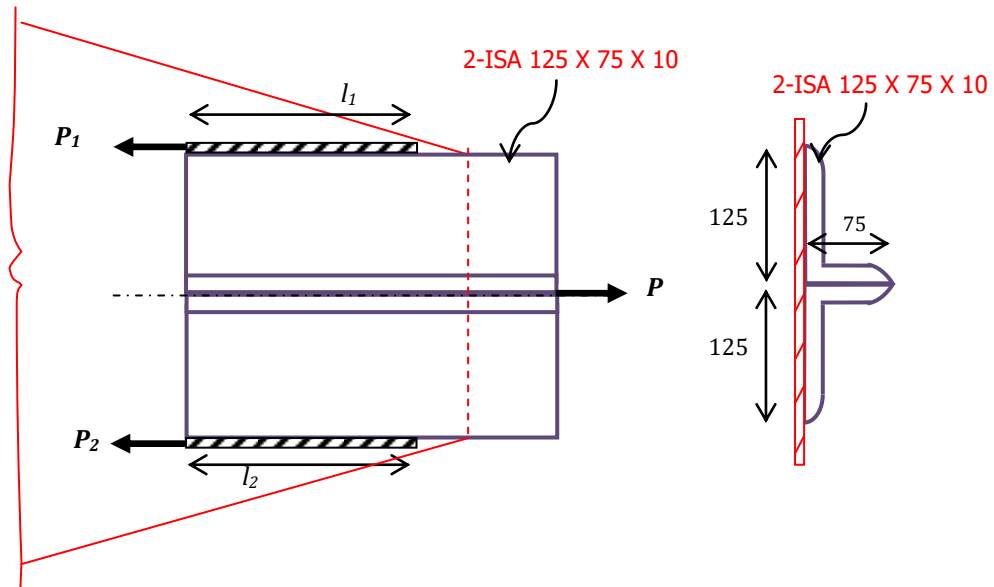
**Solution:**

Let  $P_1$  and  $P_2$  be the strength of welds at top and bottom edges resp.

Max size of weld =  $\frac{3}{4} \times 10 = 7.5$  mm Say 6 mm

Taking  $f_u = 410$  N/mm<sup>2</sup> and site welding  $\gamma_{mw} = 1.5$ .

$$\begin{aligned} \text{Strength of weld at top } (P_1) &= 0.707 \times D \times l_1 \times \frac{f_u}{\sqrt{3} \times \gamma_{mw}} \\ &= 0.707 \times 6 \times l_1 \times \frac{410}{\sqrt{3} \times 1.50} = 670 l_1 \text{ N} \end{aligned}$$

$$\text{Strength of weld at bottom } (P_2) = 0.707 \times D \times l_2 \times \frac{f_u}{\sqrt{3} \times \gamma_{mw}} = 670 l_2 \text{ N}$$

$$P_1 + P_2 = P = 250 \text{ kN}$$

Distributing weld in such a way that c.g of the weld coincides with that of the angle section.

Taking moment of force 'P' and bottom weld  $P_2$  about top edge.

$$P_2 \times 250 = P \times 125$$

$$670 \times l_2 \times 250 = 250 \times 10^3 \times 125$$

$$l_2 = \frac{250 \times 10^3 \times 125}{670 \times 250} = 186.57 \text{ mm} \quad \text{Say } 190 \text{ mm}$$

$$P_2 = 670 \times 190 = 127.3 \times 10^3 \text{ N}$$

$$P_1 = P - P_2 = 250 \times 10^3 - 127.3 \times 10^3 = 122.7 \times 10^3 \text{ N}$$

$$P_1 = 670 l_1 = 122.7 \times 10^3 \text{ N}$$

$$\therefore l_1 = \frac{122.7 \times 10^3}{670} = 183.13 \text{ mm} \quad \text{Say } 190 \text{ mm}$$



---

**Problem:**

A tie member of a roof truss consists of 2-ISA 90 x 90 x 8 mm. The tie member is subjected to pull of 250 KN. The angles are connected **on either side of a gusset plate** of 10 mm thick. Design the weld.

**Problem:**

A tie member of a roof truss consists of 2-ISA 90 x 90 x 8 mm. The tie member is subjected to pull of 250 KN. The angles are connected **on same side of a gusset plate** of 10 mm thick. Design the weld.

Grk